

Importa y distribuye en Argentina:



GL20-2S485/GL20-2S485-MDB Communication Module Equipment Guide



Industrial
Automation



New Energy
Vehicle



Intelligent
Elevator



Intelligent
Robot



Digital
Energy



Rail
Transit



Data code PS00021937A01

Legal Information

Copyright

Copyright © 2025 Shenzhen Inovance Technology Co., Ltd. All rights reserved.

This documentation is the exclusive property of Shenzhen Inovance Technology Co., Ltd. No individual or entity may excerpt, reproduce, modify, translate, or distribute any content herein without written consent from Inovance.

Legal action will be taken against infringement.

Trademarks

INOVANCE is a registered trademark of Shenzhen Inovance Technology Co., Ltd. and its affiliates. All other trademarks or registered trademarks mentioned in this documentation are the property of their respective owners. Unauthorized use of these trademarks by third parties for any purpose without written authorization could violate the rights of their owners.

Disclaimer of Liability

Due to continuous updates and improvements of products and technologies, the content of this documentation may not fully match the actual products. In the event of any discrepancies, the actual products shall prevail.

The contents are subject to change without notice due to product upgrade.

Waste Disposal

The storage, use, and disposal of this product (including optional accessories) must comply with local laws and regulations.

Qualified Personnel

The product/system described in this documentation may be operated only by personnel qualified for the specific task in accordance with the relevant documentation, in particular its warning notices and safety instructions. Qualified personnel can identify the risks of the product/system and prevent possible dangers.

Proper Use of the Product

Proper transportation, storage, assembly, installation, commissioning, operation, and maintenance are required to ensure the safe operation of the product without any problems. The required ambient conditions must be met. All operations must follow the guidelines provided in this documentation.

Preface

Introduction

This guide describes the product overview, model and nameplate specifications, component descriptions, terminal wiring, as well as technical and environmental specifications of the module.

Target audience

This guide is primarily intended for the following engineers:

- Inovance development/service engineers
- Channel/End-user chief technical engineers
- Channel/End-user mechanical engineers
- Channel/End-user electrical engineers
- Channel/End-user software engineers
- Channel/End-user maintenance/service engineers

Documentation guide

The product documentation package consists of an equipment guide and a system guide, enabling users to quickly access the information they need.

- Equipment guide: Provides a brief overview of module attributes, including model descriptions, component descriptions, technical specifications, and terminal wiring diagrams.
- System guide: Covers all typical application scenarios of the system, encompassing system introduction, installation, wiring, configuration and commissioning, troubleshooting, and maintenance.

Standards compliance

The following table lists the certifications, directives, and standards that the product may comply with. For details about the acquired certificates, see the certification marks on the product nameplate.

Certification	Directive		Standards compliance
CE certification	EMC directive	2014/30/EU	24 VDC products: EN 61131-2 220 VAC products: EN 61131-2 EN 61000-3-2 EN 61000-3-3
	LVD directive	2014/35/EU	EN 61010-1 EN 61010-2-201
	RoHS directive	2011/65/EU amended by (EU)2015/863	EN IEC 63000
UL/cUL certification	-		UL 61010-1 UL 61010-2-201 CAN/CSA-C22.2 No. 61010-1 CSA C22.2 NO. 61010-2-201

Certification	Directive		Standards compliance
KCC certification	-		-
EAC certification	-		-
UKCA certification	Safety regulations	Electrical Equipment (Safety) Regulations 2016	EN 61010-1 EN 61010-2-201
	EMC regulations	Electromagnetic Compatibility Regulations 2016	24 VDC products: EN 61131-2 220 VAC products: EN 61131-2 EN 61000-3-2 EN 61000-3-3
	RoHS regulations	Directive (RoHS) Regulations 2012	EN IEC 63000

More documents

Document	Code	Description
GL20 Series Module System Guide	PS00022010	This guide covers all typical application scenarios of the system, providing detailed instructions on system configuration, installation, wiring, commissioning, troubleshooting.
GL20-2S485/GL20-2S485-MDB Communication Module Equipment Guide (This guide)	PS00021937	This guide describes the product overview, model and nameplate specifications, component descriptions, terminal wiring, as well as technical and environmental specifications of the module.

Revision history

Revision date	Version	Description of change(s)
April 2026	A01	Corrected some minor errors.
December 2025	A00	First release

Access to the guide

This guide is not delivered with the product. You can obtain the PDF version in the following ways:

- Visit <https://www.inovance.com/global>, and choose Service> Support > Documentation Download.
- Scan the QR code on the product with your smart phone.
- Scan the QR code below to install My Inovance app, where you can search for and download the guide.



Warranty disclaimer

Inovance provides warranty service within the warranty period (as specified in your order) for any fault or damage that is not caused by improper operation of the user. Maintenance fees will be charged after the warranty period expires.

Within the warranty period, maintenance fee will be charged for the following damage:

- Damage caused by operations not following the instructions in the user guide
- Damage caused by fire, flood, or abnormal voltage
- Damage caused by using the product for unintended functions
- Damage caused by using the product outside the specified scope
- Damage or secondary damage caused by force majeure (natural disaster, earthquake, and lightning strike)

The maintenance fee will be charged according to the latest Price List of Inovance. If otherwise agreed upon, the terms and conditions in the agreement shall prevail.

For details, see Product Warranty Card.

1 Fundamental Safety Instructions

1.1 General Safety Instructions

Safety disclaimer

1. Read through the safety instructions before installing, operating, and servicing the equipment, and comply with these instructions.
2. To ensure personal and equipment safety, observe the notes indicated on the product labels and all the safety instructions in the user guide.
3. The "CAUTION", "WARNING", and "DANGER" are only supplements to the safety instructions.
4. Use this equipment according to the designated environment requirements. Damage caused by improper use is not covered by warranty.
5. Inovance shall take no responsibility for any personal injury or property damage caused by improper use.

Safety levels and definitions



DANGER

The "DANGER" sign indicates that failure to comply with the notice will result in severe personal injuries or even death.



WARNING

The "WARNING" sign indicates that failure to comply with the notice may result in severe personal injuries or even death.



CAUTION

The "CAUTION" sign indicates that failure to comply with the notice may result in minor or moderate personal injury or equipment damage.

Unpacking







WARNING



- Do not install the equipment if you find damage, rust, or signs of use on the equipment or accessories upon unpacking.
- Do not install the equipment if you find water seepage or missing or damaged components upon unpacking.
- Do not install the equipment if you find the packing list does not conform to the equipment you received.



CAUTION

- Check whether the packing is intact and whether there is damage, water seepage, dampness, and deformation before unpacking.
- Unpack the package in accordance with the unpacking sequence. Do not hit the package with force.
- Check whether there is damage, rust, or scratches on the surface of the equipment and equipment accessories upon unpacking.
- Check whether the package contents are consistent with the packing list after unpacking.

Storage and transportation	
 WARNING	<ul style="list-style-type: none"> • Large-scale or heavy equipment must be transported by qualified professionals using specialized hoisting equipment. Failure to comply may result in personal injury or equipment damage. • Before hoisting the equipment, ensure that components such as the front cover and terminal blocks are secured firmly with screws. Loosely-connected components may fall off and result in personal injury or equipment damage. • Never stand or stay below the equipment when the equipment is being hoisted by the hoisting equipment. • When hoisting the equipment with a steel rope, ensure the equipment is hoisted at a constant speed without suffering from vibration or shock. Do not turn the equipment over or let the equipment stay hanging in the air. Failure to comply may result in personal injury or equipment damage.
 CAUTION	<ul style="list-style-type: none"> • Handle the equipment with care during transportation and mind your step to prevent personal injury or equipment damage. • When carrying the equipment with bare hands, hold the equipment casing firmly with care to prevent parts from falling. Failure to comply may result in personal injury. • Store and transport the equipment based on the storage and transportation requirements. Failure to comply can result in equipment damage. • Do not store or transport the drive in environments with water splash, rain, direct sunlight, strong electric field, strong magnetic field, and strong vibration. • Do not store the drive for more than three months. Long-term storage requires stricter protection and necessary inspections. • Pack the drive strictly before transportation. Use a sealed box for long-distance transportation. • Never transport the drive with other device or materials that may harm or have negative impacts on the drive.
Design	
 DANGER	<ul style="list-style-type: none"> • Design a safety circuit and add an error handling program in the software to ensure the product remains in a safe state upon external power failure or product faults. • Add an external fuse or circuit breaker because the module may smoke or catch fire due to long-time overcurrent caused by operation above rated current or load short-circuit.
 WARNING	<ul style="list-style-type: none"> • When the output units such as relays or transistors in this product are damaged, the output may become uncontrollable and remain continuously ON or OFF. • The product design must comply with the overvoltage category requirements specified in the environmental specifications. The power supply must have a system-level lightning protection device, assuring that overvoltage due to lightning shock cannot be applied to the power supply input terminals, signal input terminals, or output terminals, preventing equipment damage. • Make sure that measures have been taken to avoid malfunction caused by the communication faults between the product and related equipment, preventing personal injury or equipment damage.
 CAUTION	<p>Do not create, on the touch screen of the HMI, switches that may result in personal injury of the operator or equipment damage . Use independent switches for performing critical operations. Failure to comply may result in accidents caused by wrong outputs or faults.</p>

Installation	
 DANGER	<p>The equipment must be operated only by professionals with electrical knowledge. Non-professionals are not allowed.</p>
 WARNING	<ul style="list-style-type: none">• Read through the guide and safety instructions before installation.• Do not install this equipment in places with strong electric or magnetic fields.• Before installation, ensure that the mechanical strength of the installation site can bear the weight of the equipment. Failure to comply will result in mechanical hazards.• Before installation, ensure that the installation environment meets the specifications. Failure to comply will result in product damage.• Do not wear loose clothes or accessories during installation. Failure to comply may result in electric shock.• When installing the equipment in a closed environment (such as a cabinet or casing), use a cooling device (such as a fan or air conditioner) to cool the environment down to the required temperature. Failure to comply may result in equipment over-temperature or a fire.• Do not retrofit this product.• Never loosen the fixing bolts on components and modules, or any bolts marked in red.• The equipment shall be installed in a cabinet or terminal device. Protection measures such as a fireproofing shell, electric protection shell, or mechanical protection shell must be provided for the cabinet or terminal device. The IP level must meet IEC standards and local laws and regulations.• Before installing devices with strong electromagnetic interference, such as a transformer, install a shielding device for the equipment to prevent malfunction.• Install the equipment onto an incombustible object such as a metal. Keep the equipment away from combustible objects. Failure to comply will result in a fire.• For products not supporting hot swapping, disconnect all external power supplies of the system before installing/removing the product. Failure to comply may result in electric shock, module fault, or malfunction.
 CAUTION	<ul style="list-style-type: none">• Cover the top of the product with a piece of cloth or paper during installation. This is to prevent unwanted objects such as metal chippings, oil, and water from falling into the product and causing faults. After installation, remove the cloth or paper on top of the product to prevent over-temperature caused by poor ventilation due to blocked ventilation holes.• During installation, ensure the product is connected to the respective connector securely and hook the module firmly. Improper installation may result in malfunction, fault, or fall-off.

Wiring



- The equipment must be operated only by professionals with electrical knowledge. Non-professionals are not allowed.
- Before wiring, switch off all power supplies of the device. Wait for at least the time designated on the equipment warning label before further operations because residual voltage still exists after power-off. Measure the DC voltage of the main circuit and make sure that it is below the safety voltage. Failure to comply can result in the risk of electric shock.
- Do not perform wiring, remove the equipment cover, or touch the circuit board with power on. Failure to comply can result in the risk of electric shock.
- Make sure that the equipment and product are grounded properly. Failure to comply can result in the risk of electric shock. Ground the equipment separately or to a single point. Common grounding must not be used.

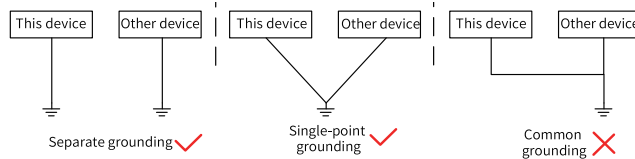

- Perform good insulation on terminals so that insulation distance between cables will not reduce after cables are connected to terminals. Failure to comply may result in electric shock or damage to the equipment.
- Install the terminal cover attached to the product before power-on or operation after wiring is completed. Failure to comply may result in electric shock.



- Never connect the power cable to output terminals of the equipment or product. Failure to comply may damage the equipment or even cause a fire.
- Cables used for wiring comply with the requirements for the cross sectional area and shielding. The shielding layer of the shielded cable must be reliably grounded at one end.
- Fix the terminal screws with the tightening torque specified in the user guide. Insufficient or excessive torque may cause overheating and damage of the joint, which could result in a fire.
- After wiring is done, check that all cables are connected properly and no screws, washers or exposed cables are left inside the equipment. Failure to comply may result in electric shock or equipment damage.













- Follow the proper electrostatic discharge (ESD) procedure and wear an anti-static wrist strap to perform wiring. Failure to comply may result in damage to the equipment or to the internal circuit of the product.
- Use shielded twisted pairs for the control circuit. Connect the shield to the grounding terminal of the equipment for grounding purpose. Failure to comply will result in equipment malfunction.

Power-on



- The equipment must be operated only by professionals with electrical knowledge. Non-professionals are not allowed.
- Before power-on, check that the equipment is installed and wired properly.
- Check that the power supply meets equipment requirements before power-on to prevent equipment damage or a fire.
- After power-on, do not open the cabinet door or protective cover of the equipment, touch any terminal, or disassemble any unit or component of the equipment. Failure to comply may result in death or personal injury.

Power-on
<p> WARNING</p> <p>Perform a trial run after wiring to ensure the equipment operates safely. Failure to comply may result in personal injury or equipment damage.</p>
Operation
<p> DANGER</p> <ul style="list-style-type: none">• The equipment must be operated only by professionals. Failure to comply can result in personal injury or death.• Do not touch any connecting terminals or disassemble any unit or component of the equipment during operation. Failure to comply can result in electric shock.
<p> WARNING</p> <ul style="list-style-type: none">• Do not touch the equipment enclosure, fan, or resistor with bare hands. Failure to comply may result in personal injury.• Prevent metal or other objects from falling into the equipment during operation. Failure to comply may result in a fire or equipment damage.• During operation, do not bring live parts into contact with the metal enclosure of the product. Failure to comply may result in a fire or equipment damage.
<p> CAUTION</p> <ul style="list-style-type: none">• Operate the product strictly within the required environmental conditions. Failure to comply may result in equipment fault or damage.• Touch the HMI panel with hands only during use. Do not use tools to touch the HMI panel. Ino Vance assumes no responsibility for panel damage caused by excessive external force. <p>Safety recommendations</p> <ul style="list-style-type: none">• In the position where the operator directly touches the machinery part, for example, where a machinery tool is loaded/unloaded, or where a machine runs automatically, manually-operated devices or similar must be installed independently of the product to start or stop the automatic operation of the system.• If you need to modify the program while the system is running, use the lock function or other protective measures. Ensure that only authorized personnel can make the necessary modifications.
Battery usage
<p> WARNING</p> <ul style="list-style-type: none">• Do not use batteries that do not meet the product requirements. Failure to comply may result in death, personal injury, explosion, or fire.• Do not throw batteries into a fire or heat oven. Do not crush or cut the battery. Failure to comply may result in death, personal injury, explosion, or fire.• Do not expose the battery to extremely high temperatures. Failure to comply may result in death, personal injury, explosion, or fire.• Do not swallow the battery to prevent the risk of chemical burns.• If a button battery is swallowed by accident, seek medical treatment immediately. Failure to comply may result in severe internal burns within two hours and could result in death.
<p> CAUTION</p> <ul style="list-style-type: none">• Keep the battery away from children.• If the battery compartment is not shut tight, stop using the device and keep it away from children.

Maintenance
<p> DANGER</p> <ul style="list-style-type: none"> • Maintenance and inspection must be carried out by personnel who have the necessary electrical training and experience. • Do not maintain the equipment with power ON. Failure to comply can result in electric shock. • Before maintenance, cut off all the power supplies of the equipment and wait for at least the time designated on the equipment warning label. • Disconnect all external power supplies of the system before cleaning the product or re-tightening screws on the terminal block or screws of the connector. Failure to comply may result in electric shock. • Disconnect all external power supplies of the system before removing the product or connecting/removing wirings. Failure to comply may result in electric shock or malfunction.
<p> WARNING</p> <p>Perform routine and periodic inspection and maintenance on the equipment according to maintenance requirements and keep a maintenance record.</p>
Repair
<p> DANGER</p> <ul style="list-style-type: none"> • Product repair must be carried out by personnel who have the necessary electrical training and experience. • Do not repair the equipment with power ON. Failure to comply can result in electric shock. • Before inspection and repair, cut off all the power supplies of the equipment and wait for at least the time designated on the equipment warning label.
<p> WARNING</p> <ul style="list-style-type: none"> • Submit the repair request according to the warranty agreement. • When the fuse is blown or the circuit breaker or earth leakage circuit breaker (ELCB) trips, wait as specified on the product warning sign before power-on or further operations. Failure to comply may result in personal injuries, equipment damage or even death. • When the equipment is faulty or damaged, require professionals to perform troubleshooting and repair by following repair instructions and keep a repair record. • Replace quick-wear parts of the equipment according to the replacement instructions. • Do not use damaged equipment. Failure to comply may result in death, personal injury, or severe equipment damage. • After the equipment is replaced, check the wiring and set parameters again.
Disposal
<p> WARNING</p> <ul style="list-style-type: none"> • Dispose of retired equipment in accordance with local regulations and standards. Failure to comply may result in property damage, personal injury, or even death. • Recycle retired equipment by observing industry waste disposal standards to avoid environmental pollution. • Dispose of retired batteries as industrial waste according to local laws and regulations.

Safety Label

For safe equipment operation and maintenance, comply with the safety labels on the equipment. Do not damage or remove the safety labels. The following table describes the meaning of the safety labels.

To ensure safe operation, comply with equipment-related safety labels. The following table describes the meaning of the safety labels.

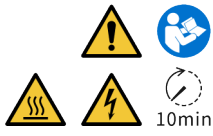
Safety Label	Description
	<ul style="list-style-type: none"> • Read through the safety instructions before operating the equipment. Failure to comply may result in death, personal injuries, or equipment damage. • Do not touch the terminals or remove the cover with power ON or within 10 min after power-off. Failure to comply will result in an electric shock. • The surface of the product may become very hot during operation. Do not touch these hot areas, as this may cause burns!

1.2 Industrial Information Safety

The product provides interfaces for network connection and data transmission. To protect factories, systems, machines, and networks from cyber attacks, it is essential to implement proper protection mechanism for industrial security.

Customers are responsible for providing and maintaining a secure connection between the product and their network or any other network to protect their factories, systems, machines, and networks from unauthorized access. Such systems or machines can be connected to an enterprise network or the Internet only when a secure connection is established and appropriate security measures (such as using antivirus software or installing firewalls) are in place.

Inovance continuously develops and improves its products and solutions to make them secure. It is strongly recommended that you update the product promptly and always use the latest version.

Caution

Malware (such as viruses, Trojans, and worms) can bring the device into an unsafe operating state, resulting in death, serious injury, and property damage. Observe the following precautions strictly:

- Always use the latest software version. If the product version is no longer supported or the latest program version is not applied, customers are at increased risk of cyberattacks.
 - Implement and maintain appropriate security measures (including but not limited to deploying anti-virus software, firewall, WAF, IPS/IDS, situational awareness system, ID verification, and data encryption) to prevent files in the removable storage device from being damaged by malware and to protect products, networks, systems, and interfaces from unauthorized access, disruption, intrusion, data leakage, or information theft.
 - Check all safety-related interfaces and settings after commissioning.
-

2 Product Introduction

GL20-2S485 (does not support Modbus protocol stack processing) and GL20-2S485-MDB (supports Modbus protocol stack processing) are both 2-channel RS485 communication modules, compatible with GL20 series communication interface modules, such as GL20-RTU-ECT32.

3 Model and Nameplate

Model

GL 20 -2 S485 -MDB

① ② ③ ④ ⑤

① Product information GL: General local module	③ Number of channels 2: Two channels	⑤ Protocol MDB: Modbus protocol
② Series 20: 20 series module	④ Module type S485: RS-485 communication module	-

Nameplate

- GL20-2S485 nameplate information:



INOVANCE

GL20-2S485
2-Port 485 Module
POWER INPUT: NONE
OUTPUT: NONE
SN: 0123456789123456

QC PASSED

Certification

COM1

COM2

Connector Pins
COM1/COM2

1	•
2	RS485+
3	•
4	•
5	GND
6	•
7	RS485-
8	•
9	•
SHELL	PE

MANUAL www.inovance.com
Suzhou Inovance Technology Co., Ltd. Made in China

- GL20-2S485-MDB nameplate information:



INOVANCE

GL20-2S485-MDB
2-Port 485 Module
POWER INPUT: NONE
OUTPUT: NONE
SN: 0123456789123456

QC PASSED

Certification

COM1

COM2

Connector Pins
COM1/COM2

1	•
2	RS485+
3	•
4	•
5	GND
6	•
7	RS485-
8	•
9	•
SHELL	PE

MANUAL www.inovance.com
Suzhou Inovance Technology Co., Ltd. Made in China





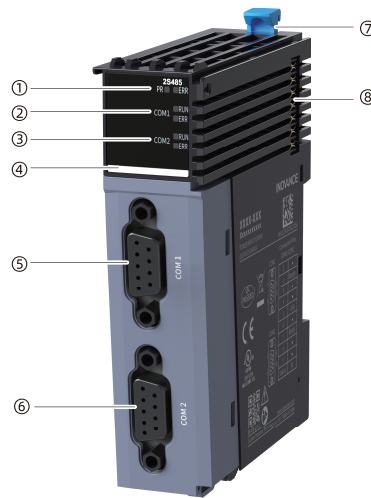

Based on the above description of model number and nameplate, the relevant ordering data of this product is described in the following table.

Model	Description	Product code	Applicable model
GL20-2S485-INT	GL20 series 2-channel RS-485 module	01441071	Applicable to GL20 series communication interface modules, such as GL20-RTU-ECT32
GL20-2S485-MDB-INT	GL20 series 2-channel RS-485 module (Modbus)	01441055	

4 Components

The GL20-2S485 and GL20-2S485-MDB models share identical components. The GL20-2S485 is used as an example in the following description.



No.	Name	Description			
①	Signal indicator	PR (POWER +RUN)	Power/Operation indicator	Yellow-green	<ul style="list-style-type: none"> • Steady ON: The module is in normal operation. • Fast flashing: The module is addressed successfully. • Slow flashing: The module is powered on but not addressed. • OFF: The module is not powered on or is faulty.
		ERR	Fault indicator	Red	ON: The module is faulty.
②	COM1 indicator	RUN	Operation indicator	Green	<ul style="list-style-type: none"> • Steady ON: The data communication is in progress. • OFF: No data communication is available.
		ERR	Fault indicator	Red	ON: The module is faulty.
③	COM2 indicator	RUN	Operation indicator	Green	<ul style="list-style-type: none"> • Steady ON: The data communication is in progress. • OFF: No data communication is available.
		ERR	Fault indicator	Red	ON: The module is faulty.
④	Color identification		Red: Digital output		Orange: Analog output
			Gray: Digital input		Green: Analog input
			White: Communication		Blue: Other modules
⑤	COM1 port	COM1	RS485 serial communication port 1 (DB9 female connector)	-	-

Components

No.	Name	Description			
⑥	COM2 port	COM2	RS485 serial communication port 2 (DB9 female connector)	-	-
⑦	Rail mounting latch	Used to secure the module to the DIN rail.			
⑧	Three-position terminal block	Used for backplane bus power supply and communication.			

Note

- Fast flashing: The indicator is on for 50 ms and off for 500 ms, cycling continuously.
 - Slow flashing: The indicator is on for 200 ms and off for 1 s, cycling continuously.
-

5 Terminal Assignment

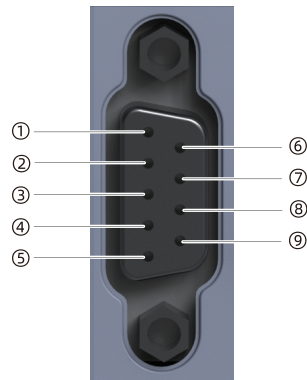

No.	Description
②	RS485+
⑦	RS485-
⑤	GND
①/③/④/⑥/⑧/⑨	-
Enclosure	PE

6 GL20-2S485-MDB Product Functions

6.1 Modbus-RTU and Free Protocol Commands Configuration Through IOManager Software

This configuration method is available for scenarios where the module is used to configure startup parameters of the MDB module, Modbus-RTU protocol commands, and free protocol commands for Beckhoff PLCs and Omron PLCs. The IOManager software supports both polling and trigger modes on a single serial port, and allows users to set the mapping addresses of slave coils, discrete inputs, registers in the module process data within the master buffer area.

Prerequisite

The following hardware devices and software/files have been prepared.

Type	Description
Hardware device	1x GL20-2S485-MDB communication module
	1x GL20-RTU-ECT32 communication interface module
	1x Type-C USB cable
	1x PC
Software/File	Obtain the XML file (without startup parameters) for GL20-RTU-ECT32 communication configuration version 3.0.14.1 from the Inovance official website: https://www.inovance.com/global/ .
	Obtain IOManager software version 2.0.6.0 or later from Inovance technical support.

Procedure

Note

The GL20-2S485-MDB and GL20-RTU-ECT32 modules are displayed as "GL20-2S485-MDB" and "GL20-RTU-ECT32" in the software.

1. Connect the device.

- a. Insert the Type-C USB cable into the USB port on the GL20-RTU-ECT32 communication interface module, as shown in the figure below.

2. Configure parameters.

- a. Click "Upload topology". The device tree in the left pane displays the current communication interface module and the modules mounted after it. Click the "GL20_2S485_MDB" module in the device tree to enter its parameter configuration interface, as shown below.

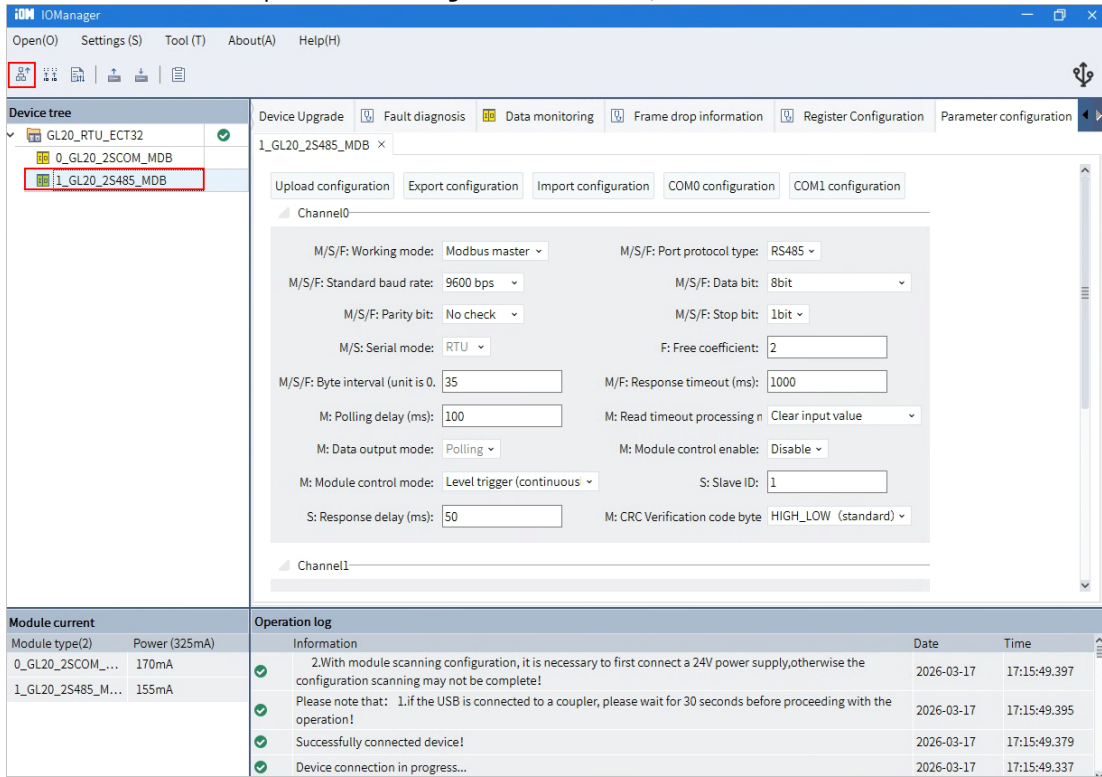

Parameter	Description	Default value
M/S/F: Operation mode	Modbus-RTU master, Modbus-RTU slave, free protocol	-
M/S/F: Port protocol type	RS485	RS485
M/S/F: Standard baud rate	4800 bps, 9600 bps, 19200 bps, 38400 bps, 57600 bps, and 115200 bps	9600 bps
M/S/F: Data bit	7 bits or 8 bits	8 bits
M/S/F: Parity bit	Odd parity, even parity, no parity	No parity
M/S/F: Stop bit	1 bit or 2 bits	1 bit
M/S: Serial mode	RTU	RTU
M/F: FreePort-coefficient	0-255. In general, use the default value 02. If the module operates as a master or in free protocol mode and needs to immediately pull the RTS pin low to receive data from the slave after transmission, set this value to 0.	2
M/S/F: Character pitch (unit: 0.1 characters)	Frame interval detection time when receiving messages. Range: 35 to 10000. Unit: 0.1 characters.	35
M/F: Response timeout (ms)	Maximum time the master waits for a response from the slave. Range: 10 to 65535. Unit: ms.	1000
M: Polling delay (ms)	Delay between the master receiving a response from the slave and sending the next command. Range: 0-65535. Unit: ms.	100
M: Read timeout handling method	Retain the last input value or clear the input value.	Maintain the last input value

Parameter	Description	Default value
M: Slave ID	Range: 1 to 247. This parameter is only valid in slave mode.	1
S: Response delay (ms)	Time during which the slave station sends the response message to the master station after receiving a query message. Range: 0 to 65535. Unit: ms. This parameter is only valid in slave mode.	50

Note

The descriptions of M/S/F are as follows.

- M: Parameters effective in Modbus master mode.
- S: Parameters effective in Modbus slave mode.
- F: Parameters effective in free protocol mode.

b. Click "Upload Configuration" to retrieve the current serial port configuration parameter information for channel 0/1 of the GL20_2S485_MDB module. Adjust the serial port configuration parameters of the module as needed, as shown in the figure below.

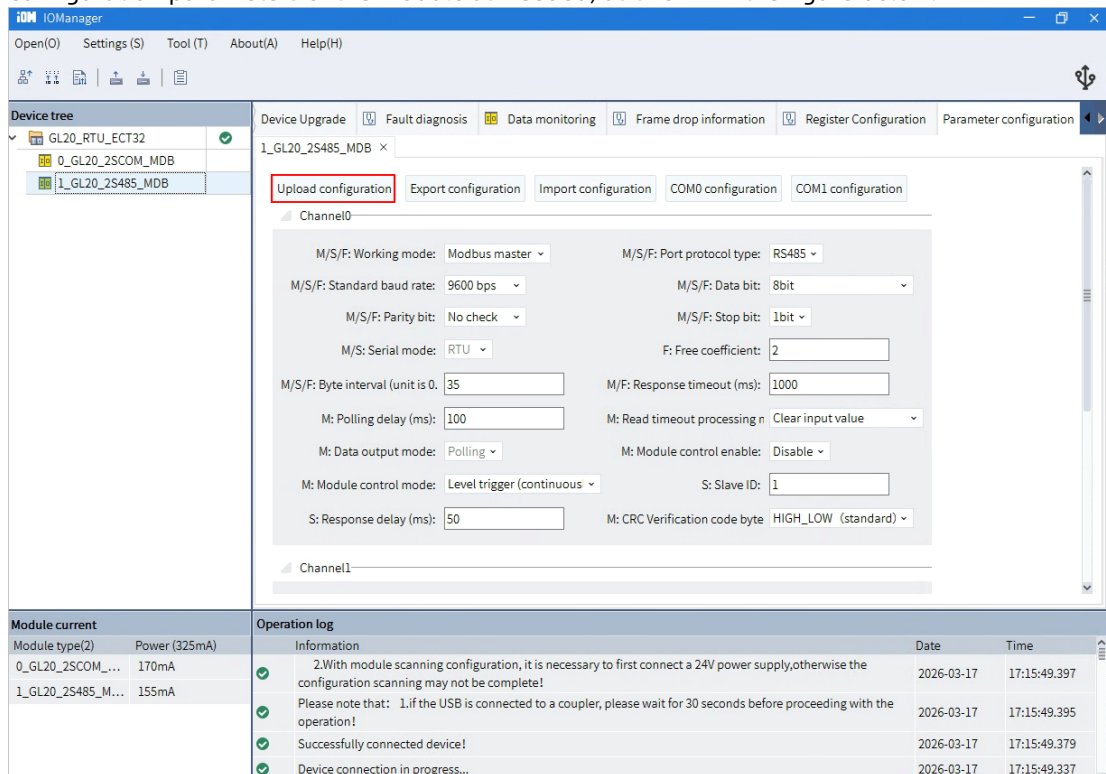

The screenshot displays the IOManager software interface. On the left, the 'Device tree' shows a hierarchy of modules: GL20_RTU_ECT32, 0_GL20_2SCOM_MDB, and 1_GL20_2S485_MDB. The main window is titled '1_GL20_2S485_MDB' and contains several tabs: 'Device Upgrade', 'Fault diagnosis', 'Data monitoring', 'Frame drop information', 'Register Configuration', and 'Parameter configuration'. The 'Parameter configuration' tab is active, showing settings for 'Channel 0'. A red box highlights the 'Upload configuration' button. The configuration parameters are as follows:

- M/S/F: Working mode: Modbus master
- M/S/F: Port protocol type: RS485
- M/S/F: Standard baud rate: 9600 bps
- M/S/F: Data bit: 8bit
- M/S/F: Parity bit: No check
- M/S/F: Stop bit: 1bit
- M/S: Serial mode: RTU
- F: Free coefficient: 2
- M/S/F: Byte interval (unit is 0): 35
- M/F: Response timeout (ms): 1000
- M: Polling delay (ms): 100
- M: Read timeout processing: Clear input value
- M: Data output mode: Polling
- M: Module control enable: Disable
- M: Module control mode: Level trigger (continuous)
- S: Slave ID: 1
- S: Response delay (ms): 50
- M: CRC Verification code byte: HIGH_LOW (standard)

At the bottom, the 'Module current' table shows power consumption for the modules:

Module type(2)	Power (325mA)
0_GL20_2SCOM_...	170mA
1_GL20_2S485_M...	155mA

The 'Operation log' table shows the following entries:

Information	Date	Time
2.With module scanning configuration, it is necessary to first connect a 24V power supply,otherwise the configuration scanning may not be complete!	2026-03-17	17:15:49.397
Please note that: 1.if the USB is connected to a coupler, please wait for 30 seconds before proceeding with the operation!	2026-03-17	17:15:49.395
Successfully connected device!	2026-03-17	17:15:49.379
Device connection in progress...	2026-03-17	17:15:49.337

c. Click "Parameter download configuration". When the serial port configuration parameter information for channel 0/1 has been downloaded, restart the communication interface module for the parameters to take effect, as shown in the figure below.

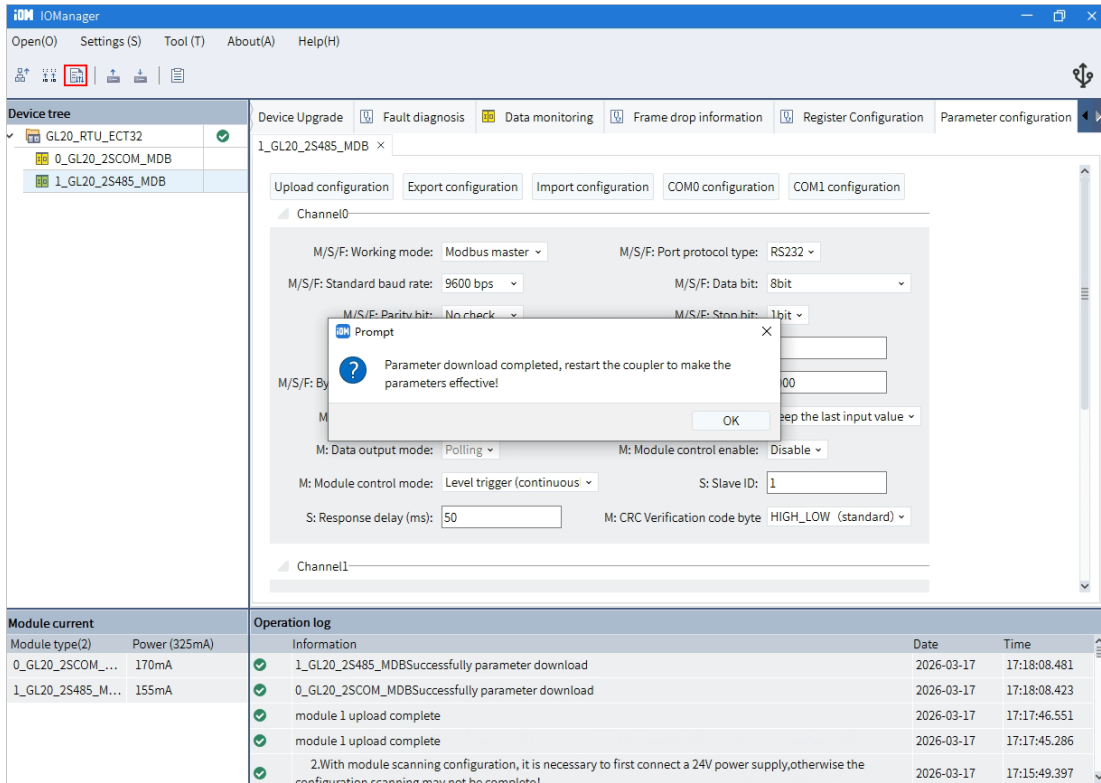

3. Configuration COM0/COM1 commands.

Click "COM0 Configuration" to add Modbus-RTU master commands or free protocol commands to serial port 0, and click "COM1 Configuration" to add Modbus-RTU master commands or free protocol commands to serial port 1, as shown below.

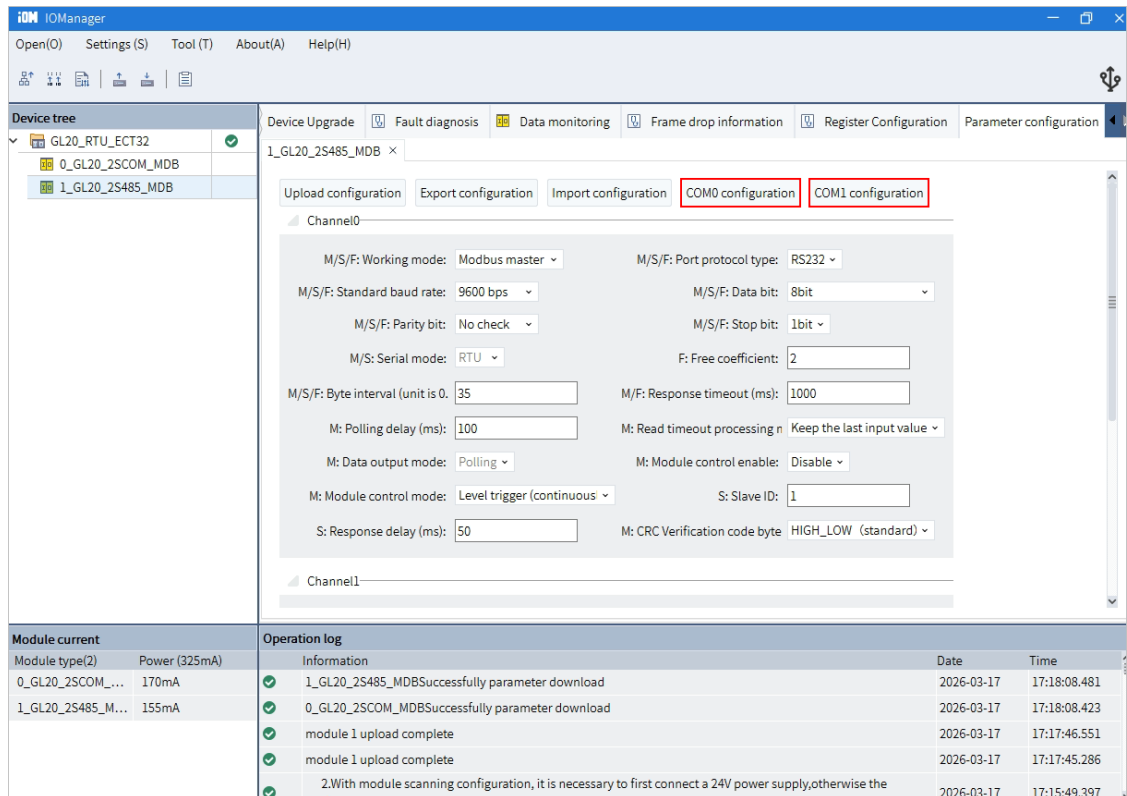

- When the GL20-2S485-MDB module operates as a Modbus-RTU slave, the maximum data area allowed for master read operations is 480 bytes of output process data, and the maximum data area allowed for master write operations is 480 bytes of input process data.
- When the GL20-2S485-MDB module operates as a Modbus-RTU slave, both COM0 and COM1 can be used for communication, but the two COM ports correspond to the same process data area.
- When the GL20-2S485-MDB module operates as a Modbus-RTU slave, parameters such as the slave ID and slave response delay are configured in the startup parameters, so there is no corresponding Modbus configuration interface. For example, when the master writes two holding registers to address 10, the values of these registers (4 bytes) are written into the 4-byte PDO starting from the 10th byte of the module input process data.

GL20-2S485-MDB master configuration interface

When "M/S/F: Operation Mode" is set to "Modbus master" for channel 0 and channel 1, the Modbus configuration items on the "COM0 Configuration" page and the "COM1 Configuration" page are the same. The following description uses the "COM0 Configuration" page as an example, as shown in the figure below.

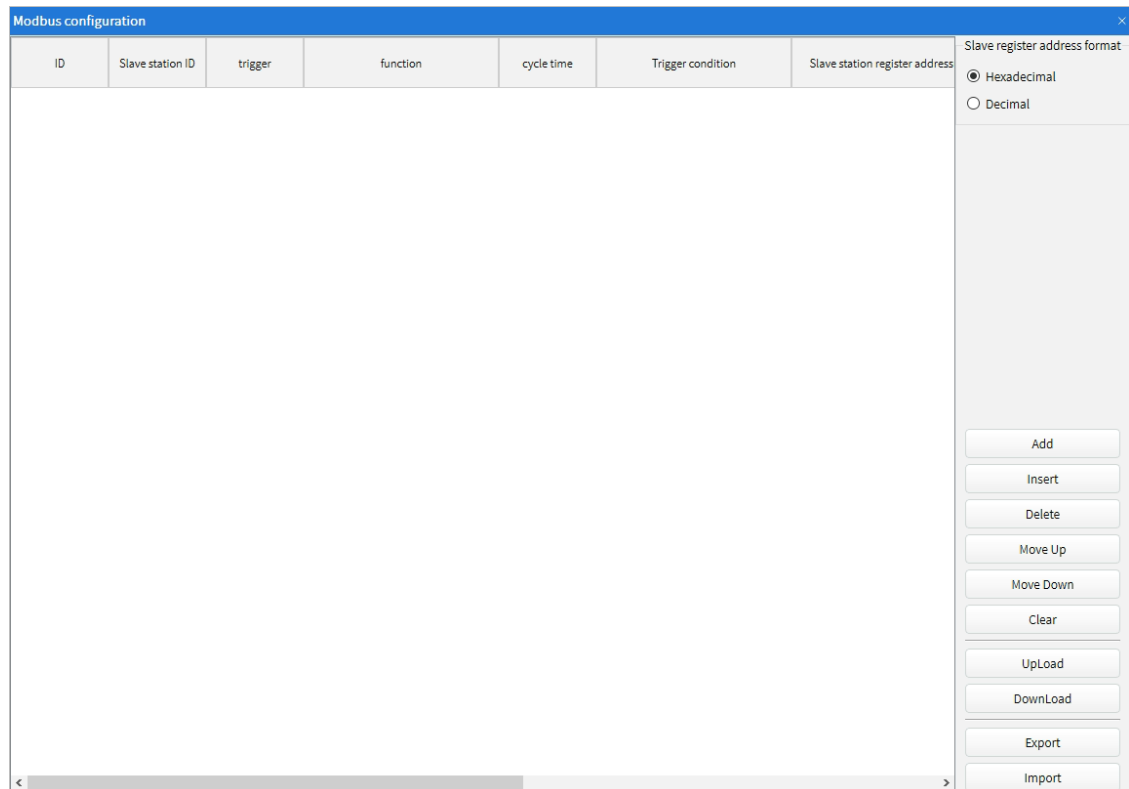

The functions are described in the following table.

- Slave address: Set the address of the Modbus-RTU slave to be connected. Valid range: 1 to 247. A single serial port can connect up to 31 slaves simultaneously. All 31 address rows can also be assigned to a single slave.
- Trigger mode, trigger condition, and cycle time: Supports both "Cycle" and "Trigger" modes, as shown in the figure below.
 - When "Cycle" is selected, the "Cycle time" parameter is used to set the command cycle time in ms.

- When "Trigger" is selected, the "Trigger condition" parameter is used to set the trigger condition element. In this mode, a single communication is triggered by setting the trigger condition. Upon successful communication completion (with a normal response from the slave), the status module indicates the communication status. A trigger example is shown below.

ID	Slave station ID	trigger	function	cycle time	Trigger condition	Slave station register address	The data length :coil:Bit registers:Word:	Main station buffer address	Slave register address format
1	1	循环	控制输出 (20) : 8字节	100	ControlOut[0].Bit0	0	1	0	<input type="radio"/> Hexadecimal <input checked="" type="radio"/> Decimal
2	1	触发	读保持寄存器 (03)	100	ControlOut[0].Bit0	1000	1	0	
3	2	触发	读保持寄存器 (03)	100	ControlOut[0].Bit4	2000	1	5	
4	1	循环	状态反馈 (17) : 8字节	100	ControlOut[0].Bit0	0	1	10	

Position	Port	Descript	R/W	Data Type	Value (MSB to LSB)	Variable
EtherCAT Network Configuration						
GL20(GL20S)-RTU-ECT32						
Device RPDO mapping paramete_Control word_FB00_00						
Device TPDO mapping paramete_LBus Status_F100_01						
Device TPDO mapping paramete_Fault ID_F100_02						
ErrorSlot TPDO mapping param_ErrorSlot1_F110_01						
ErrorSlot TPDO mapping param_ErrorSlot2_F110_02						
GL20-2SCOM-MDB						
GL20-2S485-MDB						
2S485-MDB Output0 mapping_2S485-MDB_Frame0_TX_0_7000_01						
		[0]	W	BYTE	00011000	
		[1]	W	BYTE	00000000	
		[2]	W	BYTE	00000000	
		[3]	W	BYTE	00000000	
		[4]	W	BYTE	00000000	
		[5]	W	BYTE	00000000	
		[6]	W	BYTE	00000000	
		[7]	W	BYTE	00000000	

No.	Description
①	This bit is the trigger condition ControlOut[0].bit4, which controls trigger No. 3 to read the holding registers from slave 2.
②	This bit is the trigger condition ControlOut[0].bit0, which controls trigger No. 2 to read the holding registers from slave 1.
③	The control output command consumes 4 bytes of output process data. The master buffer address for the control output command is set to 0, so the output process data [0]-[3] are used to trigger the Modbus command.

Position	Port	Description	R/W	Data Type	Value	Variable
EtherCAT Network Configuration						
Node100	GL20(GL20S)-RTU-ECT32	Device RPDO mapping paramete_Control word_FB00_00	W	UINT	0	
		Device TPDO mapping paramete_LBus Status_F100_01	R	UINT	8	
		Device TPDO mapping paramete_Fault ID_F100_02	R	UINT	0	
		ErrorSlot TPDO mapping param_ErrorSlot1_F110_01	R	UDINT	1	
		ErrorSlot TPDO mapping param_ErrorSlot2_F110_02	R	UDINT	0	
Slot 0	GL20-2SCOM-MDB					
Slot 1	GL20-2S485-MDB					
		2S485-MDB Output0 mapping_2S485-MDB_Frame0_TX_0_7000_01	W	ARRAY[0..29] OF BYTE		
		2S485-MDB Output0 mapping_2S485-MDB_Frame0_TX_1_7000_02	W	ARRAY[0..29] OF BYTE		
		2S485-MDB Output0 mapping_2S485-MDB_Frame0_TX_2_7000_03	W	ARRAY[0..29] OF BYTE		
		2S485-MDB Output0 mapping_2S485-MDB_Frame0_TX_3_7000_04	W	ARRAY[0..29] OF BYTE		
		2S485-MDB input0 mapping_2S485-MDB_Frame0_RX_0_6000_01	R	ARRAY[0..29] OF BYTE		
		[0]	R	BYTE	16#B	
		[1]	R	BYTE	16#B8	
		[2]	R	BYTE	16#0	
		[3]	R	BYTE	16#0	
		[4]	R	BYTE	16#0	
		[5]	R	BYTE	16#0	
		[6]	R	BYTE	16#0	
		[7]	R	BYTE	16#0	
		[8]	R	BYTE	16#0	
		[9]	R	BYTE	16#0	
		[10]	R	BYTE	16#1	
		[11]	R	BYTE	16#0	
		[12]	R	BYTE	16#0	
		[13]	R	BYTE	16#0	
		[14]	R	BYTE	16#0	
		[15]	R	BYTE	16#0	

No.	Description
①	The value read from the holding register of slave 1 by trigger No. 2 is 16#0BB8.
②	The communication failed when the holding register of slave 2 is read by trigger No. 3.
③	<p>The status command itself consumes 4 bytes of input process data, and the command communication status can be obtained through status feedback.</p> <ul style="list-style-type: none"> • Status[0] is 16#01, binary 0000 0001. • Status[0].Bit0 corresponds to the status of the ControlOut[0].Bit0 control command. This command communication succeeded, so this bit is set to 1. • Status[0].Bit4 corresponds to the status of the ControlOut[0].Bit4 control command. This command communication failed, so this bit is set to 0 until communication succeeds. This bit becomes 1 after the successful communication.

- Function: Sets how the master communicates with slaves.
- Slave register address: The address of the slave station register to be accessed. Modify the display format (hexadecimal or decimal) by selecting the slave station register address format.
- Data length: Number of coils, discrete quantities, or registers to be accessed.
- Master buffer address: Mapping positions of the slave coils/discrete quantities/registers in the master module process data.

Example:

Original mode

Modbus configuration

1. Read 1 register (PDO size: 2 bytes)
2. Read 17 coils (PDO size: 3 bytes)

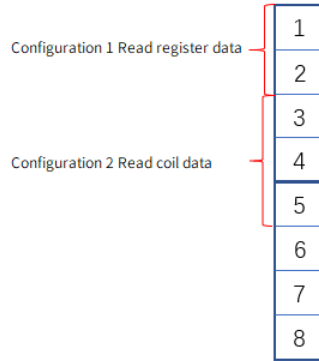

Tool-based configuration mode

Modbus configuration

1. Read 1 register (mapped address 1)
2. Read 17 coils (mapped address 5)

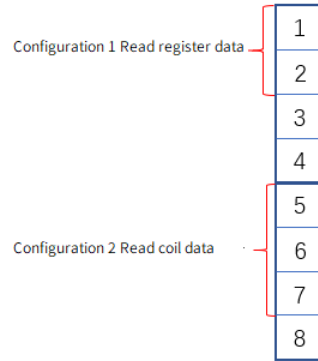

- Number of retries: Number of retries after the slave station response times out.



Caution

The total read data from both serial ports must not exceed 480 bytes, and the total write data must not exceed 480 bytes.

Free protocol configuration interface

When "M/S/F: Operation Mode" is set to "Free protocol" for channel 0 and channel 1, the configuration items on the "COM0 Configuration" page and the "COM1 Configuration" page are the same. The following description uses the "COM1 Configuration" page as an example, as shown in the figure below.

ID	Function	The data length < unit:Word >	Main station buffer address	communication mode	COM
1	控制与状态 (30)	输入8字节, 输出4字节	0	请求应答模式	1
2	输出数据 (32)	20	10	/	1
3	输入数据 (31)	20	10	/	1

Add
Insert
Delete
Move Up
Move Down
Clear
UpLoad
DownLoad
Export
Import

- The function and data length are described as follows.
 - Control and status (30): This function status feedback consumes 8 bytes of input process data, and the status control consumes 4 bytes of output process data. The description of each byte in the 8-byte status feedback input is shown in the following table.

Byte	Bit	Description	Note
Byte 1	bit0	Busy status	Serial port status
	bit1	Communication completion flag	
	bit2	Parity error	
	bit3	Timeout error	
	bit4 to bit7	Reserve	
Byte 2	Unsigned8	Reserve	-
Byte 3	Unsigned8	Receive error frame count (high byte)	-
Byte 4	Unsigned8	Receive error frame count (low byte)	-
Byte 5	Unsigned8	Total received data frame count (high byte)	-
Byte 6	Unsigned8	Total received data frame count (low byte)	-
Byte 7	Unsigned8	Receive error frame count (high byte)	-
Byte 8	Unsigned8	Receive error frame count (low byte)	-

The description of each byte in the 4-byte control output is shown in the following table.

Byte	Bit	Description	Note
Byte 1	bit0	Trigger control word	Control word
	bit1	Completion reset	
	bit2	Parity error reset	
	bit3	Timeout error reset	
	bit4	Error timer reset	
	bit5	Receive timer reset	
	bit6	Received data reset	
Byte 2	Unsigned8	Reserve	Valid data length: compatible with ECT (476 bytes) /PN (474 bytes). Defaults to maximum value if this limit is exceeded.
Byte 3	Unsigned8	Transmit frame byte length (high byte)	
Byte 4	Unsigned8	Transmit frame byte length (low byte)	

- Output data (32): This function allows users to set the data length (unit: Word). This data length specifies the size of the module data transmission buffer.
 - Input data (31): This function allows users to set the data length (unit: Word). This data length specifies the size of the module receive data buffer.
 - Master buffer address: Mapping positions of output/input data in the module output/input process data.
 - Communication modes are categorized into three types: receive-only, request-response, and transmit-only.
 - Receive-only: For example, a barcode scanner typically sends data actively, and the PLC or module only needs to receive data. However, the reception rules must be defined.
 - Request-response mode: For example, during the communication with a servo driver, a transmission must be sent and confirmed. In this mode, the PLC or module acts as the master.
 - Transmit-only: For example, the PLC or module acts as a slave and needs to send data to the master.
4. Download the COM0/COM1 command.
- a. Click "Download" so that the device sends the configuration command to the GL20-2S485-MDB module, as shown in the figure below.

The screenshot shows the 'Modbus configuration' window with a table of 10 entries. A 'download progress' dialog box is overlaid on the table, indicating that the download is 72% complete. The dialog box has a green progress bar and a 'Cancel' button.

ID	Slave station ID	trigger	function	cycle time	Trigger condition	Slave station register address(H)	The data length < coil:Bit registers:Word >	station buffer adc	Resend tim
1	1	循环	控制输出 (20) : 8字节	100	ControlOut[0].Bit0	0	1	0	1
2	1	循环	读线圈 (01)	100	ControlOut[0].Bit0	0	1	5	1
3	1	循环	读输入离散量 (02)	100	ControlOut[0].Bit0	0	1	10	1
4	1	循环	读保持寄存器 (03)	100	ControlOut[0].Bit0	0	1	11	1
5	1	循环	读输入寄存器 (04)	100	ControlOut[0].Bit0	0	1	14	1
6	1	触发	写单个线圈 (05)	100	ControlOut[0].Bit0	0	1	0	1
7	1	触发	写单个寄存器 (06)	100	ControlOut[0].Bit1	0	1	1	1
8	1	循环	写多个线圈 (15)	100	ControlOut[0].Bit0	0	1	5	1
9	1	循环	写多个寄存器 (16)	100	ControlOut[0].			7	1
10	1	循环	状态反馈 (17) : 8字节	100	ControlOut[0].			10	1

b. After download completion, a pop-up window indicates Modbus configuration data have been downloaded successfully.

5. Upload the COM0/COM1 command.

a. When the current module command information needs to be retrieved, click "Upload" to read the command, as shown in the figure below.

The screenshot shows the 'Modbus configuration' window with the same table of 10 entries. An 'upload progress' dialog box is overlaid on the table, indicating that the upload is 95% complete. The dialog box has a green progress bar and a 'Cancel' button.

ID	Slave station ID	trigger	function	cycle time	Trigger condition	Slave station register address(H)	The data length < coil:Bit registers:Word >	station buffer adc	Resend tim
1	1	循环	控制输出 (20) : 8字节	100	ControlOut[0].Bit0	0	1	0	1
2	1	循环	读线圈 (01)	100	ControlOut[0].Bit0	0	1	5	1
3	1	循环	读输入离散量 (02)	100	ControlOut[0].Bit0	0	1	10	1
4	1	循环	读保持寄存器 (03)	100	ControlOut[0].Bit0	0	1	11	1
5	1	循环	读输入寄存器 (04)	100	ControlOut[0].Bit0	0	1	14	1
6	1	触发	写单个线圈 (05)	100	ControlOut[0].Bit0	0	1	0	1
7	1	触发	写单个寄存器 (06)	100	ControlOut[0].Bit1	0	1	1	1
8	1	循环	写多个线圈 (15)	100	ControlOut[0].Bit0	0	1	5	1
9	1	循环	写多个寄存器 (16)	100	ControlOut[0].			7	1
10	1	循环	状态反馈 (17) : 8字节	100	ControlOut[0].			10	1



Caution

Do not perform upload operations while the module is running.

b. After upload completion, a pop-up window indicates Modbus configuration data have been uploaded successfully.

6. Import the COM0/COM1 command.

a. After setting up the Modbus-RTU master commands or free protocol commands, click "Export" ①, select the current configuration file ②, click "Save" ③, and save the file as a *.csv file, as shown in the figure below.

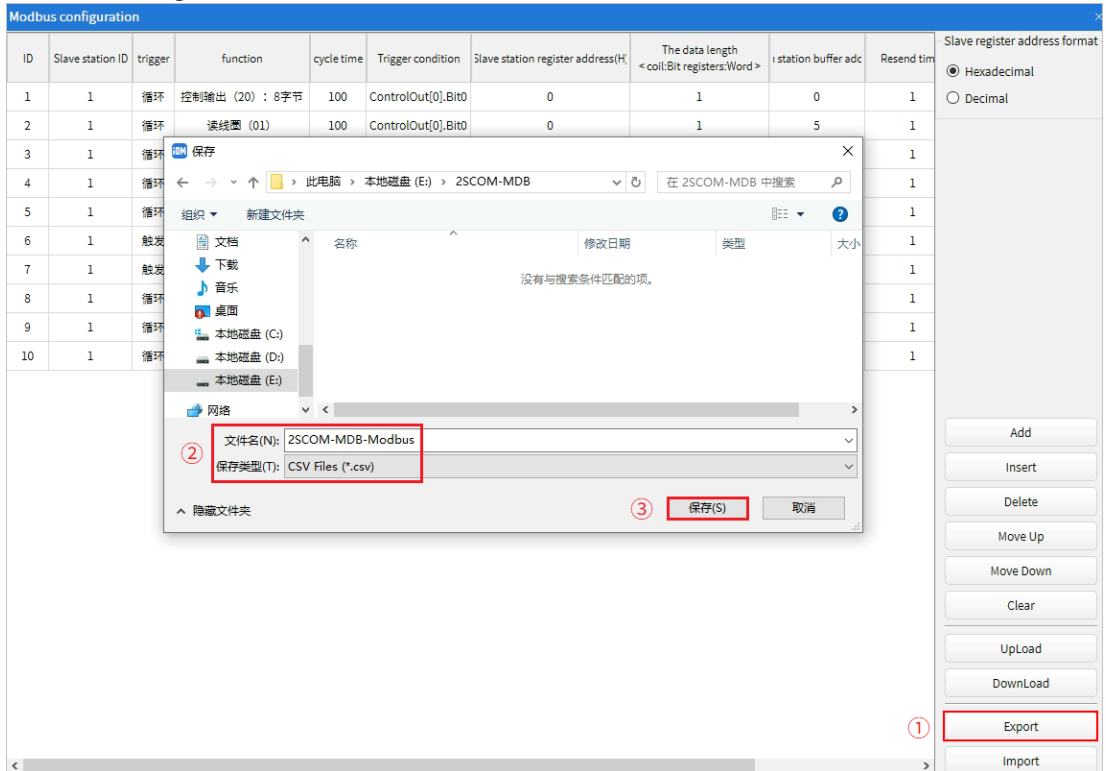

b. Click "Import" ①, select the corresponding .csv configuration file ②, and click "Open" ③ to import the saved command information into the current COM0/COM1 command configuration interface, as shown in the figure below.

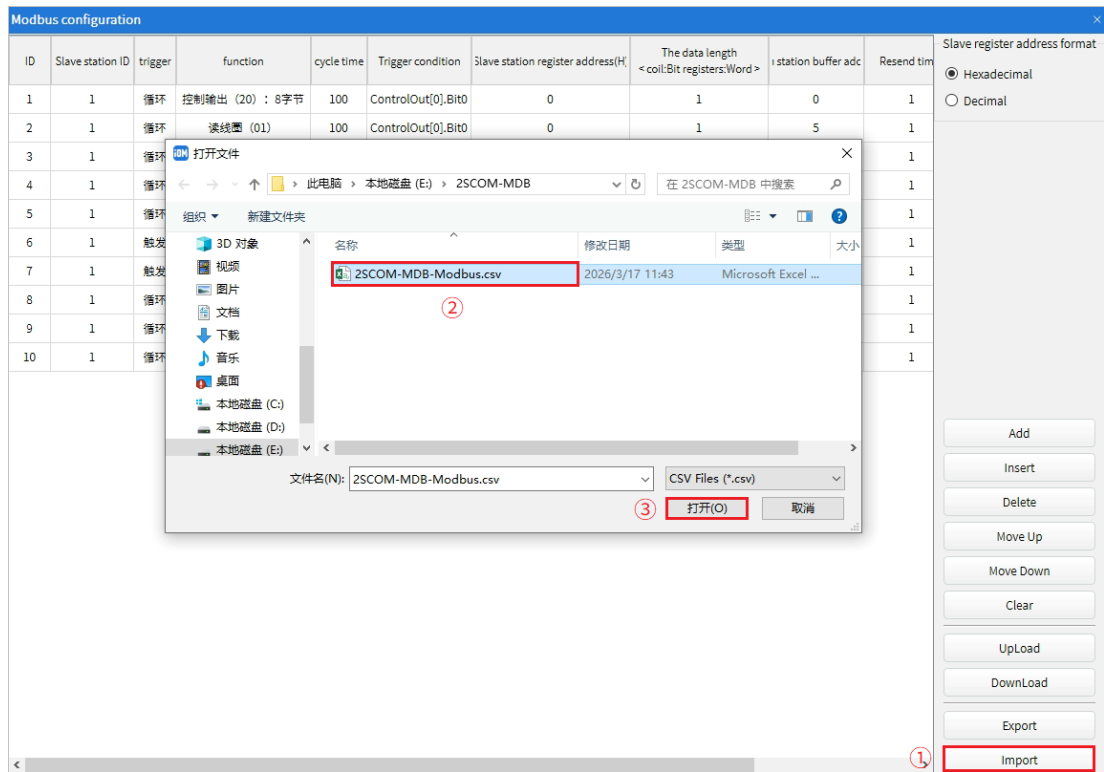

6.2 Set_Comm_ConfigItem Function Block

The Set_Comm_ConfigItem function block sets configuration items for the MDB module and is used to configure the Modbus-RTU protocol and free protocol commands of the MDB module for Beckhoff and Omron host systems.

Graphic block

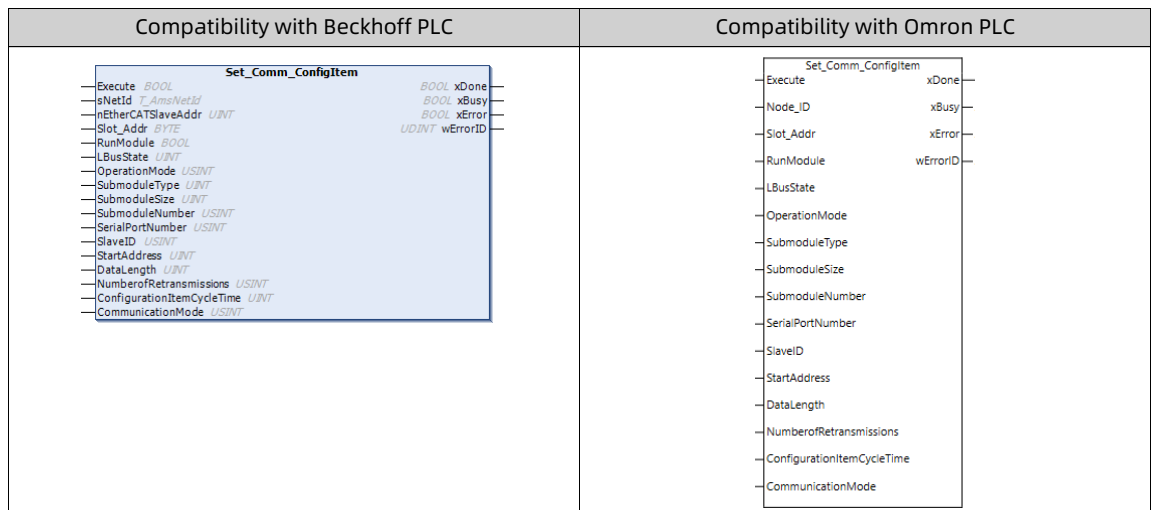

Note

Obtain the "Set_Comm_ConfigItem" function block from Inovance technical support.

Variables

Name	Data type	Description	Empty allowed	De fault value	Range
Execute	BOOL	Enable bit	No	-	ON/OFF
sNetId	T_AmsNetId	EtherCAT master port number (This input is valid for Beckhoff PLCs.)	No	-	-
nEtherCATSlaveAddr	BYTE	EtherCAT slave port number (This input is valid for Beckhoff PLCs.)	No	-	-
Node_ID	UINT	GL20-RTU-ECT32 communication interface module configuration node number (This input is valid for Omron PLCs)	No	-	-
Slot_Addr	BYTE	Position of the 2S485-MDB module within the GL20-RTU-ECT32 communication interface module	No	-	1 to 4
RunModule	BOOL	Start module (The local bus switches to OP state.)	Yes	-	ON/OFF
LBusState	UINT	Local bus state 0x01(1): Initialization state 0x02(2): Pre-operational state 0x04(4): Safe operation state 0x41(65): Large data configuration download state 0x08(8): Operational state	No	-	-
OperationMode	USINT	Operation mode 0: Modbus master; 1: Modbus slave; 2: Free protocol.	No	-	0 to 2
SubmoduleType	WORD	Submodule type	No	-	-
SubmoduleSize	WORD	Submodule PDO data size	No	-	-
SubmoduleNumber	USINT	Subslot number Up to 31 modules per serial port	No	-	1 to 62
SerialPortNumber	USINT	M/S/F: Serial port number 0: COM0; 1: COM1	No	-	0 to 1
SlaveID	USINT	M: Slave ID number	Yes	-	1 to 247
StartAddress	WORD	M/S: Start address	Yes	-	0 to 65535
DataLength	USINT	M: Data length	Yes	-	-
NumberOfRetransmissions	USINT	M: Retransmission count	Yes	-	0 to 2
ConfigurationItemCycleTime	WORD	M: Cycle time	Yes	-	0 to 65535
CommunicationMode	USINT	F: Communication mode 0: Receive-only; 1: Request-response mode; 2: Transmit-only.	Yes	-	0 to 2
xDone	BOOL	Completion flag	No	OFF	ON/OFF
xBusy	BOOL	Execution state	No	OFF	ON/OFF
xError	BOOL	Error flag	No	OFF	ON/OFF
wErrorID	WORD (Omron) UDINT (Beckhoff)	Fault code	No	0	-

Function instruction description

Note

The GL20-2S485-MDB and GL20-RTU-ECT32 modules are displayed as "GL20-2S485-MDB" and "GL20-RTU-ECT32" in the software.

- "sNetId" is the EtherCAT master address. In the project, double-click EtherCAT to determine the EtherCAT address of the master station. This address is the NetId for non-PLC devices, as shown in the figure below.

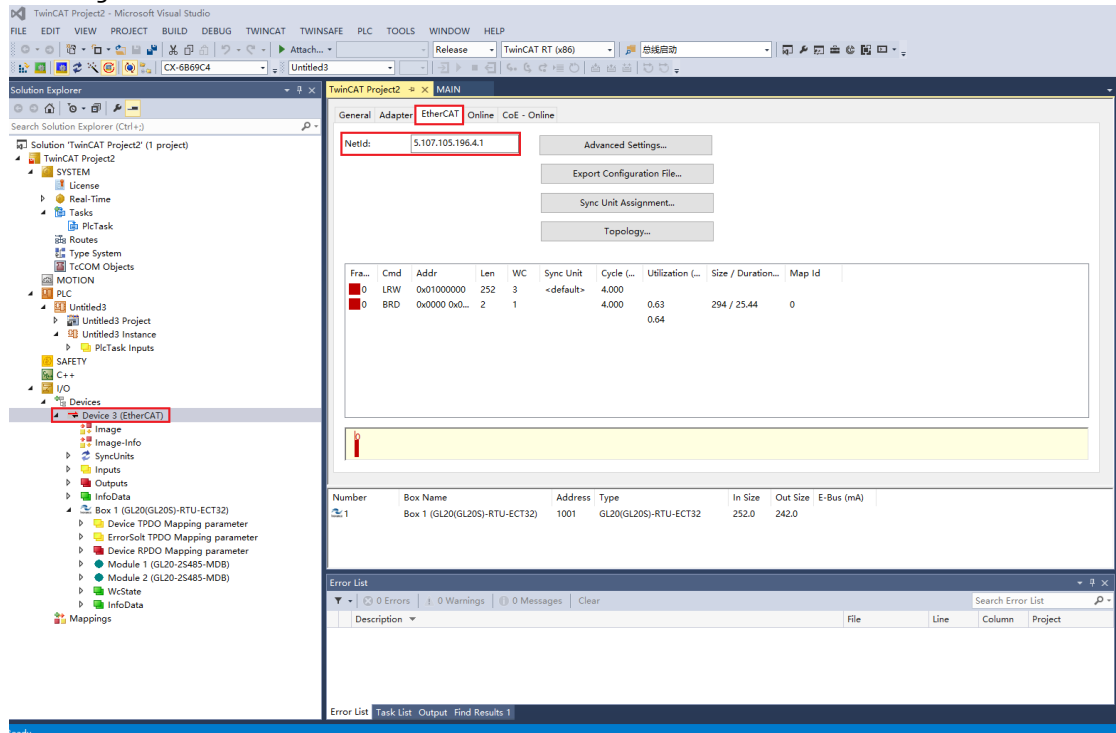

- "Slot_Addr" indicates the position of the GL20-2S485-MDB module after the GL20-RTU-ECT32 communication interface module. For example, if the GL20-2S485-MDB module is installed in the first position after the GL20-RTU-ECT32 communication interface module, then Slot_Addr is 1.
- "nEtherCATSlaveAddr" is the EtherCAT slave address. Determine the slave address of the module, as shown in the figure below.

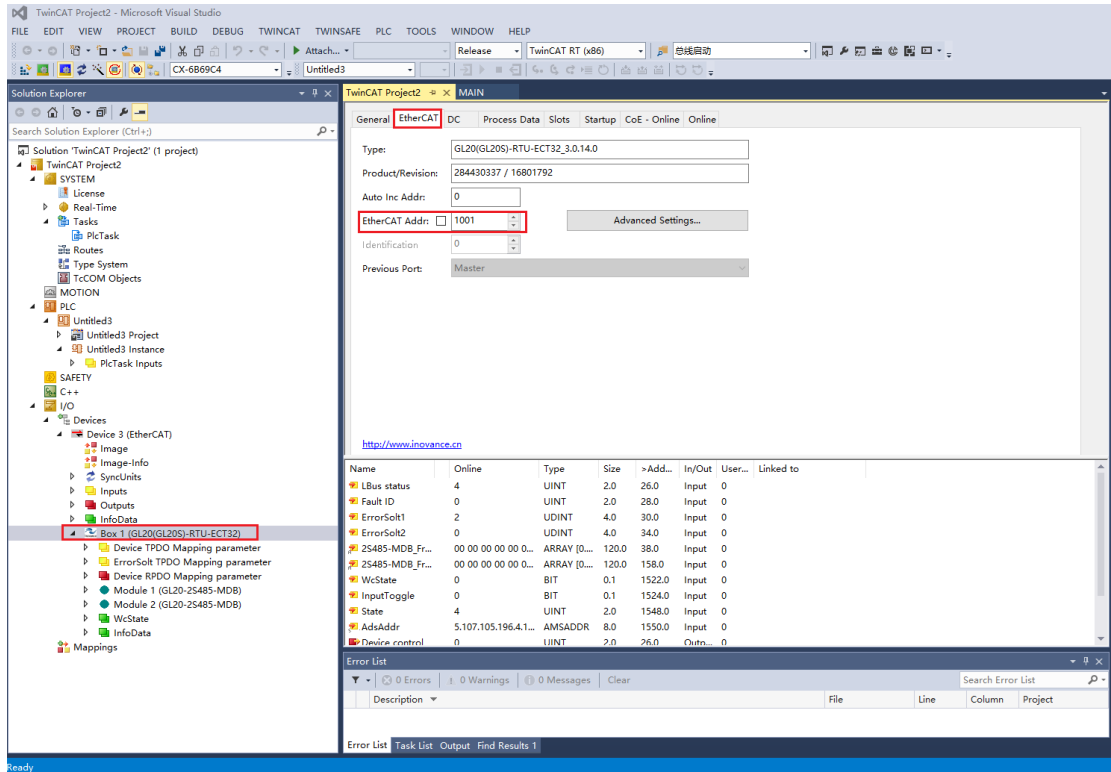

- Node_ID is the node number configured for the GL20-RTU-ECT32 communication interface module, which can be viewed after scanning IO devices. For example, Node_ID in the figure below is 22.
- After all configurations for the GL20-2S485-MDB module mounted on the GL20-RTU-ECT32 communication interface module are completed, RunModule is set to 1 to start the module.
- LBusState indicates the local bus state, enabling the function block to retrieve the local bus state.
 - When the local bus state is 0x41, a rising edge on Execute starts function block processing.
 - Upon module startup, the Done signal is set by detecting the local bus state transition from 0x41 to 0x08.
 - The steps for associating the LBusState pin with the local bus state are shown in the figure below.

For compatibility with Beckhoff PLCs, as shown in the figure below.

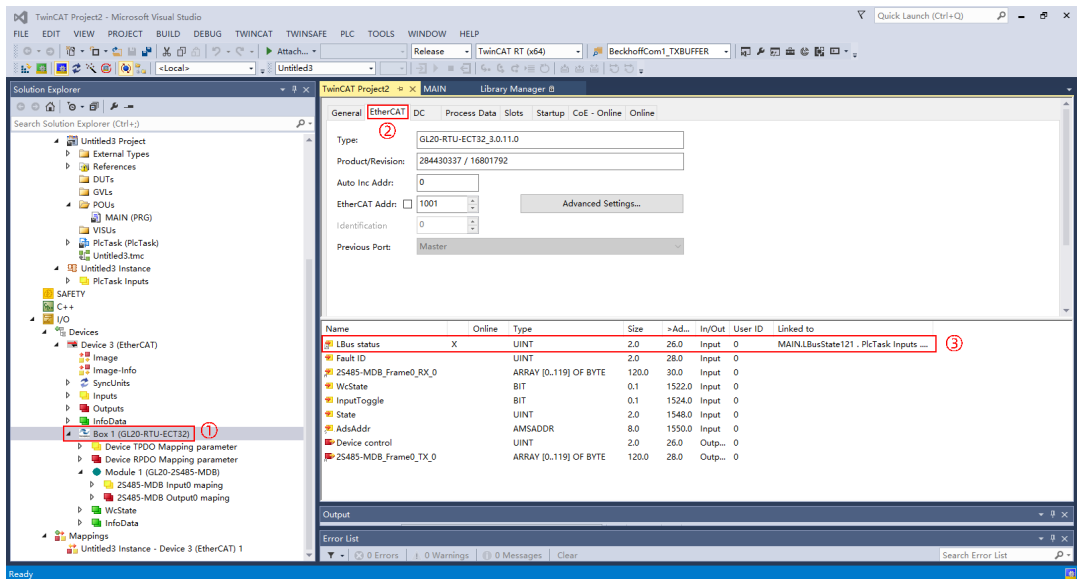

For compatibility with Omron PLCs, as shown in the figure below.

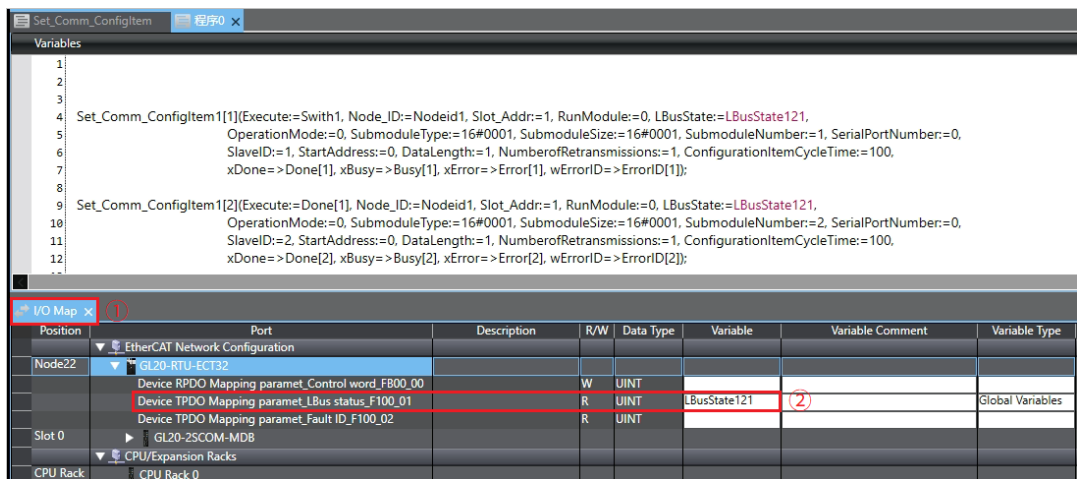

- The range of SubmoduleType is shown in the following figure.

SubmoduleType (Modbus master)	0x0001: Read coils 0x0002: Read discrete inputs 0x0003: Read holding registers 0x0004: Read input registers 0x0005: Write single coil 0x0006: Write single register 0x000F: Write coils 0x0010: Write holding registers 0x0013: Serial port polling time 0x0014: Module control output
SubmoduleType (Modbus slave)	0x0021: Read coils 0x0022: Read holding registers 0x0023: Write coils 0x0024: Write discrete inputs 0x0025: Write input registers 0x0026: Write holding registers
SubmoduleType (Free protocol)	0x0030: Control and status 0x0031: Input data 0x0032: Output data

- The ranges of SubmoduleSize and DataLength are shown in the following table.

Modbus master	SubmoduleSize range	DataLength range
01 Read coils, 02 Read discrete inputs	1 to 31 bytes	1 to 248 coils
03 Read holding registers, 04 Read input registers	1 to 125 words	1 to 125 registers
0F Write coils	1 to 31 bytes	1 to 248 coils
10 Write holding registers	1 to 123 words	1 to 123 registers
05 Write single coil	1 byte	1 coil
06 Write single register	1 word	1 register
13 Polling time	1 word	-
14 Module control output	1 to 4 bytes	-

- The relationship between the SubmoduleSize pin and the DataLength pin is described as follows.
 - When reading or writing coils, $DataLength \leq SubmoduleSize \times 8$. For example, when reading 1 to 8 coils, DataLength equals 1 to 8, and SubmoduleSize equals 1. When reading 9 to 16 coils, DataLength equals 9 to 16, and SubmoduleSize equals 2.
 - When reading and writing registers, $SubmoduleSize = DataLength$.

Modbus slave	SubmoduleSize range
21 Read coils (corresponding to master writing multiple/single coils)	1 to 246 bytes
22 Read holding registers (corresponding to master writing multiple/single registers)	1 to 123 words
23 Write coils (corresponding to master reading coils)	1 to 250 bytes
24 Write discrete inputs (corresponding to master reading discrete inputs)	1 to 250 bytes
25 Write input registers (corresponding to master reading input registers)	1 to 125 words
26 Write holding registers (corresponding to master reading holding registers)	1 to 125 words

Free protocol	SubmoduleSize range
30 Control & Status module	Do not use this pin. Note: The default input process data is 8 bytes, and the default output process data is 4 bytes.
31 Input data	1 to 128 words
32 Output data	1 to 128 words

Note

When the function block is called multiple times, the total configured SubmoduleSize must not exceed the maximum module process data size of 480 bytes. Otherwise, the module will report an error, and PDO data exchange will fail.

The "SubmoduleNumber" subslot number pin must be used. When calling the function block to send instructions to each GL20-2S485-MDB module, the subslot numbers must be assigned sequentially from 1 to 62. The function block will download configuration data to the corresponding module location according to the subslot number.

Note

For each GL20-2S485-MDB module, the value SubmoduleNumber (subslot number) must be set to 1 when the function block is used for the first time. If the value SubmoduleNumber (subslot number) is 1, the packet sequence number is 1. Upon detecting the first data packet, the module first erases the FLASH and then writes the new data. If data is written directly without prior erasing, the flash controller reports an error, disabling both write and erase operations.

The correspondence between Modbus configuration items and I/O mapping is as follows.

SubmoduleNumber	Configuration item	DataLength	SubmoduleSize
1	Read 1 register	1	1
2	Write 2 registers	2	2
3	Read 8 coils	8	1
4	Read 16 coils	16	2
5	Read 1 register	1	1
6	Writes 8 coils	8	1

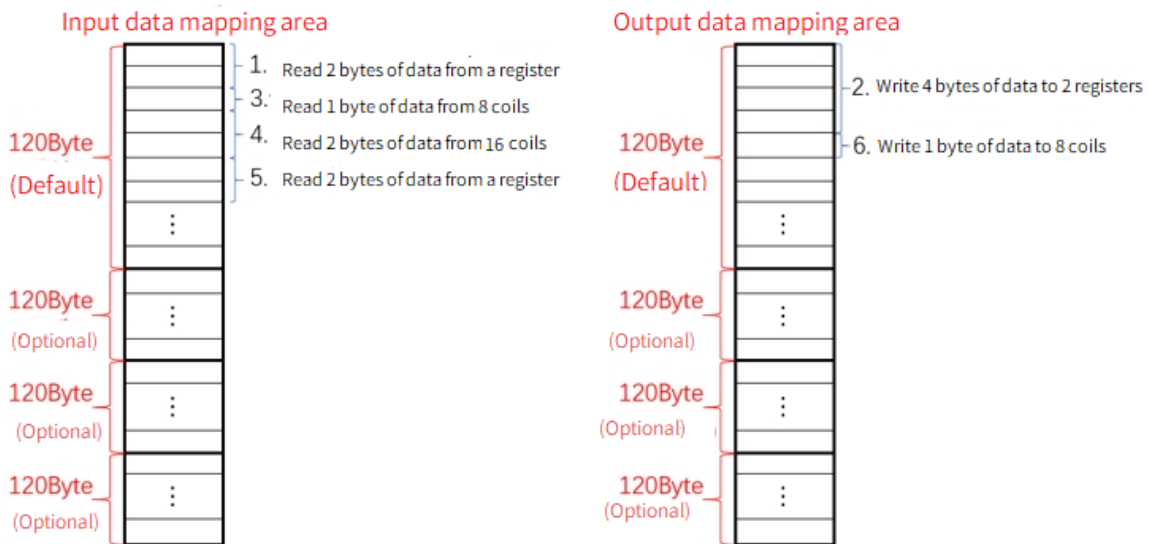

Program example

1. Install the library files for Beckhoff PLCs and Omron PLCs.
 - Install the library file for Beckhoff PLCs.
 - a. Double-click "References" in the PLC project, and select the "Library repository" tab, as shown in the figure below.

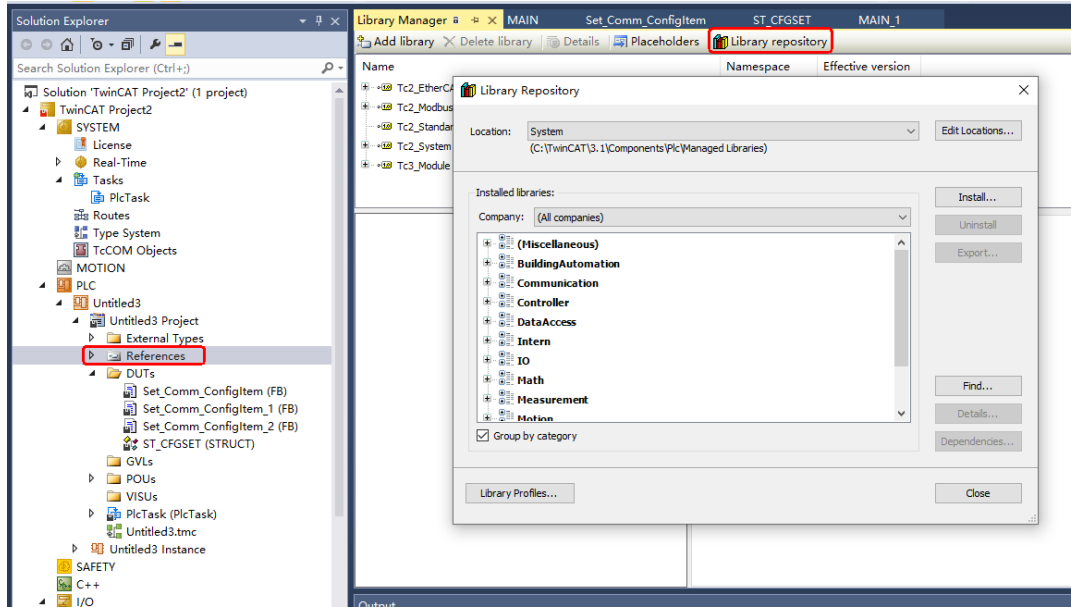

b. Click "Install", select the library file to be installed, and click "Open", as shown in the figure below.

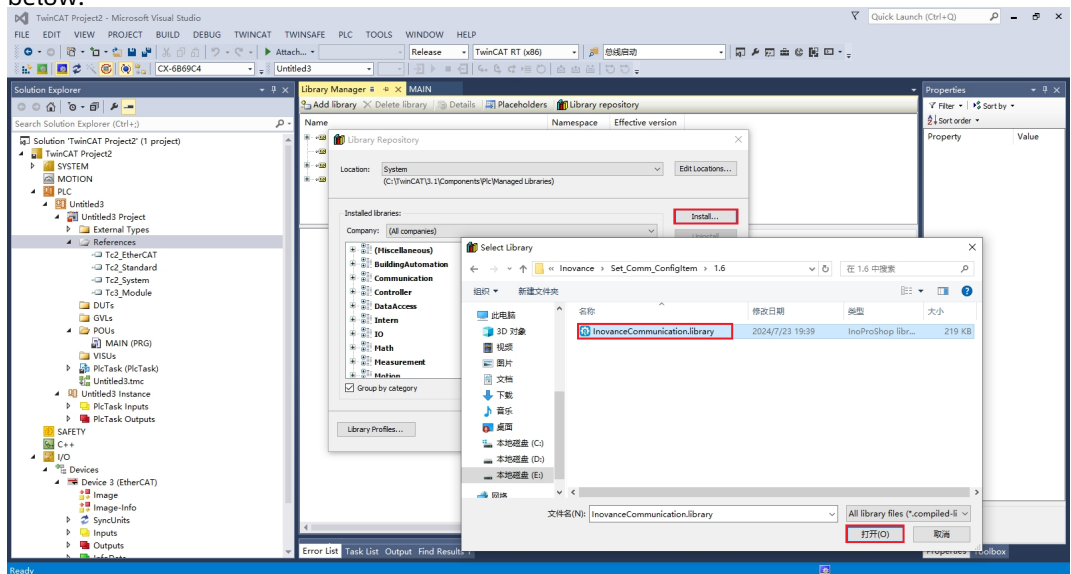

The following interface indicates that the library file has been successfully installed, as shown below.

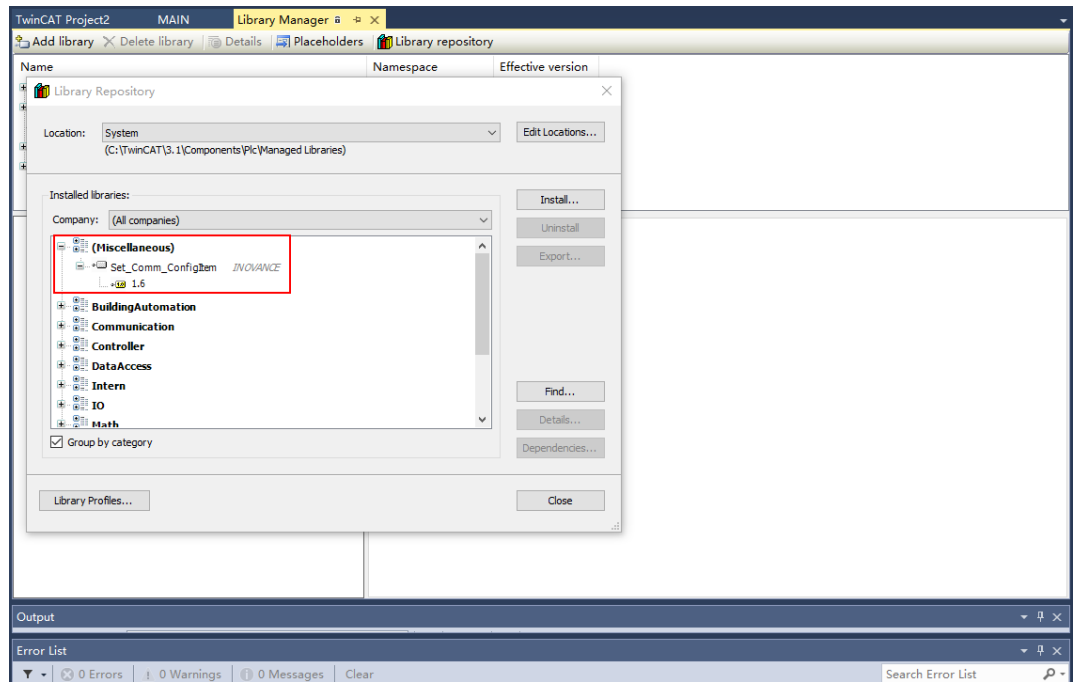

c. Select the "Add library" tab, select the installed library file, and click "OK", as shown in the following figure.

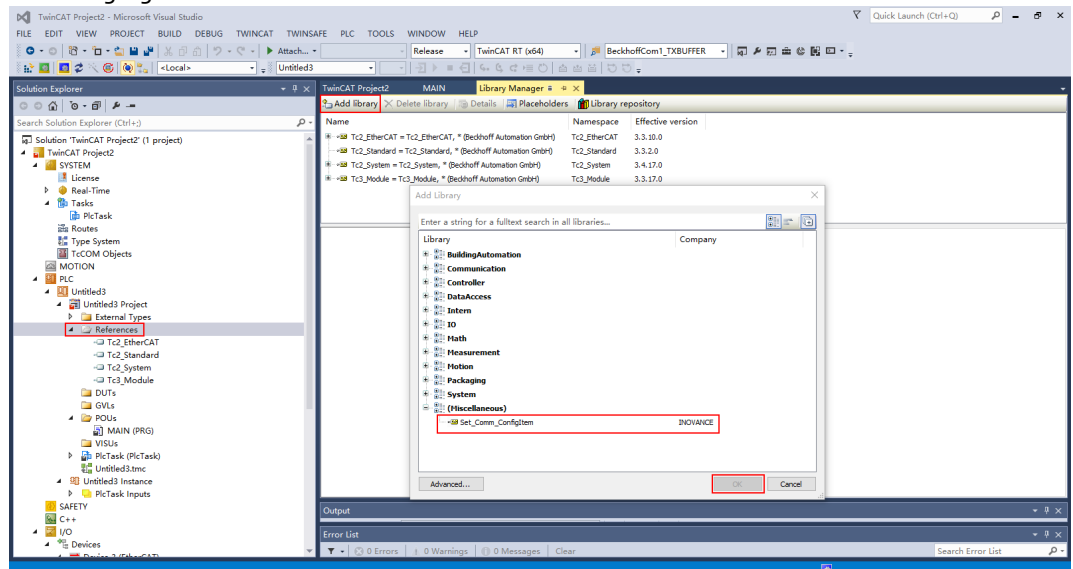

After the library file is referenced, the associated function repository blocks become available for use, as shown in the figure below.

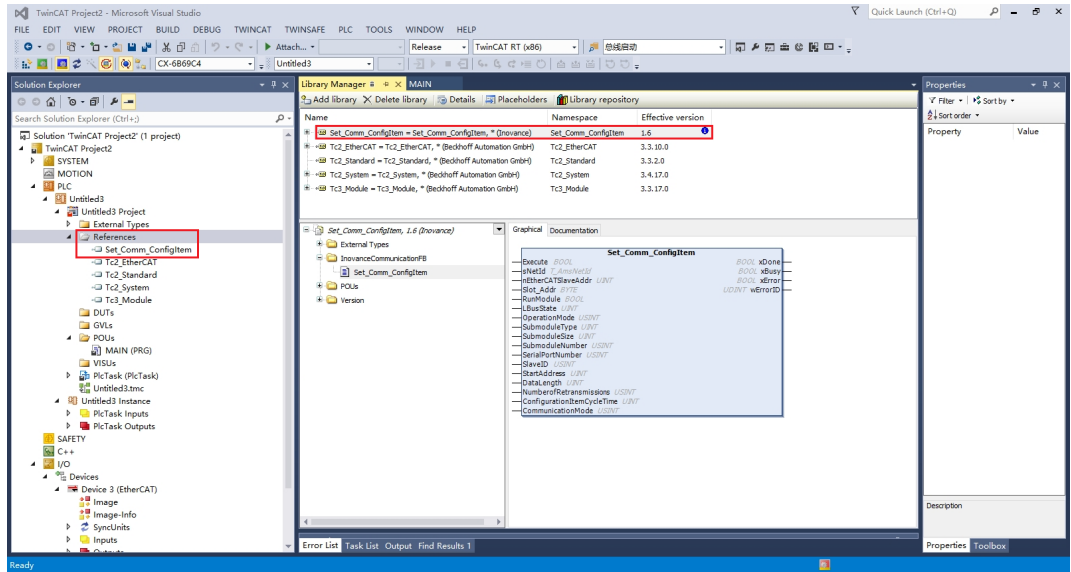

The Modbus master and slave function block usage example is shown in the figure below.

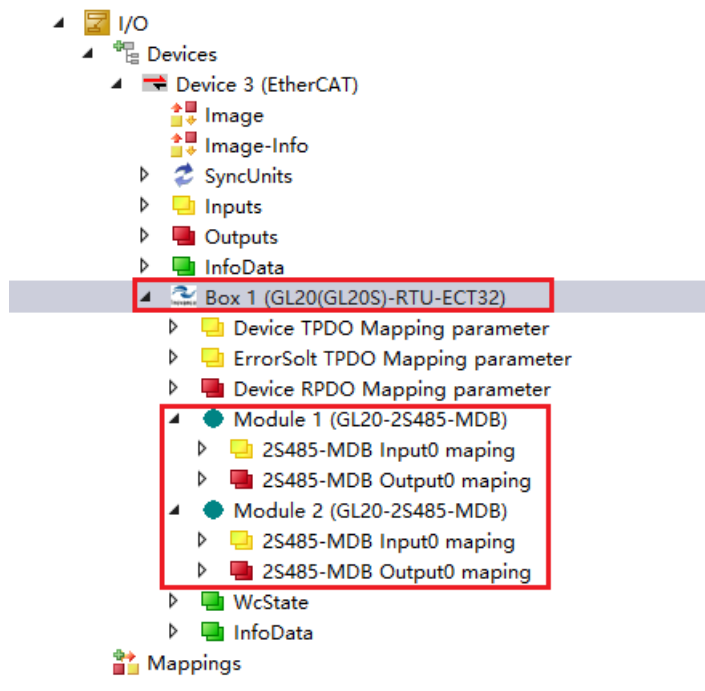

```

MAIN x Library Manager
20 sNetId : T_AmNetId := '5.107.105.196.4.1' ;
21 nSlaveAddr : UINT := 1001;
22
23
24 Set_Comm_ConfigItem1(Execute:=Switch1, sNetId := sNetId, nEtherCATSlaveAddr := nSlaveAddr, Slot_Addr := 1, RunModule:=0, LBusState:=LBusState1001,
25 OperationMode:=0, SubmoduleType:=164001, SubmoduleSize:=164001, SubmoduleNumber:=1, SerialPortNumber:=0,
26 SlaveID:=1, StartAddress:=0, DataLength:=1, NumberOfRetransmissions:=1, ConfigurationItemCycleTime:=100,
27 xDone:=Done1, xBusy:=Busy1, xError:=Error1, xErrorID:=ErrorID1);
28
29 Set_Comm_ConfigItem2(Execute := Done1, sNetId := sNetId, nEtherCATSlaveAddr := nSlaveAddr, Slot_Addr := 1, RunModule:=0, LBusState:=LBusState1001,
30 OperationMode := 1, SubmoduleType := 164002, SubmoduleSize := 164001, SubmoduleNumber := 2, SerialPortNumber := 0,
31 xDone:=Done2, xBusy:=Busy2, xError:=Error2, xErrorID:=ErrorID2);
32
33 Set_Comm_ConfigItem3(Execute := Done2, sNetId := sNetId, nEtherCATSlaveAddr := nSlaveAddr, Slot_Addr := 1, RunModule:=0, LBusState:=LBusState1001,
34 OperationMode := 2, SubmoduleType := 164003, SubmoduleSize := 164001, SubmoduleNumber := 3, SerialPortNumber := 0,
35 xDone:=Done3, xBusy:=Busy3, xError:=Error3, xErrorID:=ErrorID3);
36
37 Set_Comm_ConfigItem4(Execute := Done3, sNetId := sNetId, nEtherCATSlaveAddr := nSlaveAddr, Slot_Addr := 1, RunModule:=0, LBusState:=LBusState1001,
38 OperationMode := 1, SubmoduleType := 164002, SubmoduleSize := 164001, SubmoduleNumber := 4, SerialPortNumber := 0,
39 xDone:=Done4, xBusy:=Busy4, xError:=Error4, xErrorID:=ErrorID4);
40
41 Set_Comm_ConfigItem5(Execute := Done4, sNetId := sNetId, nEtherCATSlaveAddr := nSlaveAddr, Slot_Addr := 1, RunModule:=0, LBusState:=LBusState1001,
42 OperationMode := 2, SubmoduleType := 164005, SubmoduleSize := 164001, SubmoduleNumber := 5, SerialPortNumber := 0,
43 xDone:=Done5, xBusy:=Busy5, xError:=Error5, xErrorID:=ErrorID5);
44
45 Set_Comm_ConfigItem6(Execute := Done5, sNetId := sNetId, nEtherCATSlaveAddr := nSlaveAddr, Slot_Addr := 1, RunModule:=0, LBusState:=LBusState1001,
46 OperationMode := 1, SubmoduleType := 164001, SubmoduleSize := 164001, SubmoduleNumber := 6, SerialPortNumber := 0,
47 xDone:=Done6, xBusy:=Busy6, xError:=Error6, xErrorID:=ErrorID6);
48
49 Set_Comm_ConfigItem7(Execute := Done6, sNetId := sNetId, nEtherCATSlaveAddr := nSlaveAddr, Slot_Addr := 1, RunModule:=0, LBusState:=LBusState1001,
50 OperationMode := 1, SubmoduleType := 164002, SubmoduleSize := 164001, SubmoduleNumber := 7, SerialPortNumber := 0,
51 xDone:=Done7, xBusy:=Busy7, xError:=Error7, xErrorID:=ErrorID7);
52
53 Set_Comm_ConfigItem8(Execute := Done7, sNetId := sNetId, nEtherCATSlaveAddr := nSlaveAddr, Slot_Addr := 2, RunModule:=0, LBusState:=LBusState1001,
54 OperationMode := 1, SubmoduleType := 164003, SubmoduleSize := 164001, SubmoduleNumber := 1, SerialPortNumber := 0,
55 xDone:=Done8, xBusy:=Busy8, xError:=Error8, xErrorID:=ErrorID8);
56
57 Set_Comm_ConfigItem9(Execute:=Done8, sNetId := sNetId, nEtherCATSlaveAddr := nSlaveAddr, Slot_Addr:=0, RunModule:=0, LBusState:=LBusState1001,
58 OperationMode:=0, SubmoduleType:=164001, SubmoduleSize:=164010, SubmoduleNumber:=2, SerialPortNumber:=1,
59 SlaveID:=1, StartAddress:=0, DataLength:=10, NumberOfRetransmissions:=1, ConfigurationItemCycleTime:= 1000,
60 xDone:=Done9, xBusy:=Busy9, xError:=Error9, xErrorID:=ErrorID9);
61
62 Set_Comm_ConfigItem10(Execute:=Done9, sNetId := sNetId, nEtherCATSlaveAddr := nSlaveAddr, Slot_Addr:=0, RunModule:=0, LBusState:=LBusState1001,
63 OperationMode:=0, SubmoduleType:=164002, SubmoduleSize:=164001, SubmoduleNumber:=3, SerialPortNumber:=1,
64 SlaveID:=1, StartAddress:=0, DataLength:=8, NumberOfRetransmissions:=1, ConfigurationItemCycleTime:= 1000,
65 xDone:=Done10, xBusy:=Busy10, xError:=Error10, xErrorID:=ErrorID10);
66
67 Set_Comm_ConfigItem11(Execute:=Done10, sNetId := sNetId, nEtherCATSlaveAddr := nSlaveAddr, Slot_Addr:=0, RunModule:=0, LBusState:=LBusState1001,
68 OperationMode:=0, SubmoduleType:=164003, SubmoduleSize:=164001, SubmoduleNumber:=4, SerialPortNumber:=1,
69 SlaveID:=1, StartAddress:=0, DataLength:=16, NumberOfRetransmissions:=1, ConfigurationItemCycleTime:= 1000,
70 xDone:=Done11, xBusy:=Busy11, xError:=Error11, xErrorID:=ErrorID11);
71
72 Set_Comm_ConfigItem12(Execute:=Done11, sNetId := sNetId, nEtherCATSlaveAddr := nSlaveAddr, Slot_Addr:=0, RunModule:=0, LBusState:=LBusState1001,
73 OperationMode:=0, SubmoduleType:=164004, SubmoduleSize:=164005, SubmoduleNumber:=5, SerialPortNumber:=1,
74 SlaveID:=1, StartAddress:=0, DataLength:=5, NumberOfRetransmissions:=1, ConfigurationItemCycleTime:= 1000,
75 xDone:=Done12, xBusy:=Busy12, xError:=Error12, xErrorID:=ErrorID12);
76
77 Set_Comm_ConfigItem13(Execute:=Done12, sNetId := sNetId, nEtherCATSlaveAddr := nSlaveAddr, Slot_Addr:=0, RunModule:=0, LBusState:=LBusState1001,
78 OperationMode:=0, SubmoduleType:=164005, SubmoduleSize:=164001, SubmoduleNumber:=6, SerialPortNumber:=1,
79 SlaveID:=1, StartAddress:=1000, DataLength:=8, NumberOfRetransmissions:=1, ConfigurationItemCycleTime:= 1000,
80 xDone:=Done13, xBusy:=Busy13, xError:=Error13, xErrorID:=ErrorID13);
81
82 Set_Comm_ConfigItem14(Execute:=Done13, sNetId := sNetId, nEtherCATSlaveAddr := nSlaveAddr, Slot_Addr:=0, RunModule:=1, LBusState:=LBusState1001,
83 OperationMode:=0, SubmoduleType:=164010, SubmoduleSize:=164002, SubmoduleNumber:=7, SerialPortNumber:=1,
84 SlaveID:=1, StartAddress:=1000, DataLength:=0, NumberOfRetransmissions:=1, ConfigurationItemCycleTime:= 1000,
85 xDone:=Done14, xBusy:=Busy14, xError:=Error14, xErrorID:=ErrorID14);

```

Note

- As shown in the example: When multiple function blocks are called, they must be used sequentially and connected end to end. They cannot be used in parallel or triggered simultaneously.
- When the module operates as a slave, if multiple submodules of the same type are added and the starting addresses of the submodules are identical, read and write operations from the master will only take effect on the first submodule that meets the conditions.

- Install the library file for Omron PLCs.
 - a. In the top menu bar, select "Project > Library > Show Index", as shown in the figure below.

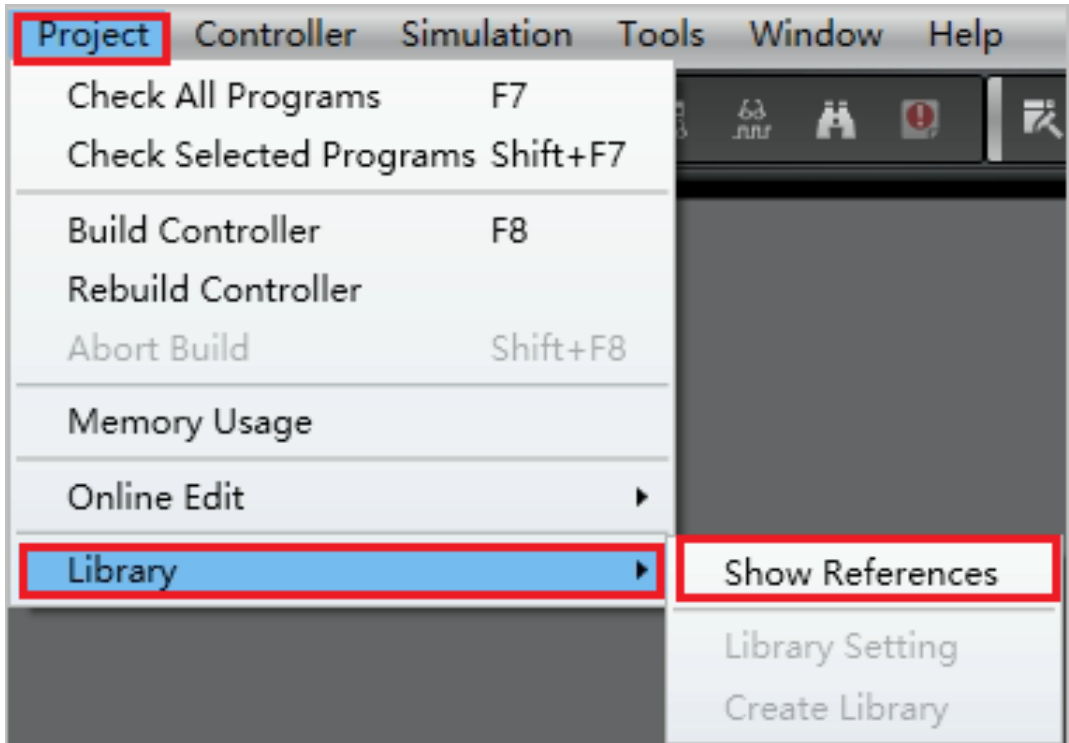

b. In the "Library Index" dialog box, click , as shown in the figure below.

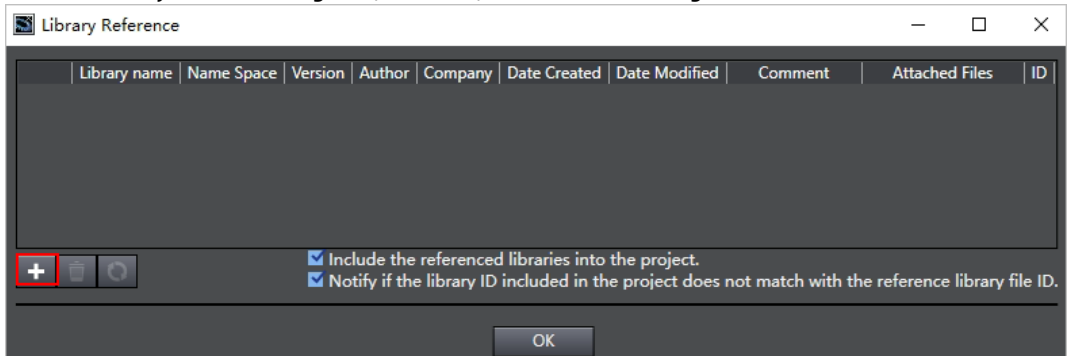

c. Select the library file and click "Open", as shown in the figure below.

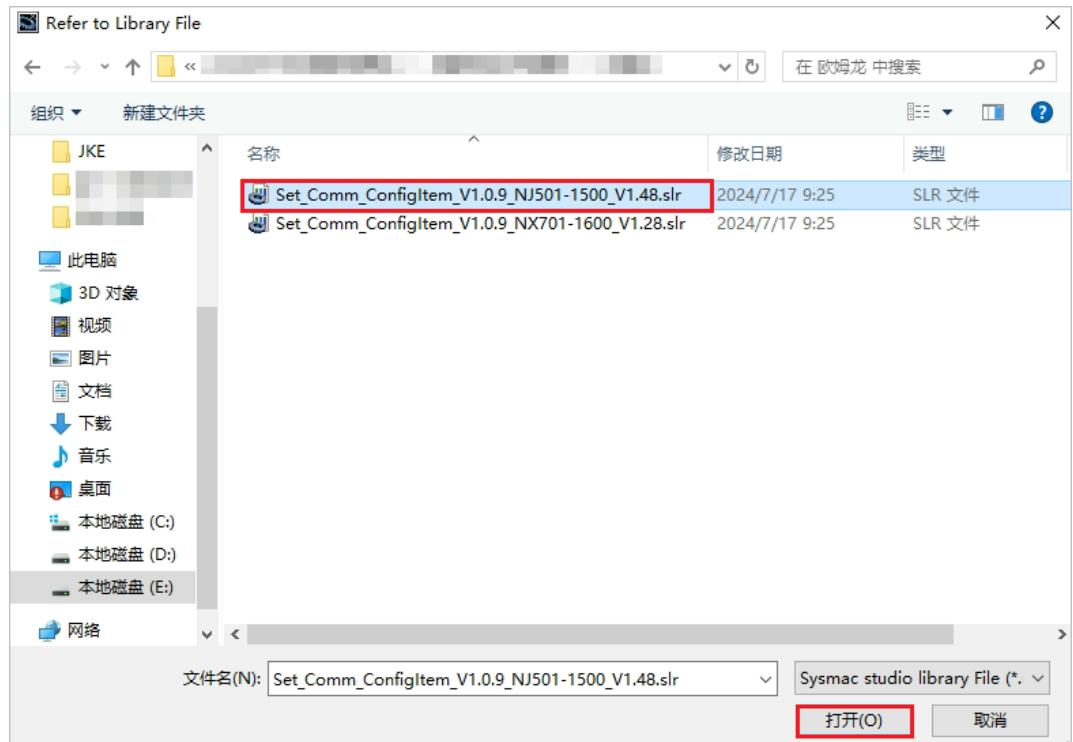

d. After importing the library file successfully, click "OK", as shown in the figure below.

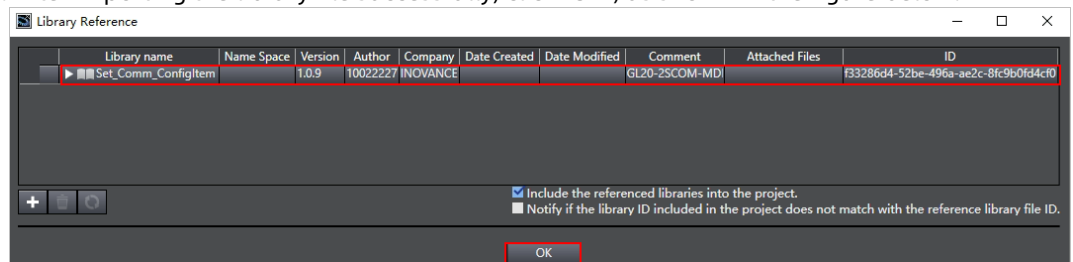

The imported "Set_Comm_ConfigItem" function block is displayed in the toolbox, as shown in the figure below.

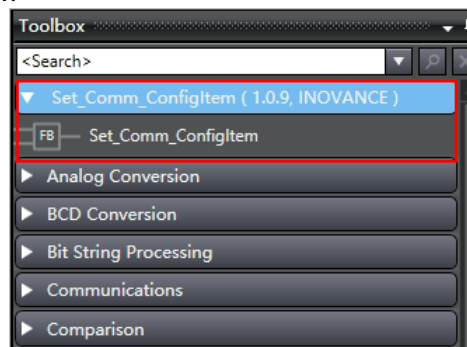

2. Configure startup parameters for serial port 0/1

- The parameter configuration for serial port 0 is described in the table below.

Index	Sub index	Parameter	Subparameter	Description	Bit	Data type	Configuration value range	Sub parameter default value	Parameter default value
0x8000	0	-	-	-	-	-	-	-	-
	1	COM0 (M/S/F): Mode/BaudRate	M/S/F: Modbus Mode	Operation mode	bit0 to bit1	UINT	<ul style="list-style-type: none"> • 0: Modbus master • 1: Modbus slave • 2: Free protocol 	0	0x0400
			M/S/F: Standard BaudRate	Baud rate	bit8 to bit11		<ul style="list-style-type: none"> • 3: 4800 • 4: 9600 • 5: 19200 • 6: 38400 • 7: 57400 • 8: 115200 	4	
	2	COM0 (M/S/F): Serial Port Settings	M/S/F: Data Bit	Data bit	bit0		<ul style="list-style-type: none"> • 0: 7 bits • 1: 8 bits 	1	0x0209
			M/S/F: Parity Bit	Parity bit	bit1 to bit2		<ul style="list-style-type: none"> • 0: No parity • 1: Odd parity • 2: Even parity 	0	
			M/S/F: Stop Bit	Stop bit	bit3 to bit4		<ul style="list-style-type: none"> • 1: 1 bit • 2: 2 bits 	1	
			M/S: Serial Mode	Serial mode	bit5		Not available yet. Default: RTU	0	
			F: FreePort-Coefficient	Free-Port-coefficient	bit8 to bit15		0 to 255	2	

Index	Subindex	Parameter	Subparameter	Description	Bit	Data type	Configuration value range	Subparameter default value	Parameter default value		
0x8000	3	COM0 (M/S/F): Char Pitch (Unit is 0.1 characters)	M/S/F: Char Pitch (Unit is 0.1 characters)	Character pitch (unit: 0.1 characters)	-	UINT	35 to 10000	35	0x0023		
	4	COM0 (M/F): Response Timeout	M/F: Response Timeout	Response timeout	-		10 to 65535	1000	0x03E8		
	5	COM0 (M): Delay Between Polls	M/F: Delay Between Polls	Polling delay	-		0 to 65535	100	0x0064		
	6		COM0 (M/S): Master Control And Slave ID	M: Read Timeout Action	Action upon read timeout		bit0	<ul style="list-style-type: none"> • 0: Retain the last input value • 1: Clear 	0	0x0110	
				M: Output Mode	Data output mode		bit1		<ul style="list-style-type: none"> Not available yet. Default: Polling mode 		0
				M: Module Control	Module control enable		bit2		<ul style="list-style-type: none"> • 0: Disable • 1: Enable 		0
				M: Module Control Mode	Module control method		bit3		<ul style="list-style-type: none"> • 0: Level triggered (active continuously) • 1: Rising edge triggered (single shot) 		0
			COM0 (M/S): Master Control And Slave ID	Reserve	Reserved	bit4 to bit7	UINT	1	1	0x0110	
				S: Slave ID	Slave ID	bit8 to bit15		1 to 247	1		
	7		COM0 (S): Response Delay	S: Response Delay	Response delay time	-		0 to 65535	50	0x0032	

- The description of COM0(M/S/F): Serial Port Settings and their corresponding values are shown in the following table.

Value (hexadecimal)	Value (decimal)	Description	Value (hexadecimal)	Value (decimal)	Description	Value (hexadecimal)	Value (decimal)	Description
0x0209	521	8N1	0x020B	523	8O1	0x020D	525	8E1
0x0211	529	8N2	0x0213	531	8O2	0x0215	533	8E2
-	-	-	0x020A	522	7O1	0x020C	524	7E1
-	-	-	0x0212	530	7O2	0x0214	532	7E2

Note

In "Value (Hexadecimal)", "02" represents the FreePort coefficient. In general, use the default value 02. If the module operates as a master or in free protocol mode and needs to immediately pull the RTS pin low to receive data from the slave after transmission, set this value to 0.

- The description of COM0(M/S): Master Control And Slave ID and their corresponding values are shown in the following table.

Value (hexadecimal)	Description	Value (hexadecimal)	Description
0xID14	Hold enable, level triggered	0xID15	Clear enable, level triggered
0xID1C	Hold enable, rising edge triggered	0xID1D	Clear enable, rising edge triggered
0xID10	Hold disable	0xID11	Clear disable

The "ID" in "Value" represents the slave ID. When the module operates as a master, the slave ID is unavailable and can be set to 0x01. When the module operates as a slave, the slave ID can be set according to actual conditions.

- The description of serial port 1 configuration parameters is the same as that of serial port 0 configuration parameters. The serial port 0 is configured for subindex 1 to 7, while the serial port 1 is configured for subindex 8 to 14.
- Modify serial port 0/1 configuration parameters online for Beckhoff PLCs and Omron PLCs.
 - Modify serial port 0/1 configuration parameters for Beckhoff PLCs.
 - Example: Modify the operation mode of serial port 1 for Module1 (GL20-2S485-MDB). The default value of current serial port 1 is 0x0400, indicating Modbus master with a baud rate of 9600 bps. To change its operation mode to free protocol, follow the sequence shown in the figure below.

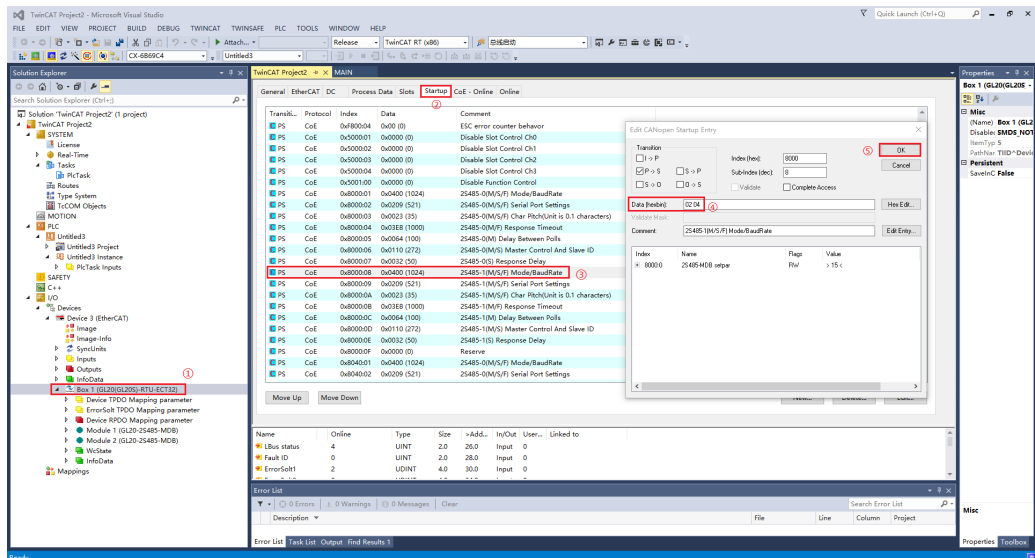

Step ④: Data 0x0402 is written as follows. 0x0402 indicates free protocol and a baud rate of 9600 bps.

b. After modification, the configuration has been changed. Verify that the changed value is correct, as shown in the figure below.

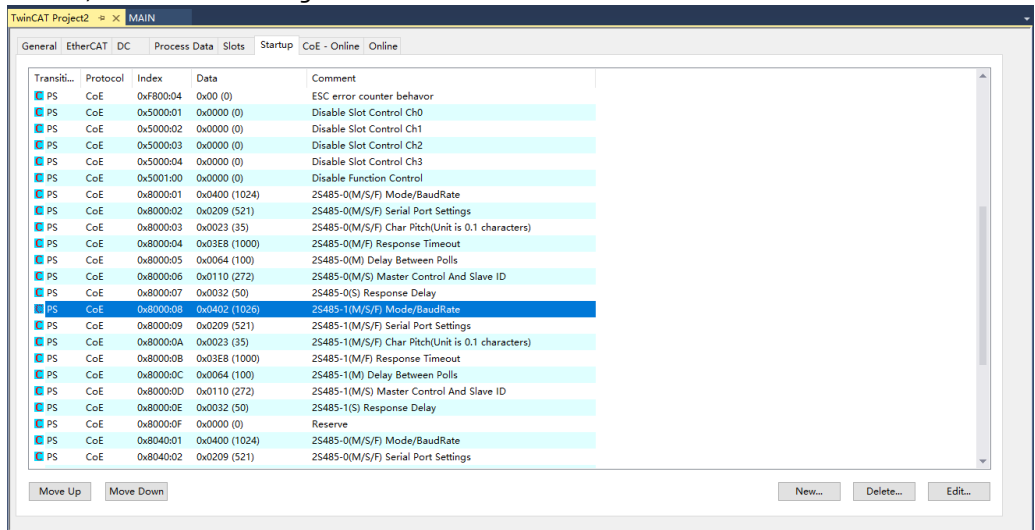

c. After completing all required configuration modifications and confirming the values are correct, re-click "Activate Configuration" for the changes to take effect. Use online CoE to check whether the serial port 0/1 configuration has been successfully updated, as shown in the figure below.

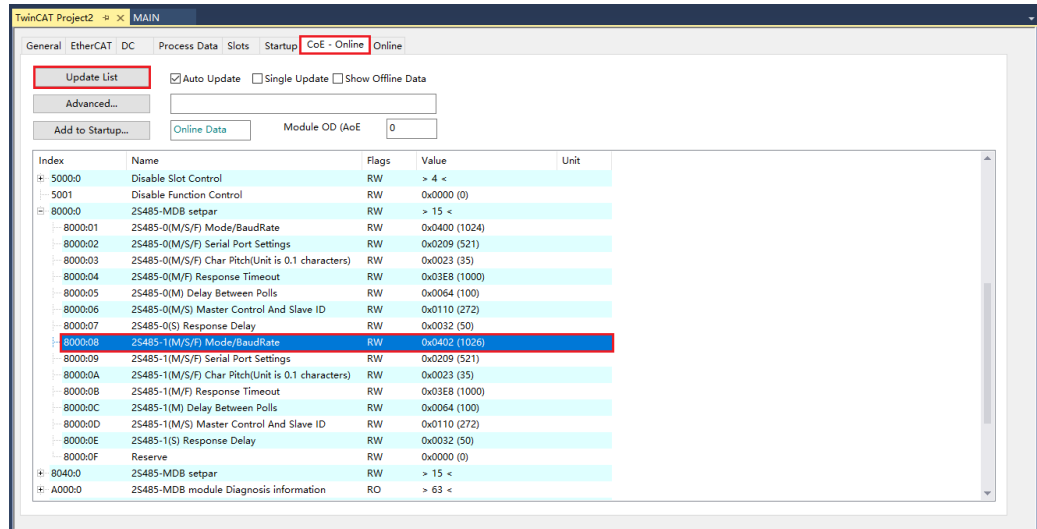

- Modify serial port 0/1 configuration parameters for Omron PLCs.
 - a. Double-click the "GL20-RTU-ECT32" communication interface module, and then click the "GL20-2S485-MDB" module, and edit the initialization parameter settings, as shown in the figure below.

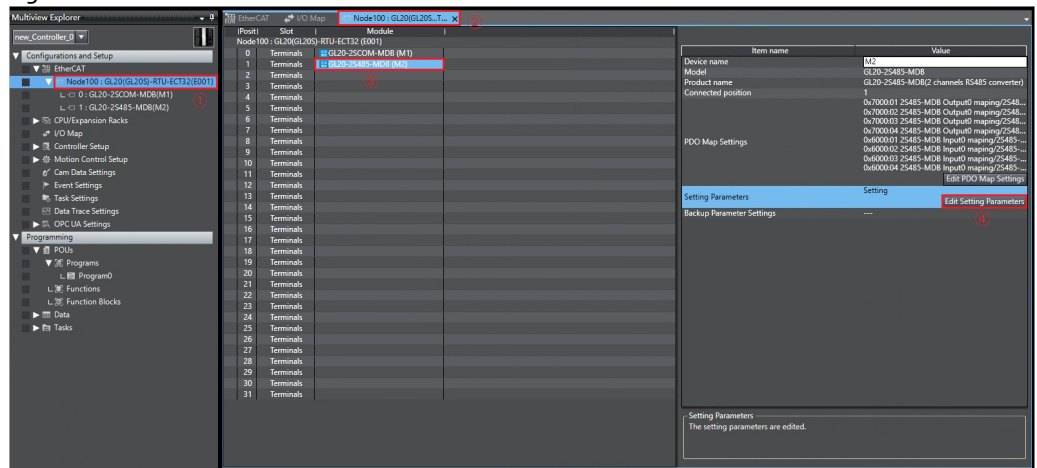

The default values are shown in the following figure.

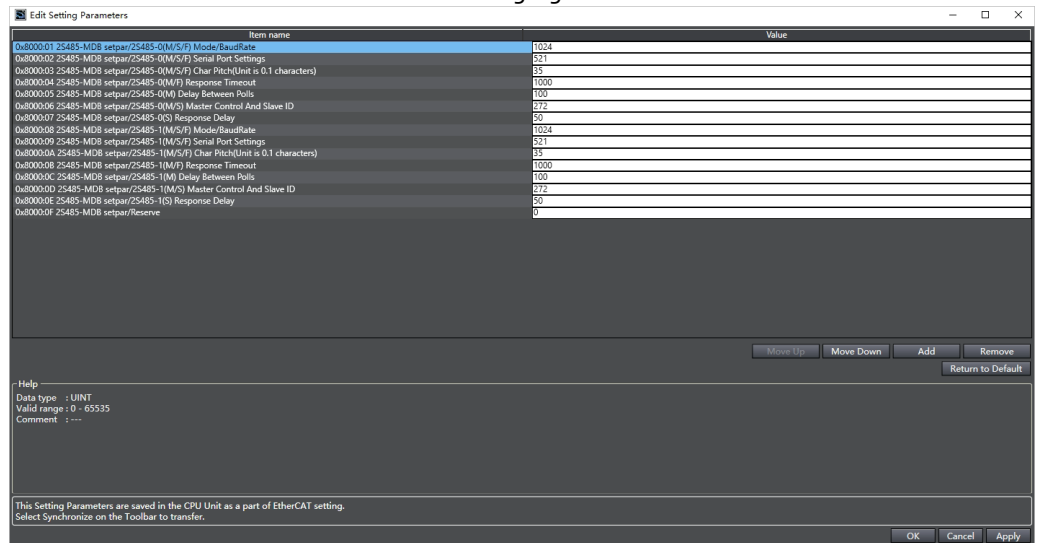

- b. Offline modification instruction for serial port 0/1 configuration parameters.

Modify serial port 0/1 to free protocol and set the baud rate to 9600 bps, and then click OK, as shown in the figure below.

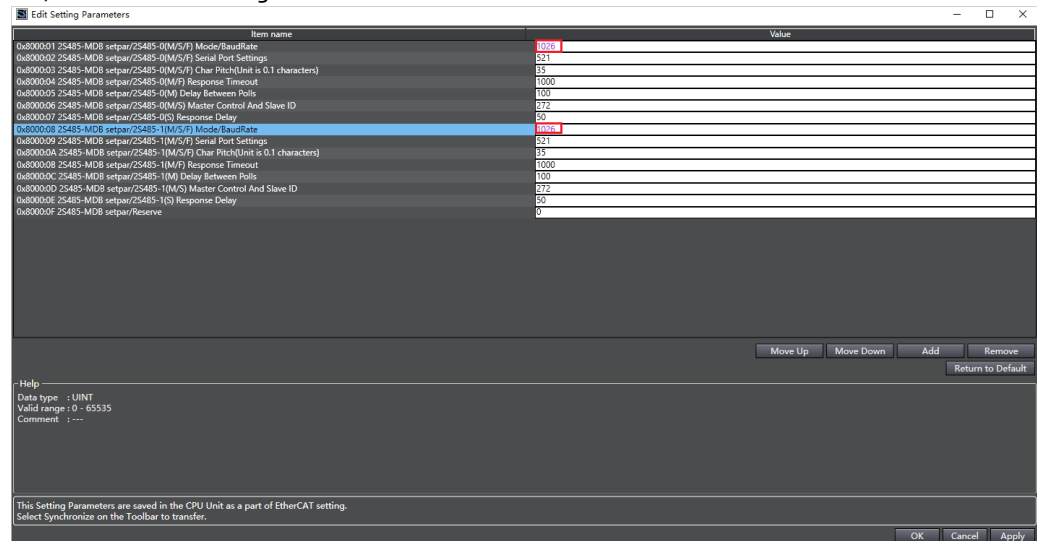

c. After the PLC is online, the program will be synchronized to the controller, and the modified parameters will take effect.

3. Configure Modbus-RTU protocol and free protocol commands.

- Configure Modbus-RTU protocol and free protocol commands for Beckhoff PLCs.
 - Configure Modbus commands for Beckhoff PLCs.
 - a. Right-click "PLC" in the project tree on the left side of the interface, select "Add New Item" to add a new item, as shown in the figure below.

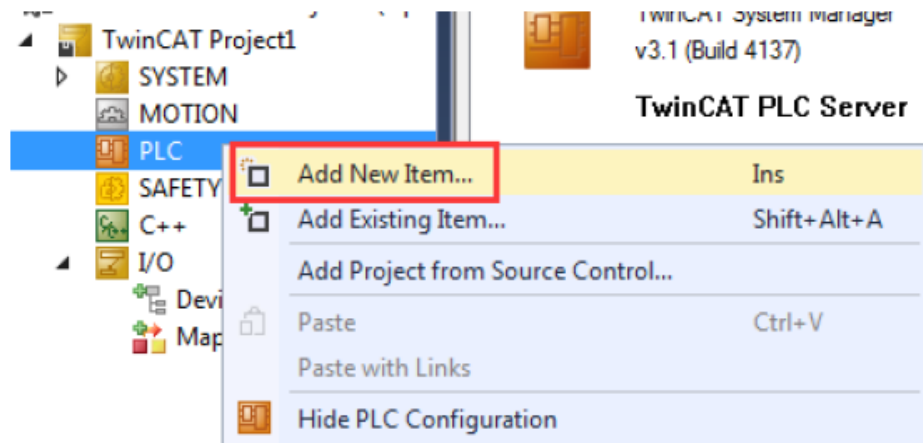

b. Select "Standard PLC Project" and change the project name to an English name, as shown in the figure below.

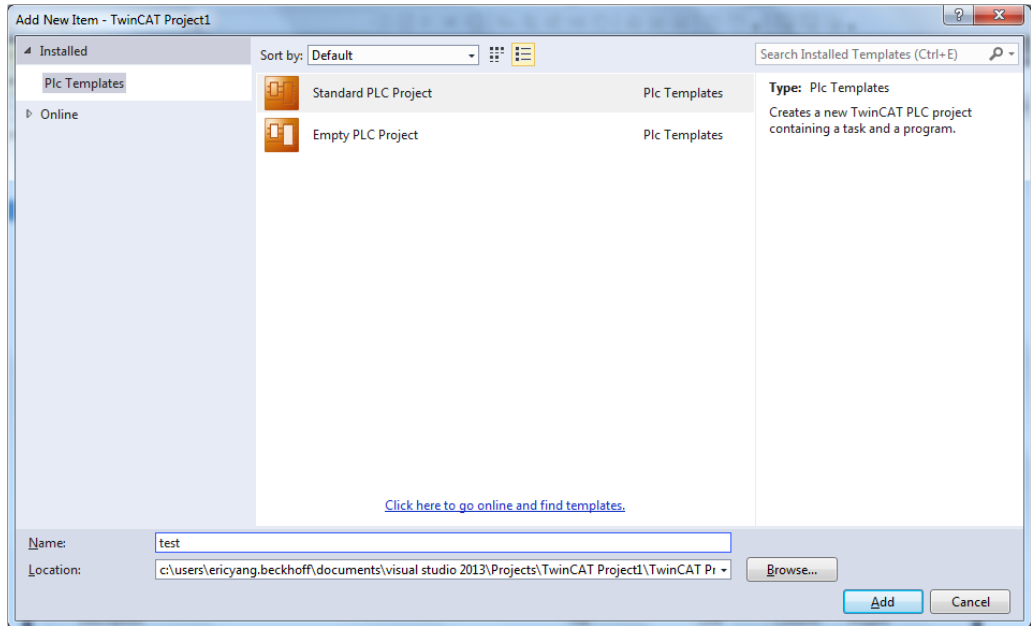

c. In the project tree, select "POUs > MAIN (PRG)", and edit the program, as shown in the figure below.

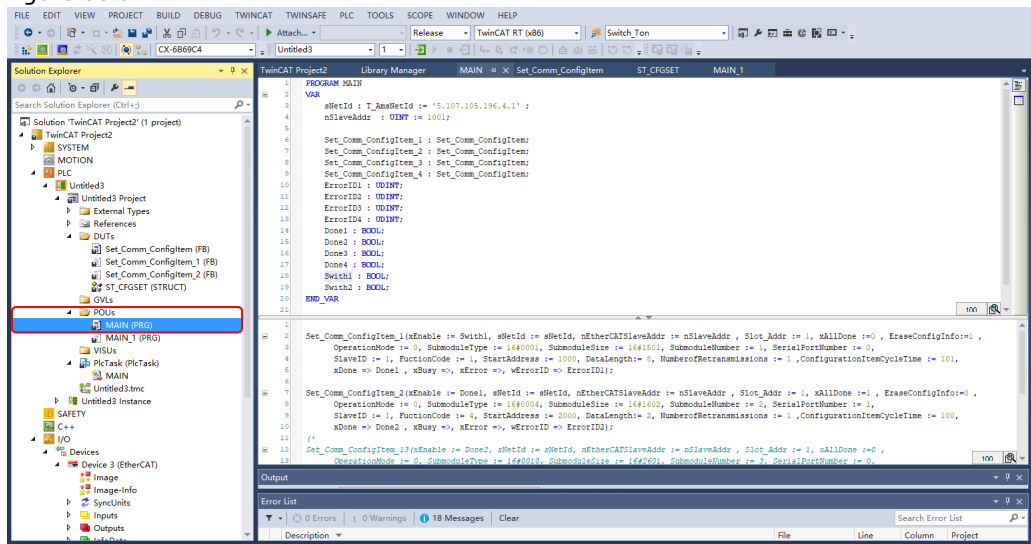

d. Right-click the new project and select "Build", as shown in the figure below.

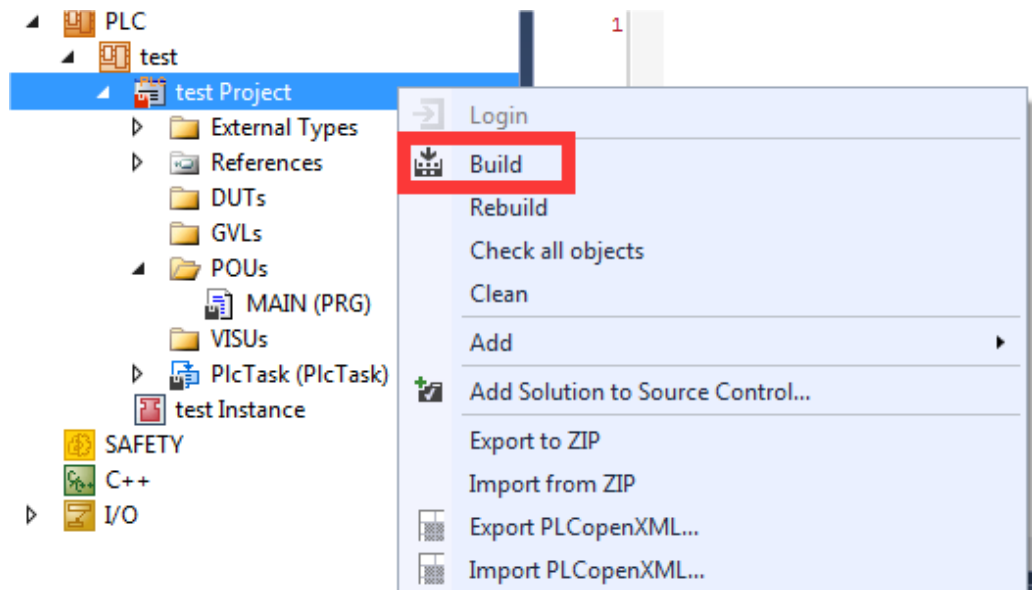

- e. The system automatically compiles the code. If no errors are found in the code, a success message will be displayed in the "Output" message bar, and the input/output variable connections are generated in "test Instance", as shown in the figure below.

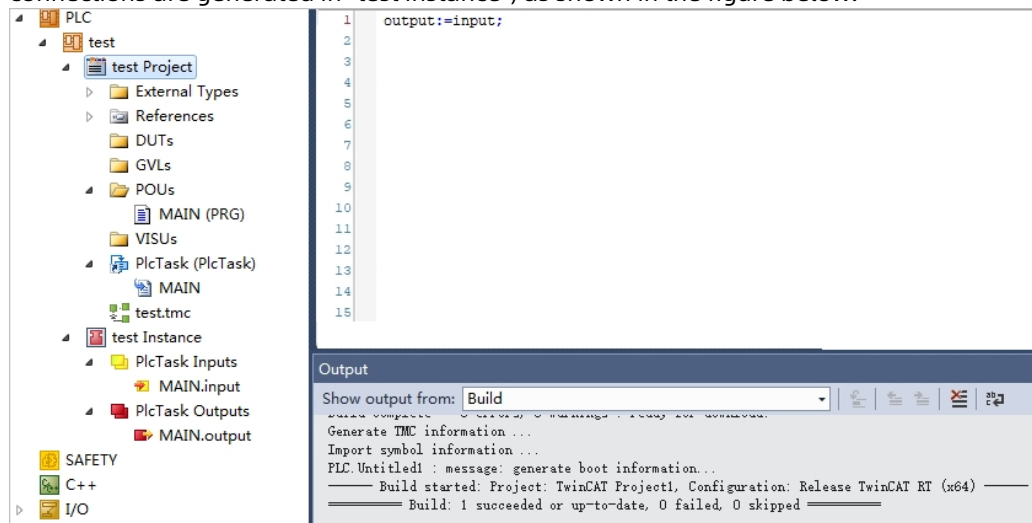

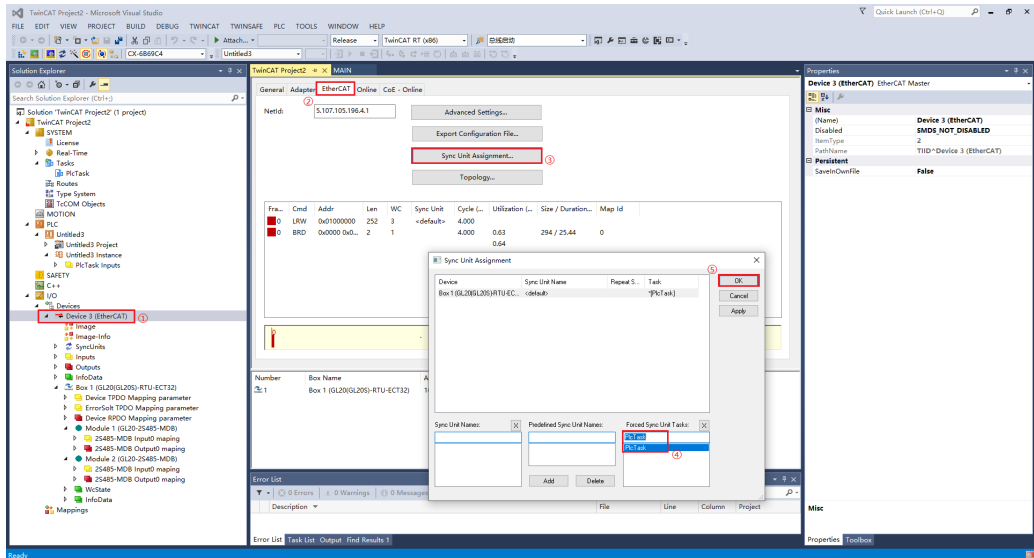

- f. After successful compilation, assign the EtherCAT master task.

After each I/O device rescan, perform task allocation. (Follow the numbered sequence shown in the figure below)

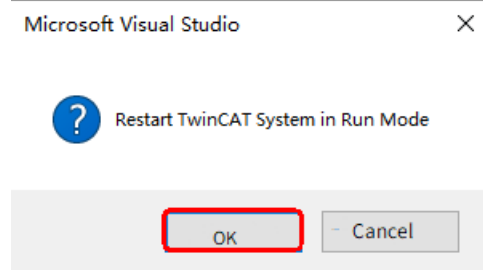
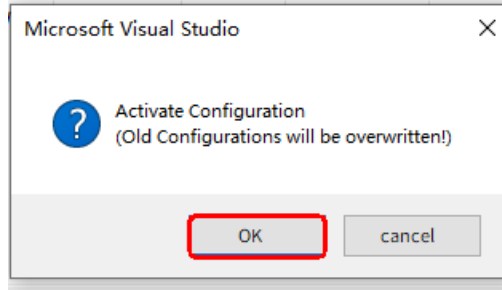
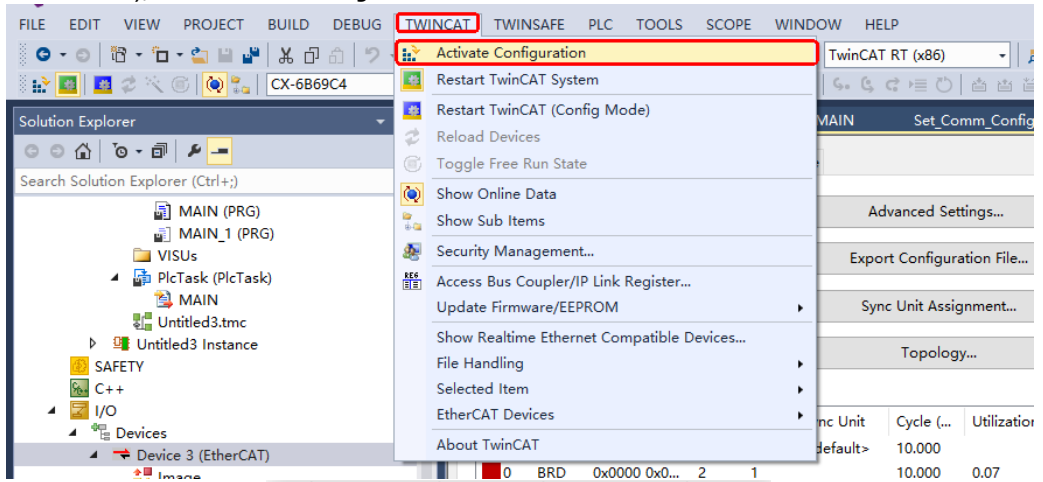

g. Select "TWINCAT > Activate Configuration", and click "OK" in the pop-up dialog box. The GL20-RTU-ECT32 communication interface module is in the running state (RUN light remains on), as shown in the figure below.



h. Click  on the toolbar to log in to the PLC host, as shown below.

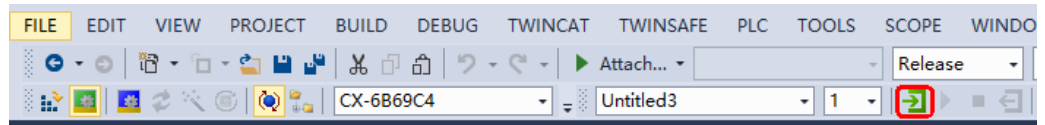

i. After successful login, click  on the toolbar to start the program, as shown in the figure below.

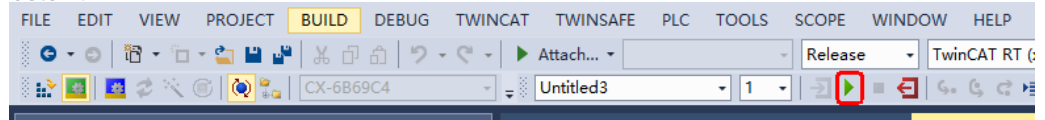

j. The program is running normally, as shown in the figure below.

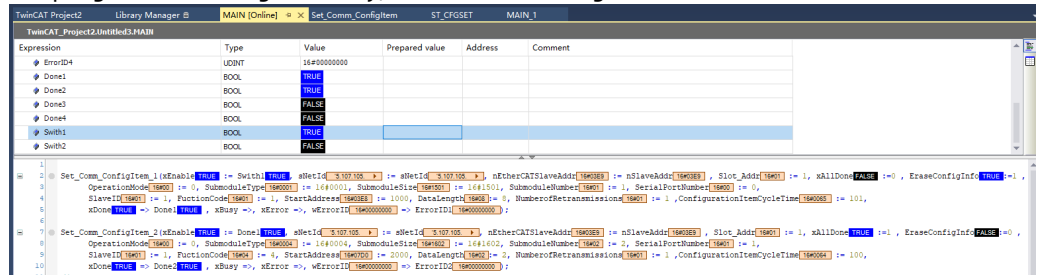

Note

All function block "xDone" are "TRUE", and "wErrorID" is zero. The PR light of the module changes from flashing to steady ON, indicating that the configuration data has been successfully sent, and the module is running normally.

k. Modify the input and output process data object (PDO) size.

The process data objects (PDO) are mapped in 4 sets of 120 bytes for user selection. Due to limitations in the EtherCAT PDO transmission mechanism, only 480 bytes are currently allocated for data transmission and reception by communication modules. The maximum PDO byte count per module corresponding to the number of modules is shown in the following table.

Number of modules	Maximum PDO byte count per module
1	480
2	240
3	120
4	120

The default input and output process data are each 120 bytes, as shown in the figure below.

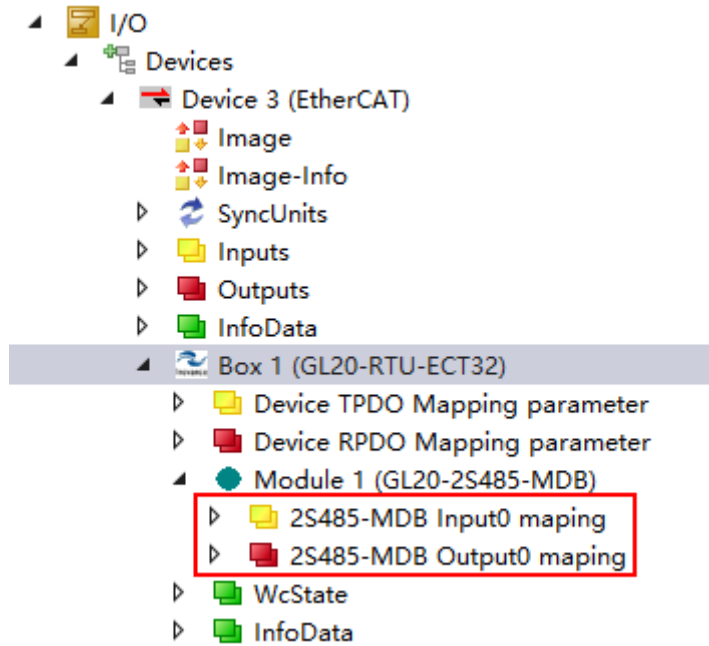

1). To increase output process data size: If the output process data exceeds 120 bytes, perform the operation in the numbered sequence shown in the figure. Select the options in "PDO Assignment (0x1C12):" to increase the output process data size, as shown in the figure below.

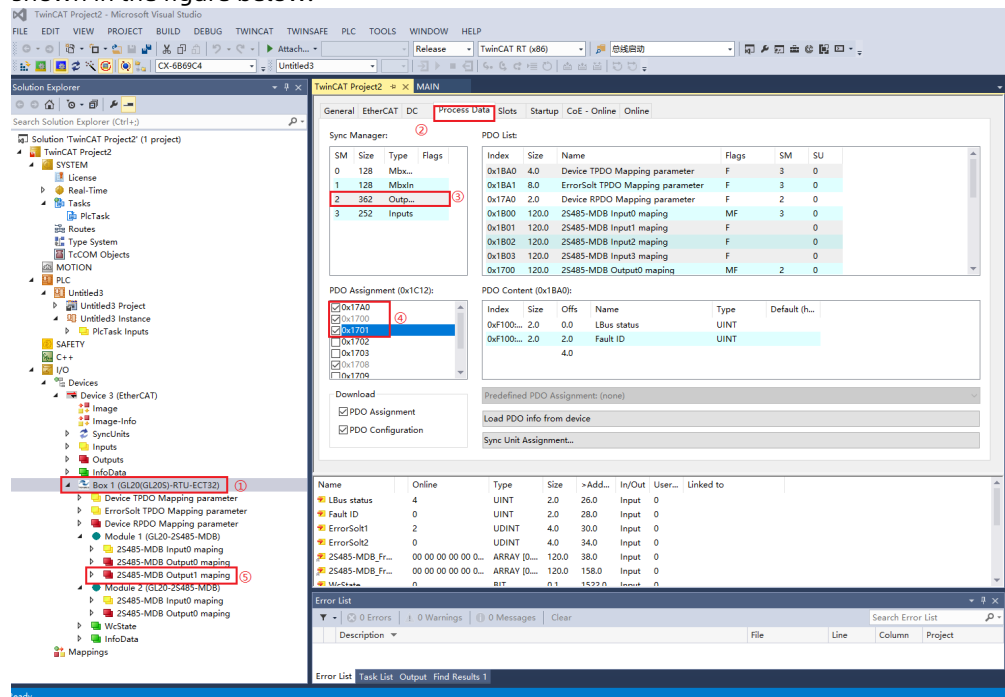

2). To increase input process data size, perform the operation in the numbered sequence shown in the figure. Select the options in "PDO Assignment (0x1C13):" to increase the input process data size, as shown in the figure below.

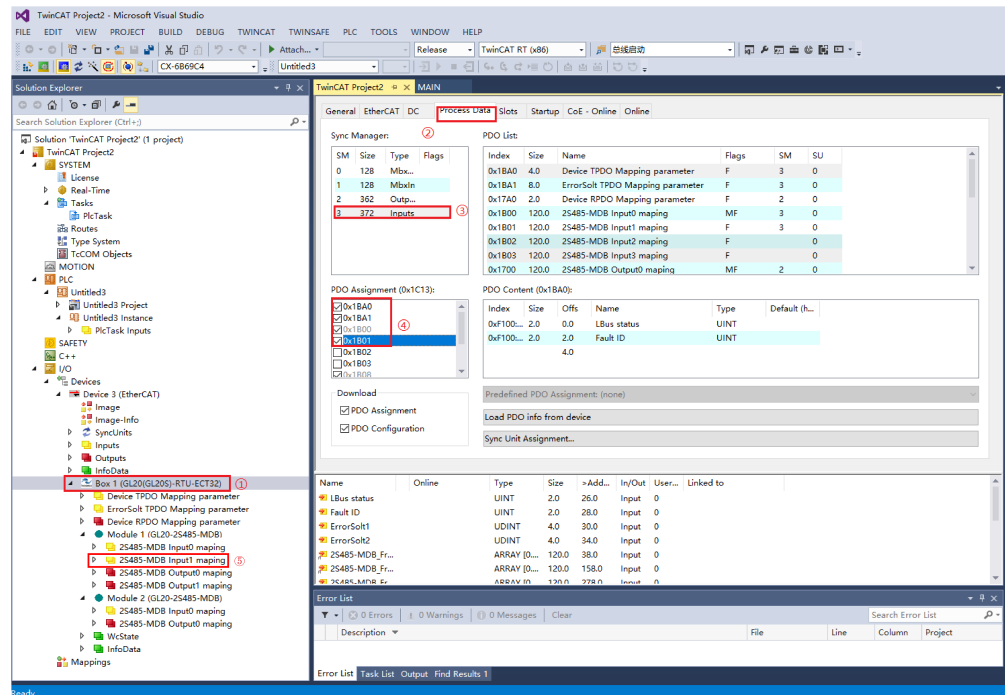

3). To increase or decrease process data size, you must re-click "Activate Configuration" for the changes to take effect.

- Configure free protocol commands for Beckhoff PLCs.
 - a. Take serial port 0 as an example, and set the free protocol communication mode to request-response mode. First, call the "F: Control Status Module" control and status submodule. Then, select the appropriate input/output data submodule according to the input/output data size (In this example, both input and output data submodule have a data size of 4 words, that is, 8 bytes), as shown in the figure below.

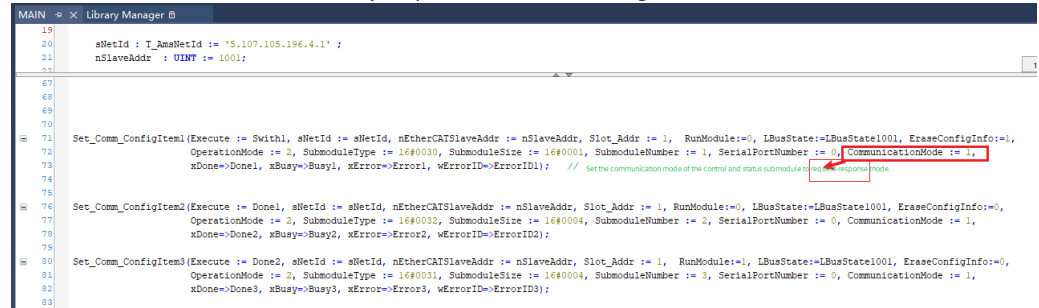

The description of each byte in the "F: Control Status Module" control and status submodule (4-byte status control output) is shown in the following table.

Byte	Bit	Description	Note
Byte 1	bit0	Trigger control word	Control word
	bit1	Completion reset	
	bit2	Parity error reset	
	bit3	Timeout error reset	
	bit4	Error counter reset	
	bit5	Receive counter reset	
	bit6	Received data reset	
Byte 2	Unsigned8	Reserve	Valid data length: compatible with GL20-RTU-ECT32 (476Byte) /GL20-RTU-PN (474Byte). Defaults to maximum value if this limit is exceeded.
Byte 3	Unsigned8	Transmit frame byte length (high byte)	
Byte 4	Unsigned8	Transmit frame byte length (low byte)	

b. The control output mapping for the "F:Control Status Module" control and status submodule is shown in the following figure (with the trigger control word enabled and the transmit frame byte length set to 8 bytes). Map the data to be output as shown in the following figure.

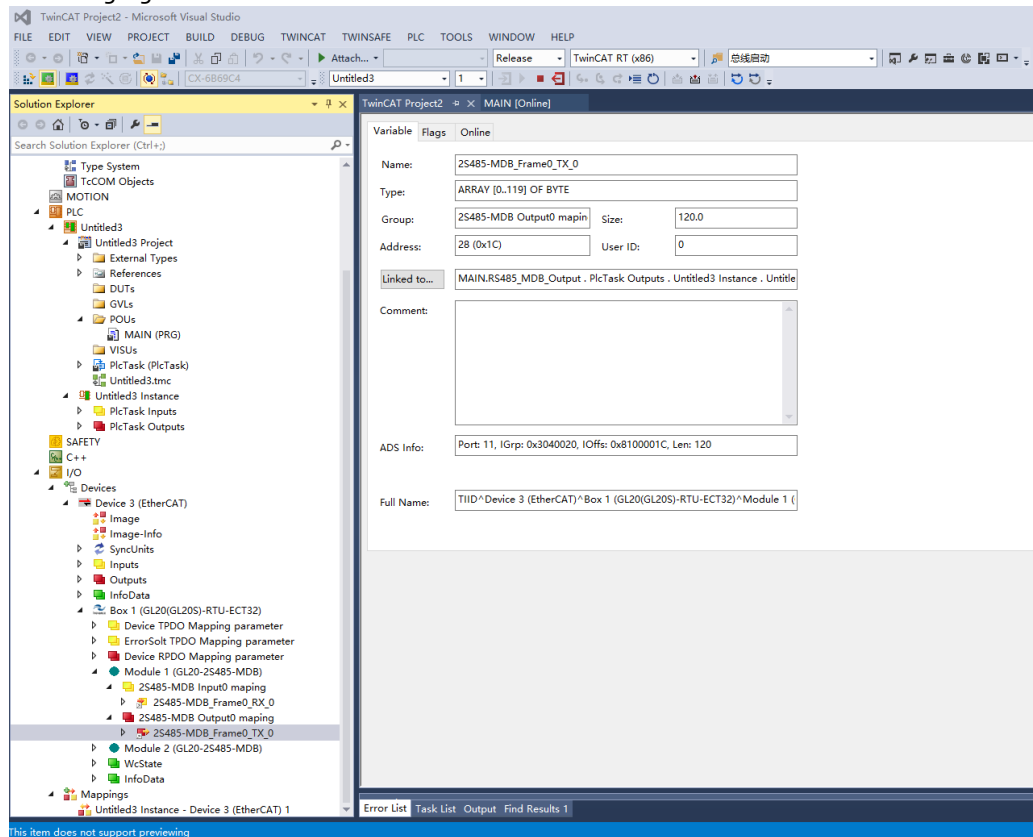

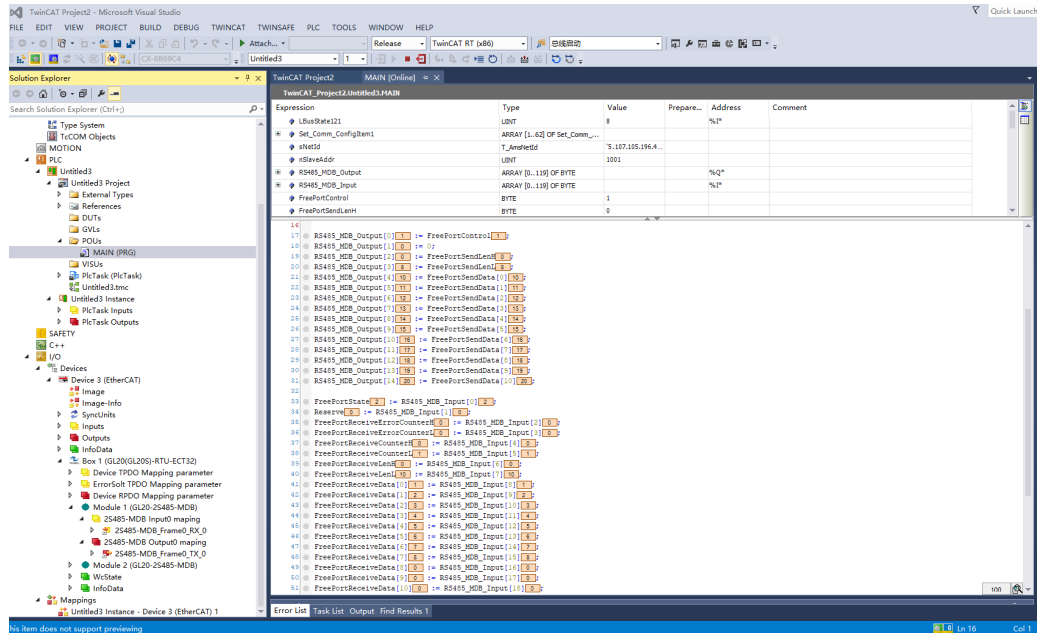

c. When the 2S485-MDB module detects a rising edge of the trigger control word, it transmits the 8-byte data from the output data area via the serial port, and manually simulates a 10-byte response data as an acknowledgment.

The description of each byte in the "F:Control Status Module" control and status submodule (8-byte status feedback input) is shown in the following table.

Byte	Bit	Description	Note
Byte 1	bit0	Busy status	Serial port status
	bit1	Communication completion flag	
	bit2	Parity error	
	bit3	Timeout error	
	bit4 to bit7	Reserve	
Byte 2	Unsigned8	Reserve	-
Byte 3	Unsigned8	Receive error frame count (high byte)	-
Byte 4	Unsigned8	Receive error frame count (low byte)	-
Byte 5	Unsigned8	Total received data frame count (high byte)	-
Byte 6	Unsigned8	Total received data frame count (low byte)	-
Byte 7	Unsigned8	Current receive frame byte length (high byte)	-
Byte 8	Unsigned8	Current receive frame byte length (low byte)	-

d. In the figure above, the first byte is 2, indicating communication completion. The receive error frame count is 0. The total received data frame count is 1, and the current receive frame byte length is 10 bytes. Since the input data submodule is set to 8 bytes, only the 8-byte response data are displayed, as shown in the figure below.

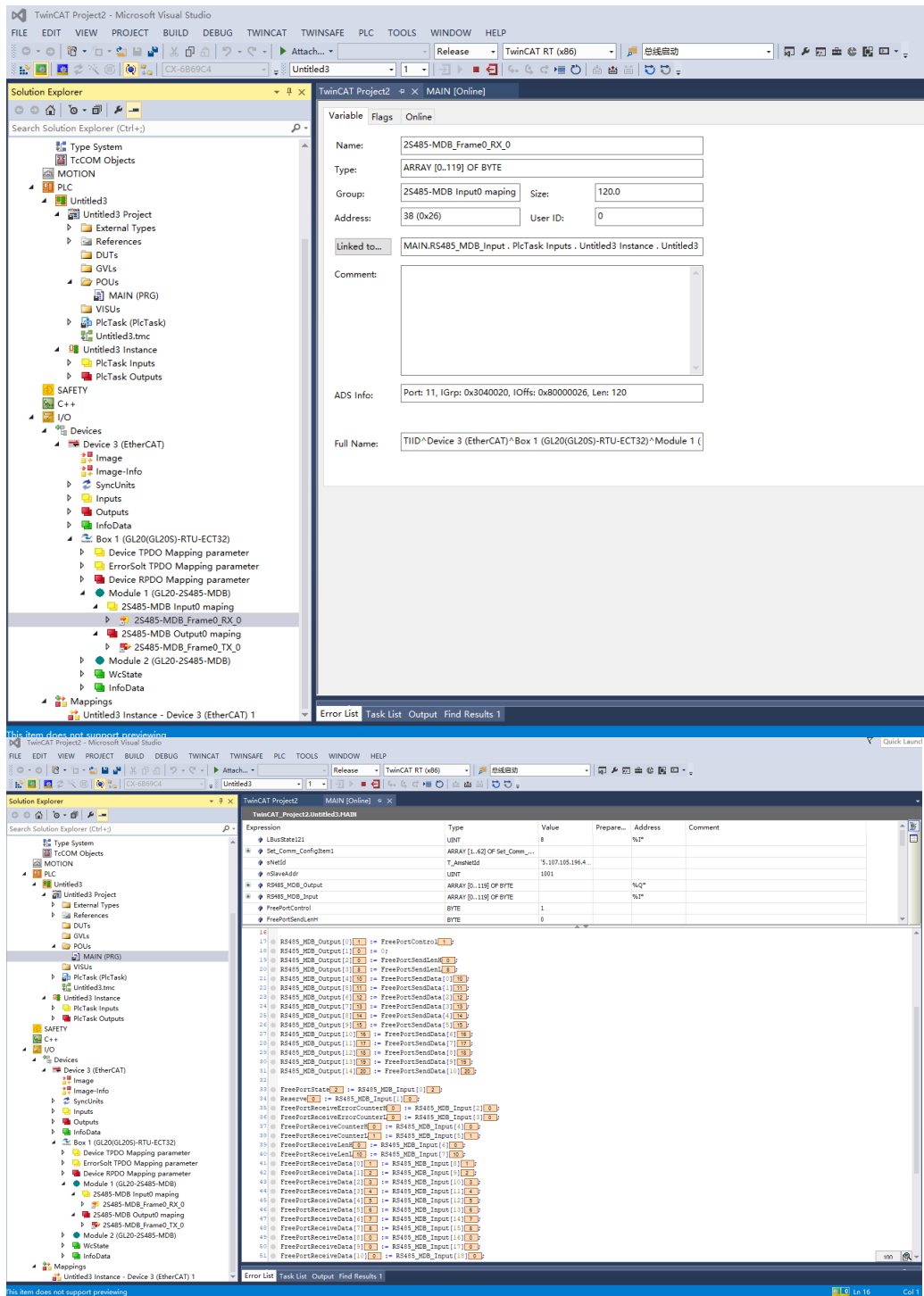

The status feedback of the "F:Control Status Module" control and status submodule under different scenarios is described as follows.

- Request-response mode: On the rising edge of the trigger control word, the triggered serial port sends data once. The serial port transmits data according to the configured transmit frame byte length. During transmission, the busy status bit is set to 1. The timing diagram is shown below.

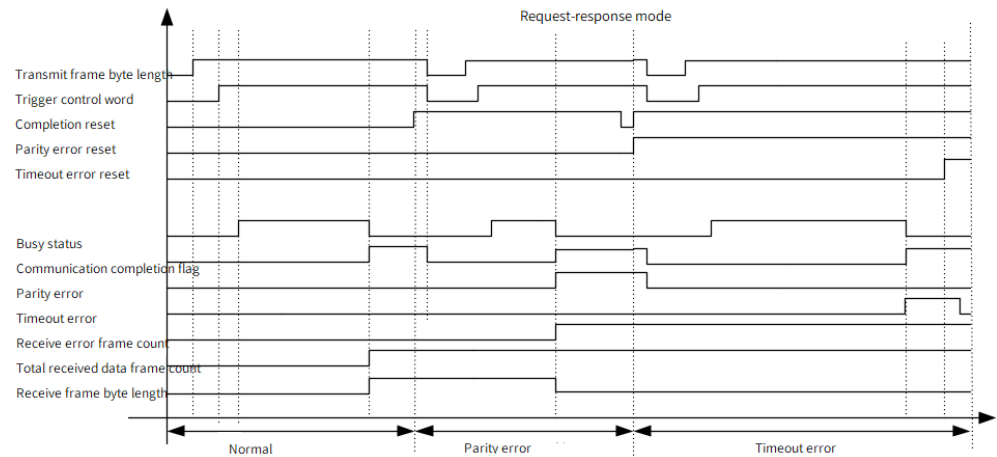

- ◇ Normal mode: If a response is received via the serial port within the timeout period, the busy status bit is cleared, the communication completion flag is set to 1, the total received data frame count is incremented by 1, and the current receive frame byte length is set to the actual received length.
- ◇ Parity error: If a response is received via the serial port within the timeout period but a parity error occurs, the busy status bit is cleared, the communication completion flag is set to 1, the parity error flag is set to 1, the receive error frame count is incremented by 1, and the current receive frame byte length is set to 0.
- ◇ Timeout error: If a response is received via the serial port within the timeout period, the busy status bit is cleared, the communication completion flag is set to 1, the timeout error is set to 1, the receive error frame count is incremented by 1, and the current receive frame byte length is set to 0.

- The timing diagram for the receive-only mode is shown below.

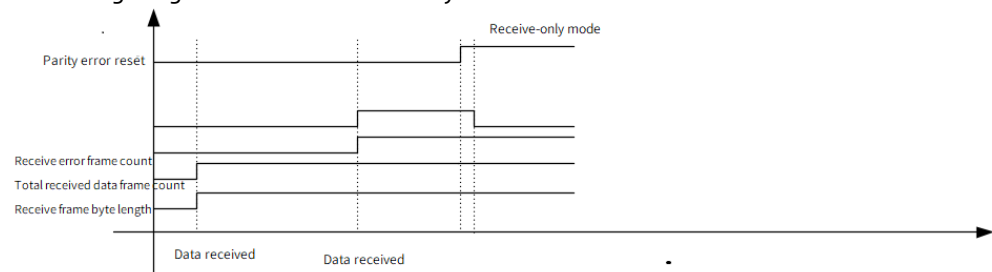

- ◇ When the module receives data, the total received frame count is incremented by 1, and the current receive frame byte length is set to the actual received length.
- ◇ When the module receives data but a parity error occurs, the parity error is set to 1, the receive error frame count is incremented by 1, the total received data frame count is incremented by 1, and the current receive frame byte length is set to the actual received length.

- The timing diagram for the transmit-only mode is shown below. On the rising edge of the trigger control word, the triggered serial port sends data once. The serial port transmits data according to the configured transmit frame byte length. During transmission, the busy status bit is set to 1.

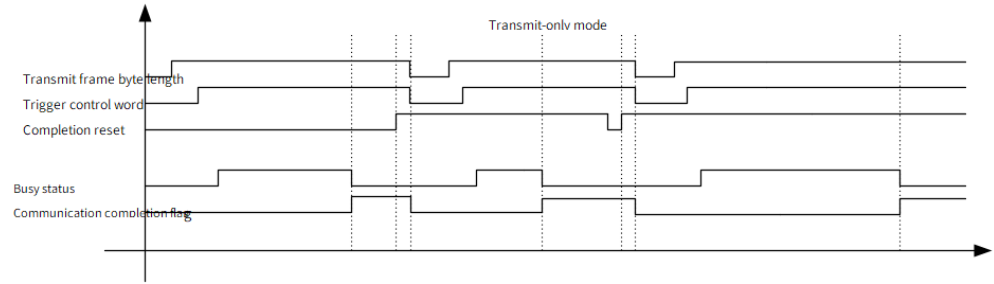

After the data transmission, the busy status bit is cleared, and the communication completion flag is set to 1.

- When the serial port status is cleared:
 - ◇ On the rising edge of the completion reset, the communication completion flag is cleared.
 - ◇ On the rising edge of the parity error reset, the parity error is cleared.
 - ◇ On the rising edge of the timeout error reset, the timeout error is cleared.
 - ◇ On the rising edge of the error counter reset, the receive error frame count is cleared.
 - ◇ On the rising edge of the receive counter reset, the total received data frame count is cleared.
 - ◇ On the rising edge of the received data reset, the current receive frame byte length is cleared.
- Configure Modbus-RTU protocol and free protocol commands for Omron PLCs.
 - Configure Modbus-RTU protocol commands for Omron PLCs.
 - a. The settings for Modbus master and slave variables are shown in the following figure.

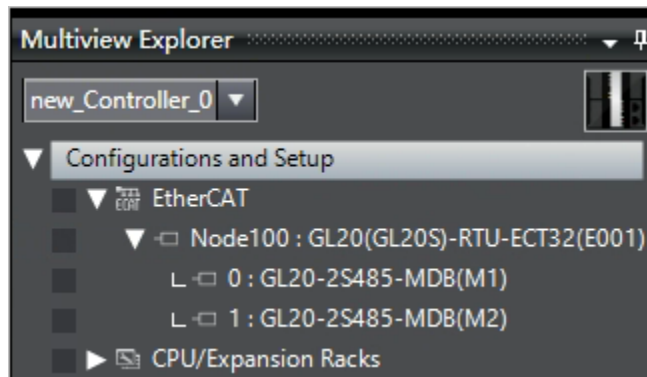

```

1
2
3 Set_Comm_ConfigItem1(Execute:=Swit1, Node_ID:=Nodeid1, Slot_Addr:=1, RunModule:=0, LBusState:=LBusState121, EraseConfigInfo:=1,
4   OperationMode:=0, SubmoduleType:=16#0001, SubmoduleSize:=16#0001, SubmoduleNumber:=1, SerialPortNumber:=0,
5   SlaveID:=1, StartAddress:=0, DataLength:=1, NumberOfRetransmissions:=1, ConfigurationItemCycleTime:=100,
6   xDone=>Done1, xBusy=>Busy1, xError=>Error1, wErrorID=>ErrorID1);
7
8 Set_Comm_ConfigItem2(Execute:=Done1, Node_ID:=Nodeid1, Slot_Addr:=1, RunModule:=0, LBusState:=LBusState121, EraseConfigInfo:=0,
9   OperationMode:=1, SubmoduleType:=16#0023, SubmoduleSize:=16#0001, SubmoduleNumber:=2, SerialPortNumber:=1, StartAddress:=0,
10  xDone=>Done2, xBusy=>Busy2, xError=>Error2, wErrorID=>ErrorID2);
11
12 Set_Comm_ConfigItem3(Execute:=Done2, Node_ID:=Nodeid1, Slot_Addr:=1, RunModule:=0, LBusState:=LBusState121, EraseConfigInfo:=0,
13   OperationMode:=1, SubmoduleType:=16#0024, SubmoduleSize:=16#0001, SubmoduleNumber:=3, SerialPortNumber:=1, StartAddress:=0,
14  xDone=>Done3, xBusy=>Busy3, xError=>Error3, wErrorID=>ErrorID3);
15
16 Set_Comm_ConfigItem4(Execute:=Done3, Node_ID:=Nodeid1, Slot_Addr:=1, RunModule:=0, LBusState:=LBusState121, EraseConfigInfo:=0,
17   OperationMode:=1, SubmoduleType:=16#0026, SubmoduleSize:=16#0001, SubmoduleNumber:=4, SerialPortNumber:=1, StartAddress:=0,
18  xDone=>Done4, xBusy=>Busy4, xError=>Error4, wErrorID=>ErrorID4);
19
20 Set_Comm_ConfigItem5(Execute:=Done4, Node_ID:=Nodeid1, Slot_Addr:=1, RunModule:=0, LBusState:=LBusState121, EraseConfigInfo:=0,
21   OperationMode:=1, SubmoduleType:=16#0025, SubmoduleSize:=16#0001, SubmoduleNumber:=5, SerialPortNumber:=1, StartAddress:=0,
22  xDone=>Done5, xBusy=>Busy5, xError=>Error5, wErrorID=>ErrorID5);
23
24 Set_Comm_ConfigItem6(Execute:=Done5, Node_ID:=Nodeid1, Slot_Addr:=1, RunModule:=0, LBusState:=LBusState121, EraseConfigInfo:=0,
25   OperationMode:=1, SubmoduleType:=16#0021, SubmoduleSize:=16#0001, SubmoduleNumber:=6, SerialPortNumber:=1, StartAddress:=1000,
26  xDone=>Done6, xBusy=>Busy6, xError=>Error6, wErrorID=>ErrorID6);
27
28 Set_Comm_ConfigItem7(Execute:=Done6, Node_ID:=Nodeid1, Slot_Addr:=1, RunModule:=0, LBusState:=LBusState121, EraseConfigInfo:=0,
29   OperationMode:=1, SubmoduleType:=16#0022, SubmoduleSize:=16#0001, SubmoduleNumber:=7, SerialPortNumber:=1, StartAddress:=1000,
30  xDone=>Done7, xBusy=>Busy7, xError=>Error7, wErrorID=>ErrorID7);
31
32
33 Set_Comm_ConfigItem8(Execute:=Done7, Node_ID:=Nodeid1, Slot_Addr:=2, RunModule:=0, LBusState:=LBusState121, EraseConfigInfo:=1,
34   OperationMode:=1, SubmoduleType:=16#0023, SubmoduleSize:=16#0001, SubmoduleNumber:=1, SerialPortNumber:=0, StartAddress:=0,
35  xDone=>Done8, xBusy=>Busy8, xError=>Error8, wErrorID=>ErrorID8);
36
37 Set_Comm_ConfigItem9(Execute:=Done8, Node_ID:=Nodeid1, Slot_Addr:=2, RunModule:=0, LBusState:=LBusState121, EraseConfigInfo:=0,
38   OperationMode:=0, SubmoduleType:=16#0001, SubmoduleSize:=16#0010, SubmoduleNumber:=2, SerialPortNumber:=1,
39   SlaveID:=1, StartAddress:=0, DataLength:=128, NumberOfRetransmissions:=1, ConfigurationItemCycleTime:=1000,
40  xDone=>Done9, xBusy=>Busy9, xError=>Error9, wErrorID=>ErrorID9);
41
42 Set_Comm_ConfigItem10(Execute:=Done9, Node_ID:=Nodeid1, Slot_Addr:=2, RunModule:=0, LBusState:=LBusState121, EraseConfigInfo:=0,
43   OperationMode:=0, SubmoduleType:=16#0002, SubmoduleSize:=16#0001, SubmoduleNumber:=3, SerialPortNumber:=1,
44   SlaveID:=1, StartAddress:=0, DataLength:=8, NumberOfRetransmissions:=1, ConfigurationItemCycleTime:=1000,
45  xDone=>Done10, xBusy=>Busy10, xError=>Error10, wErrorID=>ErrorID10);
46
47 Set_Comm_ConfigItem11(Execute:=Done10, Node_ID:=Nodeid1, Slot_Addr:=2, RunModule:=0, LBusState:=LBusState121, EraseConfigInfo:=0,
48   OperationMode:=0, SubmoduleType:=16#0003, SubmoduleSize:=16#0010, SubmoduleNumber:=4, SerialPortNumber:=1,
49   SlaveID:=1, StartAddress:=0, DataLength:=16, NumberOfRetransmissions:=1, ConfigurationItemCycleTime:=1000,
50  xDone=>Done11, xBusy=>Busy11, xError=>Error11, wErrorID=>ErrorID11);
51
52 Set_Comm_ConfigItem12(Execute:=Done11, Node_ID:=Nodeid1, Slot_Addr:=2, RunModule:=0, LBusState:=LBusState121, EraseConfigInfo:=0,
53   OperationMode:=0, SubmoduleType:=16#0004, SubmoduleSize:=16#0005, SubmoduleNumber:=5, SerialPortNumber:=1,
54   SlaveID:=1, StartAddress:=0, DataLength:=5, NumberOfRetransmissions:=1, ConfigurationItemCycleTime:=1000,
55  xDone=>Done12, xBusy=>Busy12, xError=>Error12, wErrorID=>ErrorID12);
56
57 Set_Comm_ConfigItem13(Execute:=Done12, Node_ID:=Nodeid1, Slot_Addr:=2, RunModule:=0, LBusState:=LBusState121, EraseConfigInfo:=0,
58   OperationMode:=0, SubmoduleType:=16#000F, SubmoduleSize:=16#0001, SubmoduleNumber:=6, SerialPortNumber:=1,
59   SlaveID:=1, StartAddress:=1000, DataLength:=8, NumberOfRetransmissions:=1, ConfigurationItemCycleTime:=1000,
60  xDone=>Done13, xBusy=>Busy13, xError=>Error13, wErrorID=>ErrorID13);
61
62 Set_Comm_ConfigItem14(Execute:=Done13, Node_ID:=Nodeid1, Slot_Addr:=2, RunModule:=1, LBusState:=LBusState121, EraseConfigInfo:=0,
63   OperationMode:=0, SubmoduleType:=16#0010, SubmoduleSize:=16#0002, SubmoduleNumber:=7, SerialPortNumber:=1,
64   SlaveID:=1, StartAddress:=1000, DataLength:=2, NumberOfRetransmissions:=1, ConfigurationItemCycleTime:=1000,
65  xDone=>Done14, xBusy=>Busy14, xError=>Error14, wErrorID=>ErrorID14);
66

```

Note

- As shown in the example: When multiple function blocks are called, they must be used sequentially and connected end to end. They cannot be used in parallel or triggered simultaneously.
- When the module operates as a slave, if multiple submodules of the same type are added and the starting addresses of the submodules are identical, read and write operations from the master will only take effect on the first submodule that meets the conditions.

b. Load the program into the task, as shown in the figure below.

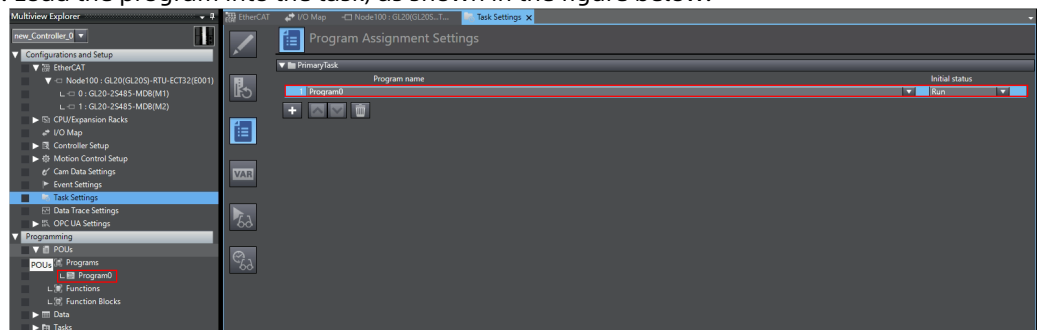

c. After the PLC is online, transfer the program to the PLC (download the program to the PLC), as shown in the figure below.

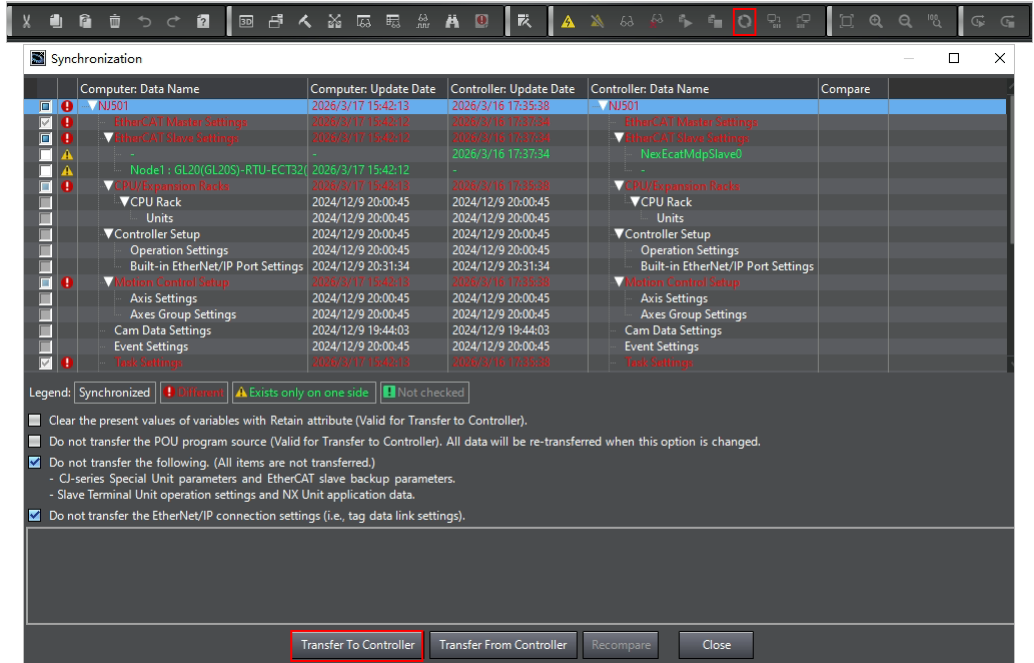

d. In the pop-up dialog box, click "Yes," as shown in the figure below.

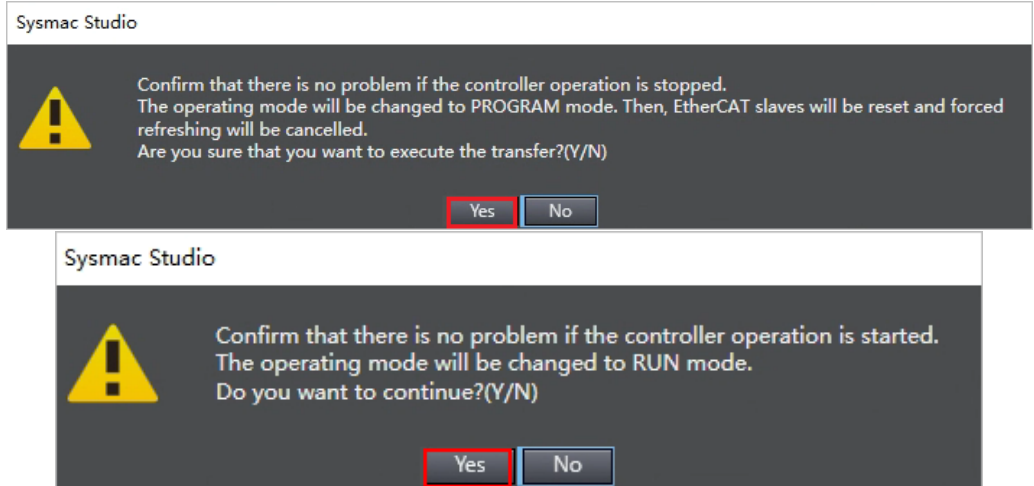

e. After program synchronization is completed, click "Close," as shown in the figure below.

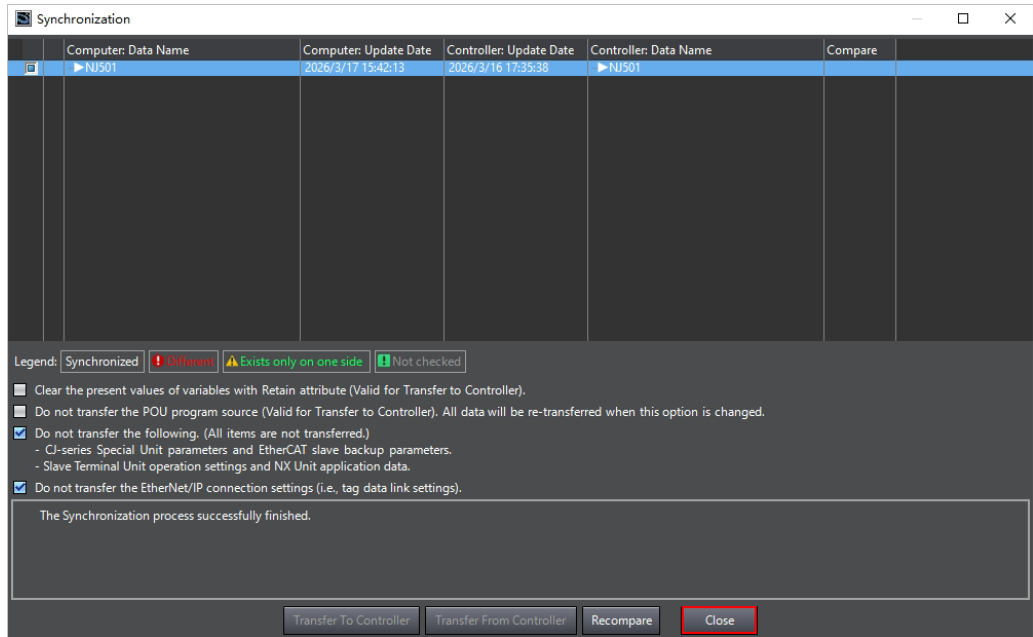

f. The program is running normally, as shown in the figure below.

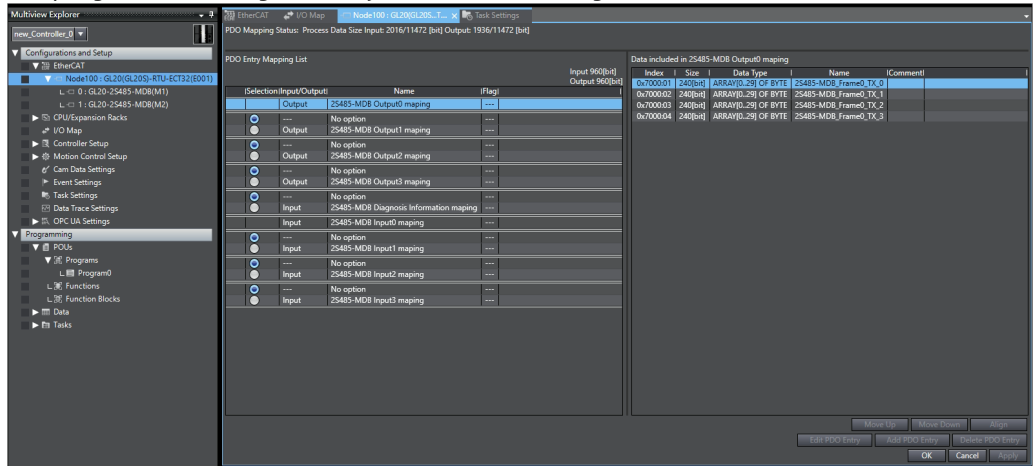

Note

All function block "xDone" are "TRUE", and "wErrorID" is zero. The PR light of the module changes from flashing to steady ON, indicating that the configuration data has been successfully sent, and the module is running normally.

g. Change the process data size.

The process data objects (PDO) are mapped in 4 sets of 120 bytes for user selection. Due to limitations in the EtherCAT PDO transmission mechanism, only 480 bytes are currently allocated for data transmission and reception by communication modules. The maximum PDO byte count per module corresponding to the number of modules is shown in the following table.

Number of modules	Maximum PDO byte count per module
1	480 bytes
2	240 bytes

Number of modules	Maximum PDO byte count per module
3	120 bytes
4	120 bytes

1). The default input and output process data are each 120 bytes, as shown in the figure below.

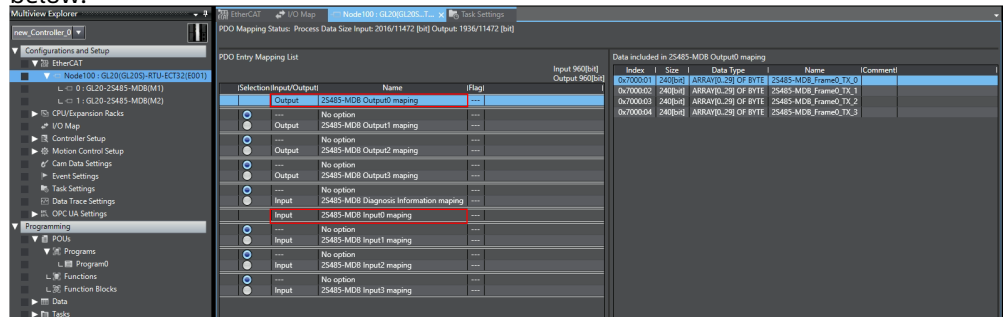

2). To increase output process data: If the output process data exceeds 120 bytes, select "25485-MDB Output1 mapping" to add the 120-byte output process data. The total output process data becomes 240 bytes, as shown in the figure below.

3). To increase input process data: If the input process data exceeds 120 bytes, select "25485-MDB Input1 mapping" to add the 120-byte input process data. The total output process data becomes 240 bytes, as shown in the figure below.

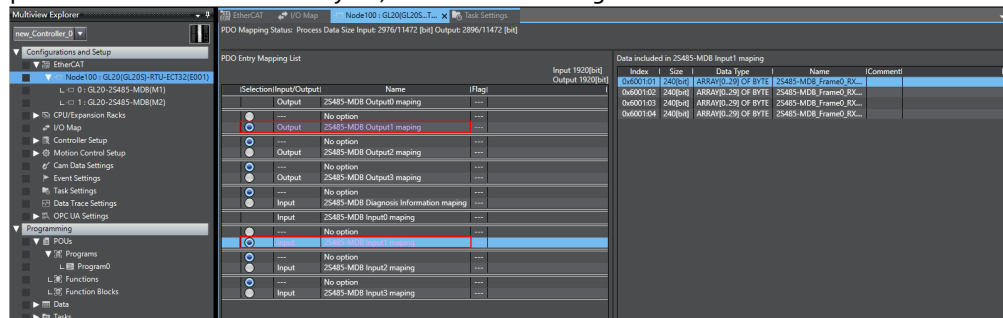

4). Click "Online", and then click "Yes" in the pop-up dialog box, as shown in the figure below.

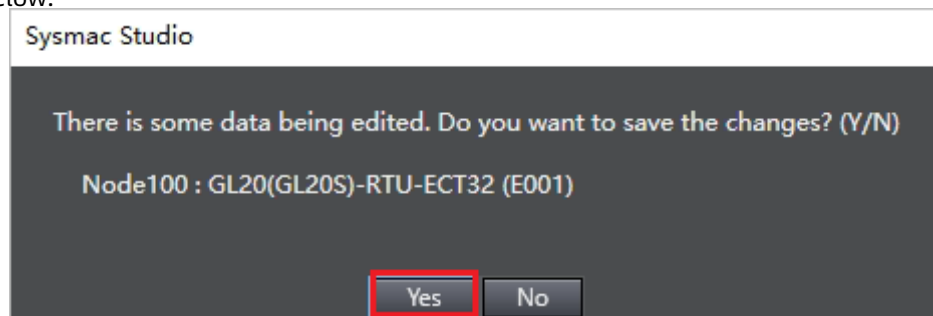

5). Click "Synchronize", and then click "Send to Controller" to complete the process data size change.

6). Select "Configuration and Setup > I/O Mapping," and map the associated variables, as shown in the figure below.

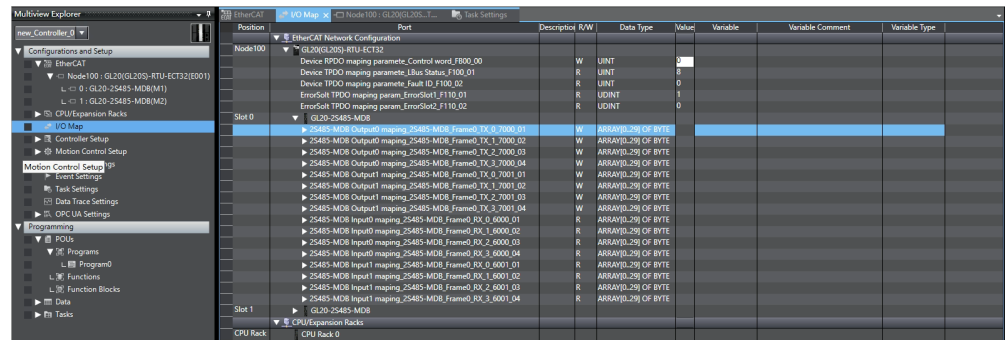

- Configure free protocol commands for Omron PLCs.
 - a. Take serial port 0 as an example, and set the free protocol communication mode to request-response mode. First, call the "F: Control Status Module" control and status submodule. Then, select the appropriate input/output data submodule according to the input/output data size (In this example, both input and output data submodule have a data size of 4 words, that is, 8 bytes), as shown in the figure below.

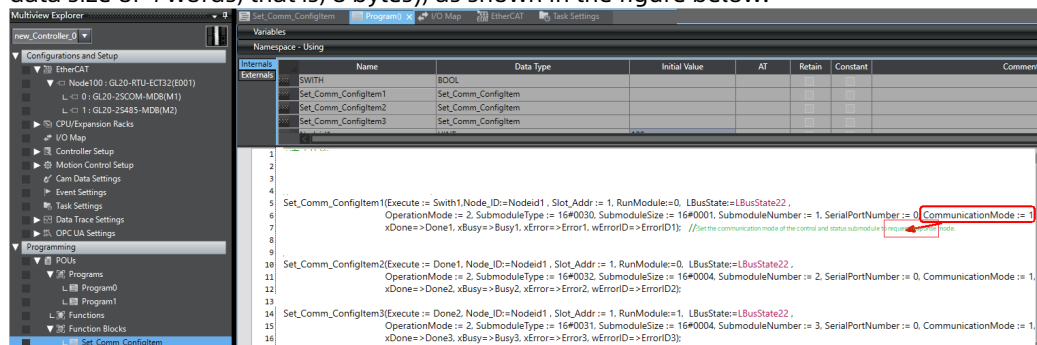

The description of each byte in the "F: Control Status Module" control and status submodule (4-byte status control output) is shown in the following table.

Byte	Bit	Description	Note
Byte 1	bit0	Trigger control word	Control word
	bit1	Completion reset	
	bit2	Parity error reset	
	bit3	Timeout error reset	
	bit4	Error counter reset	
	bit5	Receive counter reset	
	bit6	Received data reset	
Byte 2	Unsigned8	Reserve	Valid data length: compatible with GL20-RTU-ECT32 (476Byte) /GL20-RTU-PN (474Byte). Defaults to maximum value if this limit is exceeded.
Byte 3	Unsigned8	Transmit frame byte length (high byte)	
Byte 4	Unsigned8	Transmit frame byte length (low byte)	

- b. The control output mapping for the "F:Control Status Module" control and status submodule is shown in the following figure (with the trigger control word enabled and the transmit frame byte length set to 8 bytes). Map the data to be output as shown in the following figure.

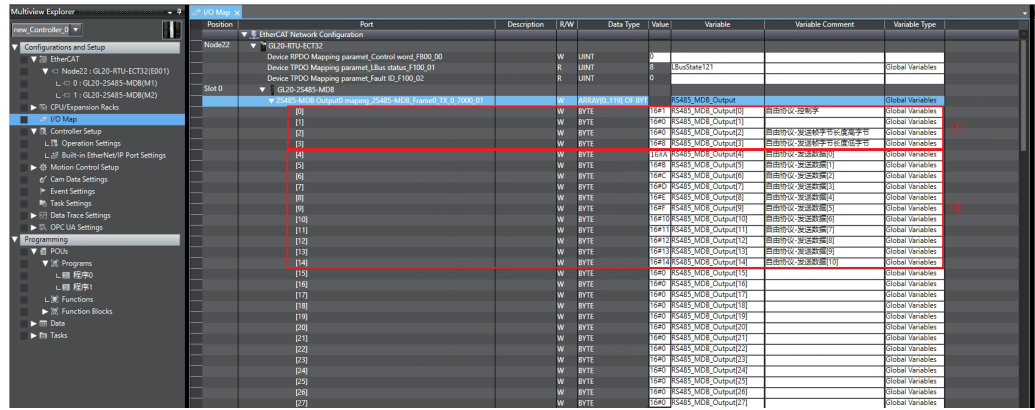

No.	Description
①	"F:Control Status Module" control and status submodule (4-byte status control output)
②	Output data mapping

c. When the 2S485-MDB module detects a rising edge of the trigger control word, it transmits the 8-byte data from the output data area via the serial port, and manually simulates a 10-byte response data as an acknowledgment.

The description of each byte in the "F:Control Status Module" control and status submodule (8-byte status feedback input) is shown in the following table.

Byte	Bit	Description	Note
Byte 1	bit0	Busy status	Serial port status
	bit1	Communication completion flag	
	bit2	Parity error	
	bit3	Timeout error	
	bit4 to bit7	Reserve	
Byte 1	Unsigned8	Reserve	-
Byte 3	Unsigned8	Receive error frame count (high byte)	-
Byte 4	Unsigned8	Receive error frame count (low byte)	-
Byte 5	Unsigned8	Total received data frame count (high byte)	-
Byte 6	Unsigned8	Total received data frame count (low byte)	-
Byte 7	Unsigned8	Current receive frame byte length (high byte)	-
Byte 8	Unsigned8	Current receive frame byte length (low byte)	-

d. In the figure above, the first byte is 2, indicating communication completion. The receive error frame count is 0. The total received data frame count is 1, and the current receive frame byte length is 10 bytes. Since the input data submodule is set to 8 bytes, only the 8-byte response data are displayed, as shown in the figure below.

Position	Part	Description	R/W	Data Type	Value	Variable	Variable Comment	Variable Type
93	GL20-RTU-ECT12	Device TPDO Mapping param: Control word_F100_00	R	UINT	0			
94	GL20-RTU-ECT12	Device TPDO Mapping param: LBus status_F100_01	R	UINT	0	lbusData121		Global Variables
95	GL20-RTU-ECT12	Device TPDO Mapping param: Fault ID_F100_02	R	UINT	0			
96	GL20-2S485-MDB	2S485-MDB Output0 mapping_2S485-MDB_Frame_TX_0_7000_01	W	ARRAY[0..119] OF BYTE		2S485_MDB_Output		Global Variables
97	GL20-2S485-MDB	2S485-MDB Output1 mapping_2S485-MDB_Frame_TX_1_7001_01	W	ARRAY[0..119] OF BYTE		2S485_MDB_Input		Global Variables
98	GL20-2S485-MDB	2S485-MDB Input0 mapping_2S485-MDB_Frame_RX_0_7000_01	R	BYTE	1642	2S485_MDB_Input0	自由接收-状态反馈	Global Variables
99	GL20-2S485-MDB	2S485-MDB Input1 mapping_2S485-MDB_Frame_RX_1_7001_01	R	BYTE	1643	2S485_MDB_Input1	自由接收-接收数据帧计数 帧字节	Global Variables
100	GL20-2S485-MDB	2S485-MDB Input2 mapping_2S485-MDB_Frame_RX_2_7002_01	R	BYTE	1644	2S485_MDB_Input2	自由接收-接收数据帧计数 帧字节	Global Variables
101	GL20-2S485-MDB	2S485-MDB Input3 mapping_2S485-MDB_Frame_RX_3_7003_01	R	BYTE	1645	2S485_MDB_Input3	自由接收-接收数据帧计数 帧字节	Global Variables
102	GL20-2S485-MDB	2S485-MDB Input4 mapping_2S485-MDB_Frame_RX_4_7004_01	R	BYTE	1646	2S485_MDB_Input4	自由接收-接收数据帧计数 帧字节	Global Variables
103	GL20-2S485-MDB	2S485-MDB Input5 mapping_2S485-MDB_Frame_RX_5_7005_01	R	BYTE	1647	2S485_MDB_Input5	自由接收-接收数据帧计数 帧字节	Global Variables
104	GL20-2S485-MDB	2S485-MDB Input6 mapping_2S485-MDB_Frame_RX_6_7006_01	R	BYTE	1648	2S485_MDB_Input6	自由接收-接收数据帧计数 帧字节	Global Variables
105	GL20-2S485-MDB	2S485-MDB Input7 mapping_2S485-MDB_Frame_RX_7_7007_01	R	BYTE	1649	2S485_MDB_Input7	自由接收-接收数据帧计数 帧字节	Global Variables
106	GL20-2S485-MDB	2S485-MDB Input8 mapping_2S485-MDB_Frame_RX_8_7008_01	R	BYTE	1650	2S485_MDB_Input8	自由接收-接收数据帧计数 帧字节	Global Variables
107	GL20-2S485-MDB	2S485-MDB Input9 mapping_2S485-MDB_Frame_RX_9_7009_01	R	BYTE	1651	2S485_MDB_Input9	自由接收-接收数据帧计数 帧字节	Global Variables
108	GL20-2S485-MDB	2S485-MDB Input10 mapping_2S485-MDB_Frame_RX_10_7010_01	R	BYTE	1652	2S485_MDB_Input10	自由接收-接收数据帧计数 帧字节	Global Variables
109	GL20-2S485-MDB	2S485-MDB Input11 mapping_2S485-MDB_Frame_RX_11_7011_01	R	BYTE	1653	2S485_MDB_Input11	自由接收-接收数据帧计数 帧字节	Global Variables
110	GL20-2S485-MDB	2S485-MDB Input12 mapping_2S485-MDB_Frame_RX_12_7012_01	R	BYTE	1654	2S485_MDB_Input12	自由接收-接收数据帧计数 帧字节	Global Variables
111	GL20-2S485-MDB	2S485-MDB Input13 mapping_2S485-MDB_Frame_RX_13_7013_01	R	BYTE	1655	2S485_MDB_Input13	自由接收-接收数据帧计数 帧字节	Global Variables
112	GL20-2S485-MDB	2S485-MDB Input14 mapping_2S485-MDB_Frame_RX_14_7014_01	R	BYTE	1656	2S485_MDB_Input14	自由接收-接收数据帧计数 帧字节	Global Variables
113	GL20-2S485-MDB	2S485-MDB Input15 mapping_2S485-MDB_Frame_RX_15_7015_01	R	BYTE	1657	2S485_MDB_Input15	自由接收-接收数据帧计数 帧字节	Global Variables
114	GL20-2S485-MDB	2S485-MDB Input16 mapping_2S485-MDB_Frame_RX_16_7016_01	R	BYTE	1658	2S485_MDB_Input16	自由接收-接收数据帧计数 帧字节	Global Variables
115	GL20-2S485-MDB	2S485-MDB Input17 mapping_2S485-MDB_Frame_RX_17_7017_01	R	BYTE	1659	2S485_MDB_Input17	自由接收-接收数据帧计数 帧字节	Global Variables
116	GL20-2S485-MDB	2S485-MDB Input18 mapping_2S485-MDB_Frame_RX_18_7018_01	R	BYTE	1660	2S485_MDB_Input18	自由接收-接收数据帧计数 帧字节	Global Variables
117	GL20-2S485-MDB	2S485-MDB Input19 mapping_2S485-MDB_Frame_RX_19_7019_01	R	BYTE	1661	2S485_MDB_Input19	自由接收-接收数据帧计数 帧字节	Global Variables
118	GL20-2S485-MDB	2S485-MDB Input20 mapping_2S485-MDB_Frame_RX_20_7020_01	R	BYTE	1662	2S485_MDB_Input20	自由接收-接收数据帧计数 帧字节	Global Variables
119	GL20-2S485-MDB	2S485-MDB Input21 mapping_2S485-MDB_Frame_RX_21_7021_01	R	BYTE	1663	2S485_MDB_Input21	自由接收-接收数据帧计数 帧字节	Global Variables
120	GL20-2S485-MDB	2S485-MDB Input22 mapping_2S485-MDB_Frame_RX_22_7022_01	R	BYTE	1664	2S485_MDB_Input22	自由接收-接收数据帧计数 帧字节	Global Variables
121	GL20-2S485-MDB	2S485-MDB Input23 mapping_2S485-MDB_Frame_RX_23_7023_01	R	BYTE	1665	2S485_MDB_Input23	自由接收-接收数据帧计数 帧字节	Global Variables
122	GL20-2S485-MDB	2S485-MDB Input24 mapping_2S485-MDB_Frame_RX_24_7024_01	R	BYTE	1666	2S485_MDB_Input24	自由接收-接收数据帧计数 帧字节	Global Variables
123	GL20-2S485-MDB	2S485-MDB Input25 mapping_2S485-MDB_Frame_RX_25_7025_01	R	BYTE	1667	2S485_MDB_Input25	自由接收-接收数据帧计数 帧字节	Global Variables

No.	Description
①	8-Byte status feedback input from control and status submodule
②	Received data mapped to input data mapping area

The status feedback of the "F:Control Status Module" control and status submodule under different scenarios is described as follows.

- Request-response mode: On the rising edge of the trigger control word, the triggered serial port sends data once. The serial port transmits data according to the configured transmit frame byte length. During transmission, the busy status bit is set to 1. The timing diagram is shown below.

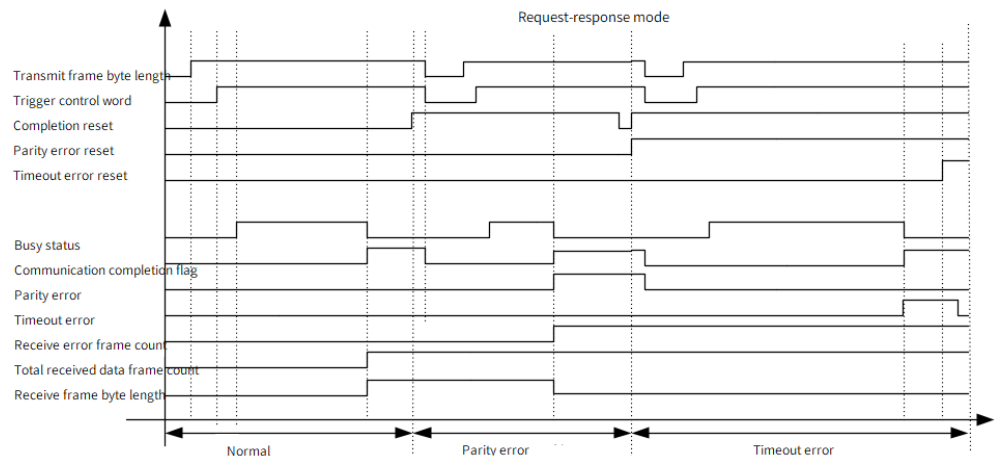

- ◇ Normal mode: If a response is received via the serial port within the timeout period, the busy status bit is cleared, the communication completion flag is set to 1, the total received data frame count is incremented by 1, and the current receive frame byte length is set to the actual received length.
- ◇ Parity error: If a response is received via the serial port within the timeout period but a parity error occurs, the busy status bit is cleared, the communication completion flag is set to 1, the parity error flag is set to 1, the receive error frame count is incremented by 1, and the current receive frame byte length is set to 0.
- ◇ Timeout error: If a response is received via the serial port within the timeout period, the busy status bit is cleared, the communication completion flag is set to 1, the timeout error is set to 1, the receive error frame count is incremented by 1, and the current receive frame byte length is set to 0.

- The timing diagram for the receive-only mode is shown below.

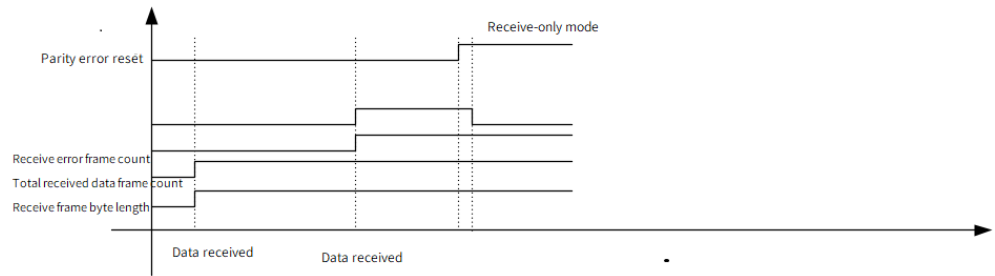

- ◊ When the module receives data, the total received frame count is incremented by 1, and the current receive frame byte length is set to the actual received length.
- ◊ When the module receives data but a parity error occurs, the parity error is set to 1, the receive error frame count is incremented by 1, the total received data frame count is incremented by 1, and the current receive frame byte length is set to the actual received length.

- The timing diagram for the transmit-only mode is shown below. On the rising edge of the trigger control word, the triggered serial port sends data once. The serial port transmits data according to the configured transmit frame byte length. During transmission, the busy status bit is set to 1.

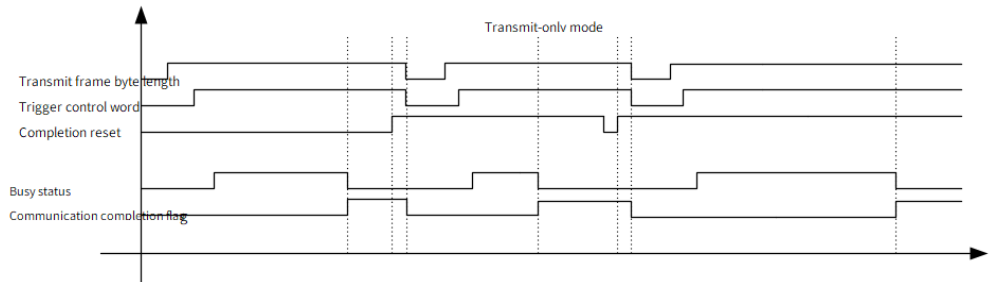

After the data transmission, the busy status bit is cleared, and the communication completion flag is set to 1.

- When the serial port status is cleared:
 - ◊ On the rising edge of the completion reset, the communication completion flag is cleared.
 - ◊ On the rising edge of the parity error reset, the parity error is cleared.
 - ◊ On the rising edge of the timeout error reset, the timeout error is cleared.
 - ◊ On the rising edge of the error counter reset, the receive error frame count is cleared.
 - ◊ On the rising edge of the receive counter reset, the total received data frame count is cleared.
 - ◊ On the rising edge of the received data reset, the current receive frame byte length is cleared.

4. Set condition trigger (rising edge trigger, level trigger).

- a. Configure serial port 0/1, set it as condition trigger, as shown in the table below.

Index	Subindex	Parameter	Subparameter	Description	Bit	Data type	Configuration value range	Sub parameter default value	Parameter default value
0x8000	6	COM0 (M/S): Master Control And Slave ID	M: Read Timeout Action	Action upon read timeout	bit0	UINT	• 0: Retain the last input value • 1: Clear	0	0x0110
			M: Output Mode	Data output mode	bit1		Not available yet. Default: Polling mode	0	
			M: Module Control	Module control enable	bit2		• 0: Disable • 1: Enable	0	
		COM0 (M/S): Master Control And Slave ID	M: Module Control Mode	Module control method	bit3		• 0: Level triggered (active continuously) • 1: Rising edge triggered (single shot)	0	
			M: Power On Event Output	Power-on time output	bit4		Default 1: enabled. Cannot be changed to 0	1	
			S: Slave ID	Slave ID	bit8 to bit15		1 to 247	1	

When M: ModuleControl is enabled, serial port 0/1 is set to condition trigger mode. When M: ModuleControl is disabled, serial port 0/1 is set to polling mode. The module control mode takes effect only when M: ModuleControl is enabled. Level trigger sends continuously when the condition is met; rising edge trigger sends only once when the condition is met.

b. Add the "Control Output" submodule as shown in the figure below.

```

MAIN* x Library Manager B
19
20 sNetId : T_AmsNetId := '5.107.105.196.4.1' ;
21 nSlaveAddr : UINT := 1001;
22
84
85
86
87 Set_Comm_ConfigItem1(Execute:=Swit1, sNetId := sNetId, nEtherCATSlaveAddr := nSlaveAddr, Slot_Addr:=1, RunModule:=0, LBusState:=LBusState1001, EraseConfigInfo:=1,
88 OperationMode:=0, SubmoduleType:=16#0014, SubmoduleSize:=16#0002, SubmoduleNumber:=1, SerialPortNumber:=0, SlaveID:=1,
89 xDone=>Done1, xBusy=>Busy1, xError=>Error1, wErrorID=>ErrorID1); //
90 Control output of 2 bytes
91 Set_Comm_ConfigItem2(Execute:=Done1, sNetId := sNetId, nEtherCATSlaveAddr := nSlaveAddr, Slot_Addr:=1, RunModule:=0, LBusState:=LBusState1001, EraseConfigInfo:=0,
92 OperationMode:=0, SubmoduleType:=16#0001, SubmoduleSize:=16#0001, SubmoduleNumber:=2, SerialPortNumber:=0,
93 SlaveID:=10, StartAddress:=0, DataLength:=1, NumberOfRetransmissions:=0, ConfigurationItemCycleTime:=1000,
94 xDone=>Done2, xBusy=>Busy2, xError=>Error2, wErrorID=>ErrorID2); Configuration item 1
95
96 Set_Comm_ConfigItem3(Execute:=Done2, sNetId := sNetId, nEtherCATSlaveAddr := nSlaveAddr, Slot_Addr:=1, RunModule:=0, LBusState:=LBusState1001, EraseConfigInfo:=0,
97 OperationMode:=0, SubmoduleType:=16#0003, SubmoduleSize:=16#0001, SubmoduleNumber:=3, SerialPortNumber:=0,
98 SlaveID:=10, StartAddress:=12, DataLength:=1, NumberOfRetransmissions:=0, ConfigurationItemCycleTime:=1000,
99 xDone=>Done3, xBusy=>Busy3, xError=>Error3, wErrorID=>ErrorID3); Configuration item 2
100
101 Set_Comm_ConfigItem4(Execute:=Done3, sNetId := sNetId, nEtherCATSlaveAddr := nSlaveAddr, Slot_Addr:=1, RunModule:=0, LBusState:=LBusState1001, EraseConfigInfo:=0,
102 OperationMode:=0, SubmoduleType:=16#0003, SubmoduleSize:=16#0001, SubmoduleNumber:=4, SerialPortNumber:=0,
103 SlaveID:=10, StartAddress:=13, DataLength:=1, NumberOfRetransmissions:=0, ConfigurationItemCycleTime:=1000,
104 xDone=>Done4, xBusy=>Busy4, xError=>Error4, wErrorID=>ErrorID4); Configuration item 3
105
106 Set_Comm_ConfigItem5(Execute:=Done4, sNetId := sNetId, nEtherCATSlaveAddr := nSlaveAddr, Slot_Addr:=1, RunModule:=1, LBusState:=LBusState1001, EraseConfigInfo:=0,
107 OperationMode:=0, SubmoduleType:=16#0003, SubmoduleSize:=16#0001, SubmoduleNumber:=5, SerialPortNumber:=0,
108 SlaveID:=10, StartAddress:=15, DataLength:=1, NumberOfRetransmissions:=0, ConfigurationItemCycleTime:=1000,
109 xDone=>Done5, xBusy=>Busy5, xError=>Error5, wErrorID=>ErrorID5); Configuration item 4
110

```

For condition trigger, it is recommended to add the "Control Output" submodule during the first call of the function block.

- c. After the "Control Output" submodule is added, the first two bytes of the process output data will be used to control the trigger of configuration items 1, 2, 3, 4, and so on.
- d. For the program in step b, the second bit of the first byte for the "Control Output" submodule process output data controls configuration item 1. When this second bit is true, it triggers configuration item 1 to send a query message. The third bit of the first byte in the process output data controls configuration item 2. When this third bit is true, it triggers configuration item 2 to send a message, as shown in the figure below.

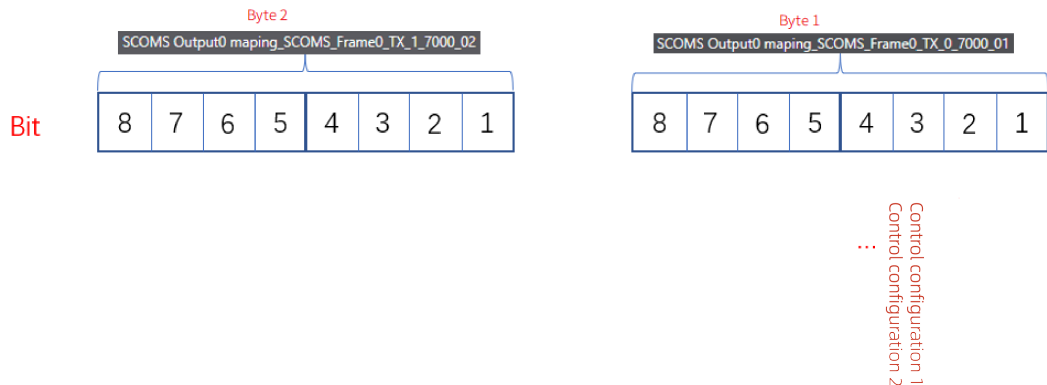

- e. In the project, the first two bytes of the "M:Control Output submodule" process data are associated via variables. The values of these variables determine the condition triggering of the configuration items.

6.3 Submodule ID Description

- The submodule descriptions for Modbus master mode are shown in the table below.

Type	SubmoduleName	SubmoduleNumber		Unit
		SubmoduleType	SubmoduleSize	
Read coils (0xxxx)	Read 008 Bits 0xxxx	0x0001	0x0001	Byte
	Read 016 Bits 0xxxx		0x0002	
	Read 024 Bits 0xxxx		0x0003	
	Read 032 Bits 0xxxx		0x0004	
	Read 040 Bits 0xxxx		0x0005	
	Read 048 Bits 0xxxx		0x0006	
	Read 056 Bits 0xxxx		0x0007	
	Read 064 Bits 0xxxx		0x0008	
	Read 072 Bits 0xxxx		0x0009	
	Read 080 Bits 0xxxx		0x000A	
	Read 088 Bits 0xxxx		0x000B	
	Read 096 Bits 0xxxx		0x000C	
	Read 104 Bits 0xxxx		0x000D	
	Read 112 Bits 0xxxx		0x000E	
	Read 120 Bits 0xxxx		0x000F	
Read 128 Bits 0xxxx	0x0010			

Type	SubmoduleName	SubmoduleNumber		Unit
		SubmoduleType	SubmoduleSize	
Read discrete inputs (1xxxx)	Read 008 Bits 1xxxx	0x0002	0x0001	Byte
	Read 016 Bits 1xxxx		0x0002	
	Read 024 Bits 1xxxx		0x0003	
	Read 032 Bits 1xxxx		0x0004	
	Read 040 Bits 1xxxx		0x0005	
	Read 048 Bits 1xxxx		0x0006	
	Read 056 Bits 1xxxx		0x0007	
	Read 064 Bits 1xxxx		0x0008	
	Read 072 Bits 1xxxx		0x0009	
	Read 080 Bits 1xxxx		0x000A	
	Read 088 Bits 1xxxx		0x000B	
	Read 096 Bits 1xxxx		0x000C	
	Read 104 Bits 1xxxx		0x000D	
	Read 112 Bits 1xxxx		0x000E	
	Read 120 Bits 1xxxx		0x000F	
Read 128 Bits 1xxxx	0x0010			
Read input registers (3xxxx)	Read 01 Words 3xxxx	0x0004	0x0001	Dic- tion
	Read 02 Words 3xxxx		0x0002	
	Read 03 Words 3xxxx		0x0003	
	Read 04 Words 3xxxx		0x0004	
	Read 05 Words 3xxxx		0x0005	
	Read 06 Words 3xxxx		0x0006	
	Read 07 Words 3xxxx		0x0007	
	Read 08 Words 3xxxx		0x0008	
	Read 09 Words 3xxxx		0x0009	
	Read 10 Words 3xxxx		0x000A	
	Read 11 Words 3xxxx		0x000B	
	Read 12 Words 3xxxx		0x000C	
	Read 13 Words 3xxxx		0x000D	
	Read 14 Words 3xxxx		0x000E	
	Read 15 Words 3xxxx		0x000F	
	Read 16 Words 3xxxx		0x0010	

Type	SubmoduleName	SubmoduleNumber		Unit
		SubmoduleType	SubmoduleSize	
Read holding registers (4xxxx)	Read 01 Words 4xxxx	0x0003	0x0001	Word
	Read 02 Words 4xxxx		0x0002	
	Read 03 Words 4xxxx		0x0003	
	Read 04 Words 4xxxx		0x0004	
	Read 05 Words 4xxxx		0x0005	
	Read 06 Words 4xxxx		0x0006	
	Read 07 Words 4xxxx		0x0007	
	Read 08 Words 4xxxx		0x0008	
	Read 09 Words 4xxxx		0x0009	
	Read 10 Words 4xxxx		0x000A	
	Read 11 Words 4xxxx		0x000B	
	Read 12 Words 4xxxx		0x000C	
	Read 13 Words 4xxxx		0x000D	
	Read 14 Words 4xxxx		0x000E	
	Read 15 Words 4xxxx		0x000F	
	Read 16 Words 4xxxx		0x0010	
Write single coil (0xxxx)	Write Single Coll (0xxxx)	0x0005	0x0001	Byte
Write single register (4xxxx)	Write Single Register (4xxxx)	0x0006	0x0001	Word
Write coils (0xxxx)	Write 008 Bits 0xxxx	0x000F	0x0001	Byte
	Write 016 Bits 0xxxx		0x0002	
	Write 024 Bits 0xxxx		0x0003	
	Write 032 Bits 0xxxx		0x0004	
	Write 040 Bits 0xxxx		0x0005	
	Write 048 Bits 0xxxx		0x0006	
	Write 056 Bits 0xxxx		0x0007	
	Write 064 Bits 0xxxx		0x0008	
	Write 072 Bits 0xxxx		0x0009	
	Write 080 Bits 0xxxx		0x000A	
	Write 088 Bits 0xxxx		0x000B	
	Write 096 Bits 0xxxx		0x000C	
	Write 104 Bits 0xxxx		0x000D	
	Write 112 Bits 0xxxx		0x000E	
	Write 120 Bits 0xxxx		0x000F	
	Write 128 Bits 0xxxx		0x0010	

Type	SubmoduleName	SubmoduleNumber		Unit
		SubmoduleType	SubmoduleSize	
Write holding registers (4xxxx)	Write 01 Words 3xxxx	0x0010	0x0001	Word
	Write 02 Words 3xxxx		0x0002	
	Write 03 Words 3xxxx		0x0003	
	Write 04 Words 3xxxx		0x0004	
	Write 05 Words 3xxxx		0x0005	
	Write 06 Words 3xxxx		0x0006	
	Write 07 Words 3xxxx		0x0007	
	Write 08 Words 3xxxx		0x0008	
	Write 09 Words 3xxxx		0x0009	
	Write 10 Words 3xxxx		0x000A	
	Write 11 Words 3xxxx		0x000B	
	Write 12 Words 3xxxx		0x000C	
	Write 13 Words 3xxxx		0x000D	
	Write 14 Words 3xxxx		0x000E	
	Write 15 Words 3xxxx		0x000F	
	Write 16 Words 3xxxx		0x0010	
Diagnostic module	Polling Time Input (ms)	0x0013	0x0001	Word
	Control Output (08CH)	0x0014	0x0001	Byte
	Control Output (16CH)		0x0002	
	Control Output (24CH)		0x0003	
	Control Output (32CH)		0x0004	

- The submodule descriptions for Modbus slave mode are shown in the table below.

Type	SubmoduleName	SubmoduleNumber		Unit
		SubmoduleType	SubmoduleSize	
Read coils (0xxxx)	Read 0001 Bytes 0xxxx	0x0021	0x0001	Byte
	Read 0002 Bytes 0xxxx		0x0002	
	Read 0004 Bytes 0xxxx		0x0004	
	Read 0008 Bytes 0xxxx		0x0008	
	Read 0016 Bytes 0xxxx		0x0010	
	Read 0032 Bytes 0xxxx		0x0020	
	Read 0064 Bytes 0xxxx		0x0040	
	Read 0128 Bytes 0xxxx		0x0080	
	Read 0256 Bytes 0xxxx		0x0100	
Read holding registers (4xxxx)	Read 0001 Words 4xxxx	0x0022	0x0001	Word
	Read 0002 Words 4xxxx		0x0002	
	Read 0004 Words 4xxxx		0x0004	
	Read 0008 Words 4xxxx		0x0008	
	Read 0016 Words 4xxxx		0x0010	
	Read 0032 Words 4xxxx		0x0020	
	Read 0064 Words 4xxxx		0x0040	
	Read 0128 Words 4xxxx		0x0080	

Type	SubmoduleName	SubmoduleNumber		Unit
		SubmoduleType	SubmoduleSize	
Write coils (0xxxx)	Write 0001 Bytes 0xxxx	0x0023	0x0001	Byte
	Write 0002 Bytes 0xxxx		0x0002	
	Write 0004 Bytes 0xxxx		0x0004	
	Write 0008 Bytes 0xxxx		0x0008	
	Write 0016 Bytes 0xxxx		0x0010	
	Write 0032 Bytes 0xxxx		0x0020	
	Write 0064 Bytes 0xxxx		0x0040	
	Write 0128 Bytes 0xxxx		0x0080	
	Write 0256 Bytes 0xxxx		0x0100	
Write discrete inputs (1xxxx)	Write 0001 Bytes 1xxxx	0x0024	0x0001	Byte
	Write 0002 Bytes 1xxxx		0x0002	
	Write 0004 Bytes 1xxxx		0x0004	
	Write 0008 Bytes 1xxxx		0x0008	
	Write 0016 Bytes 1xxxx		0x0010	
	Write 0032 Bytes 1xxxx		0x0020	
	Write 0064 Bytes 1xxxx		0x0040	
	Write 0128 Bytes 1xxxx		0x0080	
	Write 0256 Bytes 1xxxx		0x0100	
Write input registers (3xxxx)	Write 0001 Words 3xxxx	0x0025	0x0001	Word
	Write 0002 Words 3xxxx		0x0002	
	Write 0004 Words 3xxxx		0x0004	
	Write 0008 Words 3xxxx		0x0008	
	Write 0016 Words 3xxxx		0x0010	
	Write 0032 Words 3xxxx		0x0020	
	Write 0064 Words 3xxxx		0x0040	
	Write 0128 Words 3xxxx		0x0080	
Write holding registers (4xxxx)	Write 0001 Words 4xxxx	0x0026	0x0001	Word
	Write 0002 Words 4xxxx		0x0002	
	Write 0004 Words 4xxxx		0x0004	
	Write 0008 Words 4xxxx		0x0008	
	Write 0016 Words 4xxxx		0x0010	
	Write 0032 Words 4xxxx		0x0020	
	Write 0064 Words 4xxxx		0x0040	
	Write 0128 Words 4xxxx		0x0080	

- The submodule descriptions for the free protocol are shown in the table below.

Type	SubmoduleName	SubmoduleNumber		Unit
		Submodule Type	SubmoduleSize	
Input data	Free-Port Input 001 Words	0x0031	0x0001	Word
	Free-Port Input 002 Words		0x0002	
	Free-Port Input 004 Words		0x0004	
	Free-Port Input 008 Words		0x0008	
	Free-Port Input 016 Words		0x0010	
	Free-Port Input 032 Words		0x0020	
	Free-Port Input 064 Words		0x0040	
	Free-Port Input 128 Words		0x0080	
Output data	Free-Port Output 001 Words	0x0032	0x0001	Word
	Free-Port Output 002 Words		0x0002	
	Free-Port Output 004 Words		0x0004	
	Free-Port Output 008 Words		0x0008	
	Free-Port Output 016 Words		0x0010	
	Free-Port Output 032 Words		0x0020	
	Free-Port Output 064 Words		0x0040	
	Free-Port Output 128 Words		0x0080	
Control and status	Control Status Module	0x0030	0x0001	The PDO input data of this submodule is 7 bytes, and the output data is 3 bytes. Special handling is required. (The data cannot be processed based on the PDO size in the submodule number.)

7 Technical Specifications

Mechanical specifications

Item	Specification
IP rating	IP20
Dimensions (W x H x D)	24 mm x 100 mm x 75 mm
Weight	Approx. 89 g

Power supply specifications

Item	GL20-2S485	GL20-2S485-MDB
Rated bus input voltage	5 VDC (4.75 VDC to 5.25 VDC)	
Rated bus input current	155 mA (typical@5 V)	
Rated terminal input voltage	None	
Rated terminal input current	1000 mA	None
Rated terminal output voltage	None	
Rated terminal output current	None	
Module hot-swap	Not supported	

Serial port specifications

Item	GL20-2S485	GL20-2S485-MDB
Input PDO data size	Max. 60 bytes	Max. 480 bytes
Output PDO data size	Max. 60 bytes	Max. 480 bytes
Terminal type	DB9 female connector	
Number of channels	2 channels	
Communication port	RS485	
Communication mode	One pair of differential signals (half-duplex)	
Baud rate	4800 bps, 9600 bps (default), 19200 bps, 38400 bps, 57600 bps, and 115200 bps	
Data bit	7 or 8 bits. Default: 8 bits. 7-bit data must not be set to no parity. Otherwise, a serial port parameter configuration error will be reported.	
Start bit	1 bit	
Stop bit	1 bit or 2 bits. Default: 1 bit.	
Parity bit	Odd parity, even parity, no parity; default: no parity.	
Communication data refresh mode	Free refresh	
Number of slaves	Up to 31 slaves per port	
Communication distance	The maximum communication distance is 1200 m. The higher the speed, the smaller the distance.	
Isolated or not	Yes. Channels are isolated from the internal circuit, but not from each other.	
Termination resistor	None. When the module is located at either end of the network, an external termination resistor may be added.	
Independent channel enable	Supported	-

Item	GL20-2S485	GL20-2S485-MDB
Diagnostic reporting function	Supported	
Supported mode	-	Modbus RTU master/slave station, free protocol
Character interval	-	Frame interval detection time when receiving messages. Range: 35 to 10000. Default value: 35. Unit: 0.1 characters.
Response timeout	-	Maximum time the master waits for a response from the slave. Range: 10 to 65535. Default value: 1000. Unit: ms.
Polling delay	-	Delay between the master receiving a response from the slave and sending the next command. Range: 0 to 65535. Default value: 100. Unit: ms.
Action upon read timeout	-	Retain the last input value or clear the input value. Default value: Retain the last input value.
Module control enable	-	When control over Modbus read/write commands is required, select "Enable" mode. The commands can then be controlled by adjusting the value of "module control output". Default value: Disabled.
Module control method	-	This value is only effective in module control enable mode. Default value: Level triggered.
Slave ID	-	Range: 1 to 247. Default value: 1. This parameter is only valid in slave mode.
Response delay	-	The time during which the slave station sends the response message to the master station after receiving query message. Range: 0 to 65535. Default value: 50. Unit: ms. This parameter is only valid in slave mode.
Maximum number of modules mounted to GL20-RTU-PN communication interface module	-	4 Note: The modules must be mounted in the first four slots of the GL20-RTU-PN communication interface module.
Maximum number of modules mounted to GL20-RTU-ECT32 communication interface module	-	4 Note: The modules must be mounted in the first four slots of the GL20-RTU-ECT32 communication interface module.

8 Environmental Specifications

Item	Specification
Installation/Operating environment	Free from conductive dust, conductive fibers, explosive dust, flammable gases, water mist/greasy dirt, corrosive dusts/gases, strong vibration, and repetitive shock
Altitude	≤ 2000 m
Pollution degree	Level 2
Immunity	2 kV on power supply line (Conforms to IEC 61000-4-4)
Overvoltage category	I
EMC immunity level	Zone B, IEC61131-2
Anti-static rating	Contact discharge +/-6 kV and air discharge +/-8 kV
Vibration resistance	<ul style="list-style-type: none"> • Application scenario: Tested according to IEC60068-2-6. 3.5 mm amplitude at 5 Hz to 8.4 Hz; 1 g acceleration at 8.4 Hz to 200 Hz; 10 cycles per axis. • Transportation scenario: Tested according to IEC60068-2-64, 0.01 g²/Hz power spectral density at 5 Hz to 100 Hz; 0.001 g²/Hz power spectral density at 200Hz; 1.14 g G_{rms}
Shock resistance	Application/Transportation scenario: Tested according to IEC60068-2-27; 15 g peak acceleration, 11 ms pulse width, 18 shocks in total in X, Y and Z axes
Operating temperature/humidity	<ul style="list-style-type: none"> • Temperature: -20°C to +55°C • Humidity: < 95% RH (30°C), without condensation
Storage temperature/humidity	<ul style="list-style-type: none"> • Temperature: -20°C to +60°C • Humidity: < 95% RH (30°C), without condensation
Transportation temperature/humidity	<ul style="list-style-type: none"> • Temperature: -40°C to +70°C • Humidity: < 95% RH (40°C), without condensation

9 Dimension Drawing

The dimensions (in mm) are shown in the figure below.

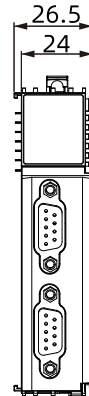
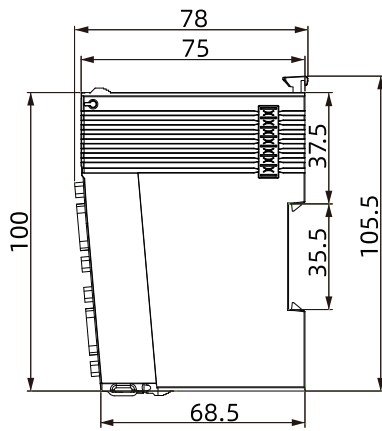

Maintain a minimum 10 mm clearance above the product to ensure full latch travel.

DIN rail mounting position: 5 mm below product center

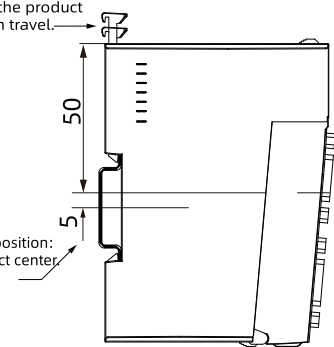

Service and Support

Should you encounter a safety accident during the use or operation of the product, or face challenges in operating and maintaining the equipment, which remain unresolved after the relevant documentation is consulted, we provide multiple channels to ensure prompt resolution:

- Channel #1: Contact service@inovance.com.
- Channel #2: Visit <https://www.inovance.com/global> to access document downloads, after-sales support, spare parts ordering, repair applications, and authenticity verification services.
- Channel #3: Download My Inovance app (<https://zshc-eu.inovance.com/download-pc/>) where you can access products info and documentation, and query product parameters.

We are committed to providing you with quick and professional technical support, and we look forward to your satisfaction and trust.



PS00021937A01

Copyright © Shenzhen Inovance Technology Co., Ltd.

Importa y distribuye en Argentina:

ECFA

ECFA S.R.L.

 Av. San Juan 4063 (C1233ABK) - Buenos Aires - Argentina

 +54 11 4923-6566

 ventas@ecfa.com.ar

 <https://www.ecfa.com.ar>

Shenzhen Inovance Technology Co., Ltd.

www.inovance.com

Add.: Inovance Headquarters Tower, High-tech Industrial Park,
Guanlan Street, Longhua New District,
Shenzhen 518000, P.R. China

Tel: (0755) 2979 9595

Fax: (0755) 2961 9897

Suzhou Inovance Technology Co., Ltd.

www.inovance.com

Add.: No. 52, Tian E Dang Road, Wuzhong District, 215104,
Suzhou City, Jiangsu Province, P.R. China

Tel: (0512) 6637 6666

Fax: (0512) 6285 6720