

INOVANCE

Importa y distribuye en Argentina:

ECFA

H1U Series PLC



Economical & simple to use



- Built-in high-speed output ports (3x 100 kHz)
- Windows-based easy programming tool
- Built-in multiple communication ports; program download/upload supported via serial & USB ports
- Operation in high ambient temperatures – up to 55°C





Features & functions

- PLC module with integrated power supply and I/Os
- 100 ns execution time per single, basic instruction
- Program capacity: 16K steps
- Device memory
 - Auxiliary relays 3,584 points
 - Timers 256 points
 - Counters 256 points
 - Data registers 8,528 points
- High speed inputs: up to 60 kHz
- High speed outputs: up to 100 kHz
- Supports Modbus-RTU (RS422/RS485 ports) and CANlink (Inovance proprietary) communication
- Up to 36 digital inputs and 24 digital outputs
- Programming language conforms to IEC 61131-3:
 - Ladder diagram (LD)
 - Instruction list (IL)
 - Sequential function chart (SFC)

General specifications

PLC model C€		H1U-0806MT-XP	H1U-0806MR-XP	H1U-1410MT-XP	H1U-1410MR-XP	H1U-1614MT-XP	H1U-1614MR-XP	H1U-2416MT-XP	H1U-2416MR-XP	H1U-3624MT-XP	H1U-3624MR-XP
Dimensions ^[5]	Height	[H]: 90 mm		[H]: 90 mm		[H]: 90 mm		[H]: 90 mm		[H]: 90 mm	
	Width	[W]: 70 mm		[W]: 93 mm		[W]: 110 mm		[W]: 133 mm		[W]: 179 mm	
	Depth	[D]: 75 mm		[D]: 75 mm		[D]: 75 mm		[D]: 75 mm		[D]: 75 mm	
Local extension I/O		CANlink (H1U-CAN-BD), RS232 (H1U-232-BD), 2x AI & 2x AO (H1U-4A-BD)									
Power supply		1 ph 85 - 264 Vac									
Built-in inputs	Total inputs	8		14		16		24		36	
	High-speed inputs	2x 60 kHz ^[1] 4x 10 kHz ^[2]									
Built-in outputs	Total outputs	6		10		14		16		24	
	High-speed outputs	3x 100 kHz ^[3]	N/A	3x 100 kHz ^[3]	N/A	3x 100 kHz ^[3]	N/A	3x 100 kHz ^[3]	N/A	3x 100 kHz ^[3]	N/A
	Output type	Transistor (sink/NPN)	Relay ^[4]	Transistor (sink/NPN)	Relay ^[4]	Transistor (sink/NPN)	Relay ^[4]	Transistor (sink/NPN)	Relay ^[4]	Transistor (sink/NPN)	Relay ^[4]
Built-in ports	Serial port	COM0 (RS422/RS485), COM1 (RS485), Modbus-RTU									
	CAN port	CANlink									
	Ethernet port	N/A									
	USB (device)	Mini-B									

Note:

[1] The maximum frequency of the X0 and X1 inputs is 60 kHz. Total added frequency of all inputs cannot exceed 70 kHz

[2] The maximum frequency of the X2 to X5 inputs is 10 kHz. Total added frequency of all inputs cannot exceed 70 kHz

[3] The maximum frequency of the Y0 to Y2 outputs is 100 kHz

[4] Maximum output current:

• Resistive load: 2 A/1 point (maximum current of the common terminal is 8 A) · Inductive load: AC 220 V, 80 VA · Lamp load: AC 220 V, 100 W

[5] Refer to dimensions (see following page)

Dimensions

Mounting dimensions diagram

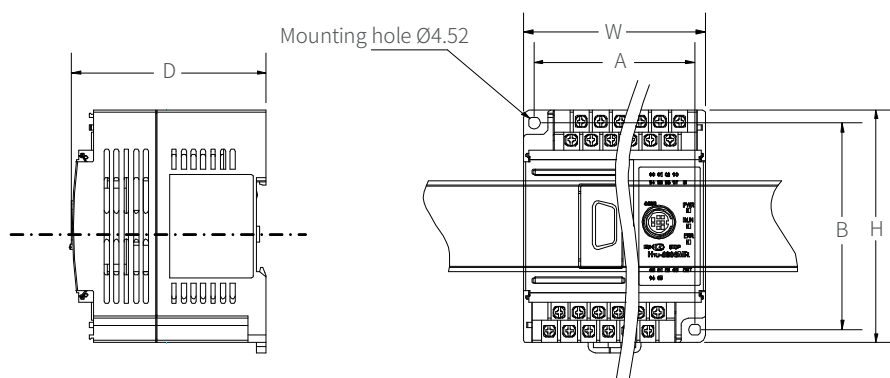

Model	Mounting dimensions	
	A (mm)	B (mm)
H1U-0806MR/T	62	80
H1U-1410MR/T	83	80
H1U-1614MR/T	100	80
H1U-2416MR/T	123	80
H1U-3624MR/T	169	80

Product overview

H1U-XXXXMR/T-XP

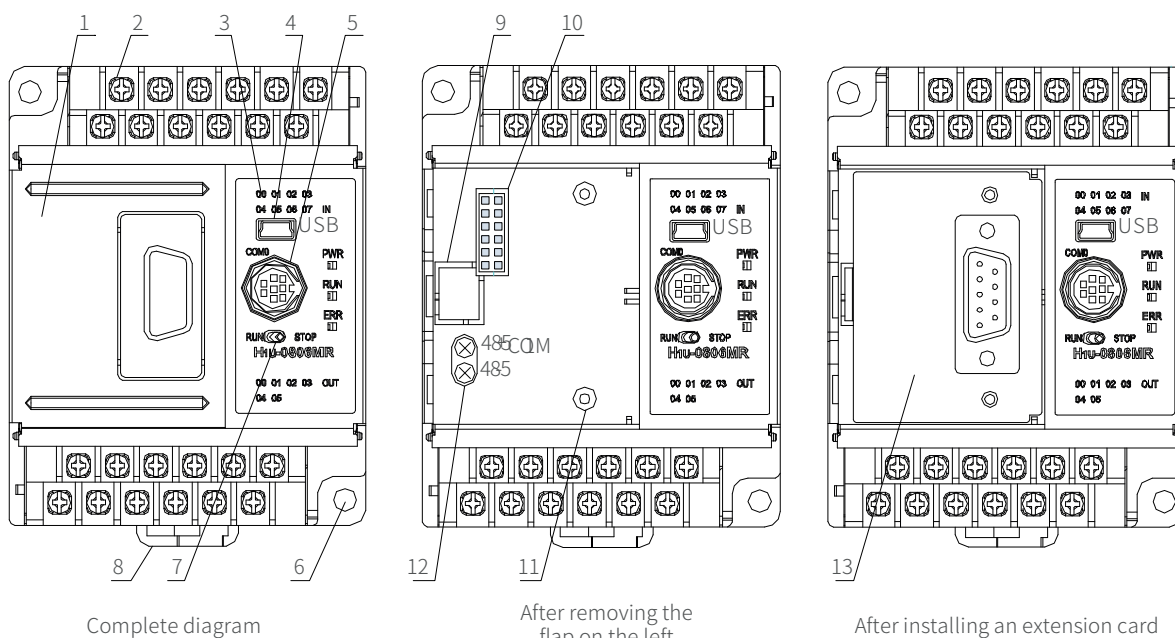

Complete diagram

After removing the flap on the left

After installing an extension card

Component names	Function description
1)	Removable flap
2)	Power supply, auxiliary power supply and detachable terminals for signal input
3)	Indicator LEDs
4)	USB port
5)	User program download port (COM0)
6)	Screw holes (two)
7)	RUN/STOP switch
8)	Buckle for two DIN rail mountings
9)	System program port (user's operation is prevented here.)
10)	Special function extension card interface
11)	Special function extension card fixing bolts (screw specification: M2.6x6)
12)	Wiring terminal for RS485 communication port
13)	Special function extension card (an optional accessory)

Product overview

Accessory	Type code	Part no.	Product description
Extension cards ¹	H1U-CAN-BD	01023011	CANlink communication extension card
	H1U-232-BD	01023017	RS232 communication extension card
	H1U-4A-BD	01023019	2 analog voltage/current inputs and 2 analog voltage outputs extension card
Cables	H2U-232-CAB	15042148	For connection between IT6000/IT7000 HMIs (DB9 female connector) and H1U controller (DIN8 connector), length of 2m
	H2U-USB-CAB	15041200	USB programming cable for connection between PC (USB type A connector) and H1U controller (USB mini B connector), length of 1.5m
	IT5-H2U-CAB	15041140	For connection between IT6000/IT7150E HMIs (DB9 male connector) and H1U controller (DIN8 connector), length of 3m. *Not usable with IT7070_/IT7100_
	IT7-H3U-CAB	1504AX53	For connection between IT7070_/IT7100_ HMIs (DB9 female) and H1U controller (DIN8 connector). *Not usable with IT7150E

H1U - application topology

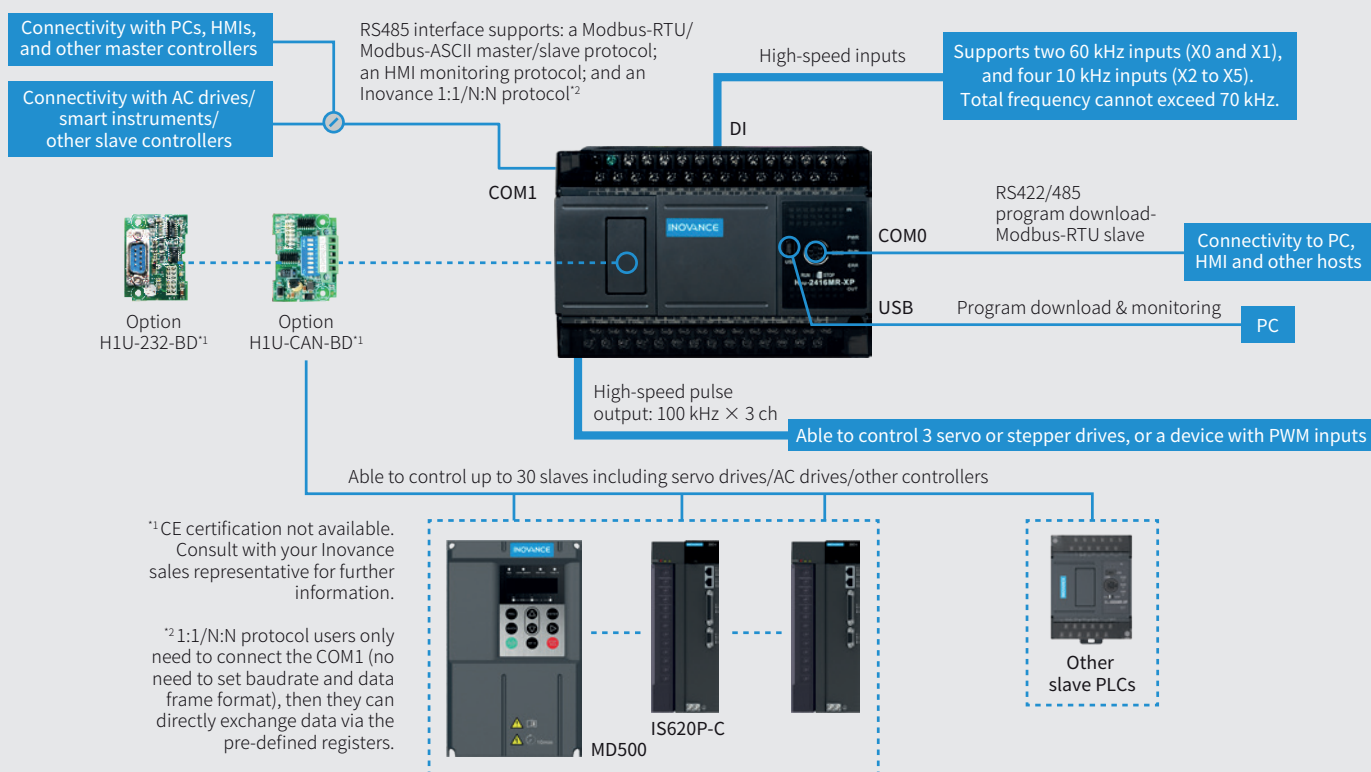

Importa y distribuye en Argentina:

ECFA

ECFA S.R.L.

Av. San Juan 4063 (C1233ABK) - Buenos Aires - Argentina

+54 11 4923-6566

ventas@ecfa.com.ar

https://www.ecfa.com.ar

INOVANCE