

INOVANCE

Advancing industrial technology,
for a better world

Importa y distribuye en Argentina:

ECFA



Easy52X Series Programmable Logic Controller User Guide



Industrial
Automation



New Energy
Vehicle



Intelligent
Elevator



Intelligent
Robot



Digital
Energy



Rail
Transit



Data code P500005506A08

Legal Information

■ Copyright

Copyright © 2022 Shenzhen Inovance Technology Co., Ltd. All rights reserved.

This documentation is the exclusive property of Shenzhen Inovance Technology Co., Ltd. No individual or entity may excerpt, reproduce, modify, translate, or distribute any content herein without written consent from Inovance.

Legal action will be taken against infringement.

■ Trademarks

INOVANCE is a registered trademark of Shenzhen Inovance Technology Co., Ltd. and its affiliates. All other trademarks or registered trademarks mentioned in this documentation are the property of their respective owners. Unauthorized use of these trademarks by third parties for any purpose without written authorization could violate the rights of their owners.

■ Disclaimer of Liability

Due to continuous updates and improvements of products and technologies, the content of this documentation may not fully match the actual products. In the event of any discrepancies, the actual products shall prevail.

The contents are subject to change without notice due to product upgrade.

■ Waste Disposal

The storage, use, and disposal of this product (including optional accessories) must comply with local laws and regulations.

■ Qualified Personnel

The product/system described in this documentation may be operated only by personnel qualified for the specific task in accordance with the relevant documentation, in particular its warning notices and safety instructions. Qualified personnel can identify the risks of the product/system and prevent possible dangers.

■ Proper Use of the Product

Proper transportation, storage, assembly, installation, commissioning, operation, and maintenance are required to ensure the safe operation of the product without any problems. The required ambient conditions must be met. All operations must follow the guidelines provided in this documentation.

Preface

■ Introduction

This product is a new generation of small-sized programmable logic controller (PLC) independently developed by Inovance. It supports EtherCAT bus control and network switching over dual network ports. It allows process encapsulation and reuse through the Function Block (FB) and Function (FC) features, and supports multi-layer network communication through the RS485, Ethernet, and EtherCAT ports. This product can accommodate a maximum of 16 expansion modules. For module types supported, see the section "Local Expansion Modules" in the "H5U and Easy Series Programmable Logic Controller Programming Guide". This product can also provide the RS485, RS232, CAN, digital input (DI), digital output (DO), analog input (AI), analog output (AO), real-time clock (RTC), and trans-flash (TF) card features through expansion cards.

This guide describes the installation and wiring of the product, including product information, mechanical installation, and electrical installation.

■ Compliance

The following table lists the certifications, directives, and standards applicable to this product. For certifications actually acquired for the product you purchased, see the certification marks on the product nameplate.

Certification	Directive		Standard
CE	EMC	2014/30/EU	24 VDC products: EN 61131-2 220 VAC products: EN 61131-2 EN 61000-3-2 EN 61000-3-3
	LVD	2014/35/EU	EN 61010-1 EN 61010-2-201
	RoHS	2011/65/EU amended by (EU) 2015/863	EN IEC 63000
UL/cUL	-		UL 61010-1 UL 61010-2-201 CAN/CSA-C22.2 No. 61010-1 CSA C22.2 NO. 61010-2-201
KCC	-		-
EAC	-		-
UKCA	Safety Regulations	Electrical Equipment (Safety) Regulations 2016	EN 61010-1 EN 61010-2-201
	EMC Regulations	Electromagnetic Compatibility Regulations 2016	24 VDC products: EN 61131-2 220 VAC products: EN 61131-2 EN 61000-3-2 EN 61000-3-3
	RoHS Regulations	Directive (RoHS) Regulations 2012	EN IEC 63000

■ More Data

Data Name	Data Code	Description
GE20 Series Expansion Card User Guide	PS00006443	Describes the product information, installation and wiring, and programming examples of the GE20 series expansion card.
H5U and Easy Series Programmable Logic Controller Programming Guide	19012249	Describes the basics of PLC programming, quick start guide, communication, motion control, and high-speed counter usage.
H5U and Easy Series Programmable Logic Controller Instruction Guide	19012250	Describes the basic instructions and complex instructions used for programming applications, as well as examples of these instructions.
Easy52X Series Programmable Logic Controller User Guide (this guide)	PS00005506	Describes the installation and wiring of the product, including product information, mechanical installation, and electrical installation.

■ Revision History

Date	Version	Description
January 2026	A08	Updated effect diagrams and the product code.
September 2025	A07	Updated module restrictions for non-horizontal installation in "3.1 Installation Environment" on page 23
March 2025	A06	Modified input and output terminal wiring diagrams in "4.2 Terminal Wiring" on page 33
January 2025	A05	Corrected minor errors.

Date	Version	Description
July 2024	A04	<p>New</p> <p>Added the I/O terminal wiring in "4.2 Terminal Wiring" on page 33</p> <p>Modify</p> <ul style="list-style-type: none"> • Updated the note for power-off and restart in "2.2 Components" on page 14 • Updated the program data capacity in "2.3.1 General Specifications" on page 18 • Updated the number of axes supported in "2.3.1 General Specifications" on page 18 • Updated the rated current of bus input power for the GL20-3232ETN-M expansion module in "2.3.2 Power Supply Specifications" on page 19
February 2024	A03	<p>New</p> <ul style="list-style-type: none"> • Added the PNP model in "2.1 Model and Nameplate" on page 13 • Added the PNP specifications in the high-speed input item in "2.3.1 General Specifications" on page 18 • Added the PNP specifications in the high-speed input (X0 to X7) item in "2.3.3 Input Specifications" on page 20 • Added the PNP specifications in the output type item in "2.3.4 Output Specifications" on page 21 • Added the PNP output terminal wiring in "4.2 Terminal Wiring" on page 33 • Added the Easy52X programmable controller models and the GL20 expansion module models in "Appendix" on page 60 <p>Modify</p> <ul style="list-style-type: none"> • "2.2 Components" on page 14 Updated the descriptions of status indicators in • Updated the power supply specifications in "2.3.2 Power Supply Specifications" on page 19
March 2023	A02	Updated the diagram of DIN rail buckles and added some product specification data.

Date	Version	Description
October 2022	A01	<ul style="list-style-type: none"> • Added support for CAN communication. • Corrected minor errors.
August 2022	A00	Initial release.

■ Access to the Guide

This guide is not in the scope of delivery. If necessary, you can download the PDF file in the following ways:

- Visit <https://www.inovance.com/global> and choose Service&Support > Support > Documentation Download.
- Scan the QR code on the product with your smart phone to obtain the corresponding guide.
- Scan the QR code below to install My Inovance app, where you can search for and download user guides.



■ Warranty Disclaimer

If your product becomes defective under normal use conditions, we will offer guaranteed repair services within the warranty period. Maintenance will be charged after the warranty period expires.

Even in the warranty period, a maintenance fee will be charged for repair of the following damage:

- Damage caused by operations not following the instructions in the guide
- Damage caused by fire, flood, or abnormal voltage
- Damage caused by unintended use of the product
- Damage caused by use beyond the specified scope of application of the product
- Damage or secondary damage caused by force majeure (such as natural disaster, earthquake, and lightning strike)

The maintenance fee will be charged according to our latest Price List if not otherwise agreed upon.

For details, see the Product Warranty Card.



1 Fundamental Safety Instructions

1.1 Fundamental Safety Instructions

■ Safety Disclaimer

1. Read the safety precautions before installing, operating, and maintaining this product.
2. To ensure personal and equipment safety, follow all safety precautions marked on the product and described in the user guide when installing, operating, and maintaining this product.
3. "CAUTION", "WARNING", and "DANGER" messages in the guide are only examples and do not cover all safety precautions.
4. Use this product in an environment that complies with the design specifications. Malfunction or component damage caused by improper use is not covered by warranty.
5. Inovance shall not be liable for any physical injuries or property loss caused by improper use.

■ Safety Levels and Definitions

-  **DANGER** "DANGER" indicates that failure to comply with the notice will result in severe physical injuries or even death.
-  **WARNING** "WARNING" indicates that failure to comply with the notice may result in severe physical injuries or even death.
-  **CAUTION** "CAUTION" indicates that failure to comply with the notice may result in minor or moderate physical injuries or equipment damage. Keep this guide properly for future reference and forward it to the end user.

Control System Design



- Design a safety circuit to ensure that the control system can still work safely upon an external power outage or programmable controller failure.
- The product may catch fire or emit smoke in case of prolonged overcurrent due to overload or short circuit of load. Therefore, configure an external safety device such as a fuse or circuit breaker.



WARNING

- Design an external emergency stop circuit, protective circuit, forward and reverse rotation interlock circuit, as well as up and down limit interlock circuit to be connected to the programmable controller.
- Design an external protective circuit and a safety mechanism for output signals that may cause major incidents.
- When the programmable controller CPU detects a system exception, it may turn off all outputs. When partial circuit of the controller malfunctions, the controller outputs may become uncontrollable. To ensure proper operation, it is necessary to design an appropriate external control circuit.
- If a programmable controller output unit such as the relay or transistor is damaged, its output cannot be controlled to turn ON or OFF.
- The programmable controller is intended for use in an indoor electrical environment with an overvoltage class of II. The power system must contain a lightning arrester to prevent lightning from causing overvoltage on the power supply input, signal input, and control output terminals of the programmable controller and damaging the equipment.

Installation



WARNING

- Only allow trained professionals with electrical expertise to install this product.
- Cut off all external power sources before you install or remove this product. Failure to comply may result in electric shock or faults or malfunctions of this product.
- Do not use the programmable controller in places with dirt, oily fume, conductive dust, corrosive gas, flammable gas, high temperature, condensation, wind and rain, vibration, or shock. Electric shock, fire, and improper operation will lead to damage and deterioration of the product.
- The controller is open-type equipment that must be installed in a control cabinet with lock (IP rating of the control cabinet enclosure > IP20). Only qualified professionals can open the cabinet.



CAUTION

- During installation, prevent metal chippings and cable ends from falling into the vent of the product. Failure to comply may result in fire, faults, or malfunctions.
- After installation, ensure that no unwanted objects exist on the ventilation surface. Failure to comply may result in poor heat dissipation, fire, faults, or malfunctions.
- During installation, tightly connect the product and its connectors and firmly lock its hooks. Improper module installation may lead to malfunctions, faults, and detachment.

Wiring



DANGER

- Only allow trained professionals with electrical expertise to conduct wiring for this product.
- Cut off all external power sources before wiring. Failure to comply may result in electric shock or equipment faults or malfunctions.
- Properly insulate the cable terminals and ensure a proper insulation distance between the cables connected to the terminal block. Failure to comply will result in electric shock or equipment damage.



CAUTION

- Turn off the main power supply before connecting it to the product. Failure to comply may result in electric shock.
- Select a proper power supply according to the power supply specifications of the product in the "Technical Specifications" section. If the selected power supply is beyond the required range, the product may be damaged. Regularly check whether the DC power provided by the switching-mode power supply unit is stable.

Operation and Maintenance



CAUTION

- Only allow trained professionals with electrical expertise to operate and maintain this product.
- Do not touch terminals when the power is on. Failure to comply may result in electric shock or malfunctions.
- Cut off all external power sources before you clean the product. Failure to comply may result in electric shock.
- Cut off all external power sources before you install and remove modules and communication cables. Failure to comply may result in electric shock or malfunctions.

Safety suggestions

- In places where operators have direct contact with mechanical parts, such as loading and unloading places and areas with automatic machinery operation, carefully configure an on-site manual operating device or alternative means that works independently of the programmable controller and can start or stop the automatic operation.
- If programs need to be modified when the system is running, apply a lock or take other necessary measures to ensure that only authorized personnel can perform such modification.

Disposal



- Dispose of this product as industrial wastes. Dispose of the battery separately in accordance with local laws and regulations.
- Recycle retired equipment by observing industry waste disposal standards to avoid environmental pollution.

1.2 Industrial Information Security

This product provides an interface to connect to the network and transmit data through the network interface. To protect factories, systems, machines, and networks from cyber attacks, appropriate industrial information security protection mechanisms need to be implemented to ensure the safe operation of factories, systems, machines, and networks.

The customer is responsible for providing and continuously ensuring a secure connection between the product and the customer's network or any other network, to prevent unauthorized access to their factory, systems, machines, and networks. The system or machine may only be connected to the corporate network or the Internet when a secure connection is established and proper security measures are in place (for example, using antivirus software and installing firewalls).

INOVANCE continuously develops and improves its products and solutions to enhance safety. It is strongly recommended that you update your products promptly and always use the latest product versions.



Malware (such as viruses, Trojans, and worms) can bring the device into an unsafe operating state, resulting in death, serious injury, and property damage. Observe the following precautions strictly:

- Always use the latest software version. If the product version is no longer supported or the latest program version is not applied, customers are at increased risk of cyberattacks.
 - Implement and maintain appropriate security measures (including but not limited to deploying anti-virus software, firewall, WAF, IPS/IDS, situational awareness system, ID verification, and data encryption) to prevent files in the removable storage device from being damaged by malware and to protect products, networks, systems, and interfaces from unauthorized access, disruption, intrusion, data leakage, or information theft.
 - Check all safety-related interfaces and settings after commissioning.
-

2 Product Information

2.1 Model and Nameplate

■ Model description

Easy 52X – 0808 TX

① ② ③ ④

<p>① Product series Easy: Easy series programmable logic controller</p>	<p>③ Number of inputs/outputs 08: 8 inputs 08: 8 outputs</p>
<p>② Model code 5: 500 series platform 2: 2 Ethernet ports X: Number of EtherCAT axes, 1 indicating 8 axes, 2 indicating 16 axes, and 3 indicating 32 axes</p>	<p>④ Output type X: N or P TN: Sink-type transistor TP: Source-type transistor</p>

■ Nameplate description

Easy523-0808TN

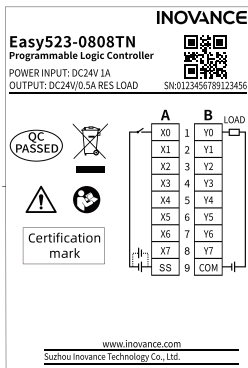

Easy523-0808TP

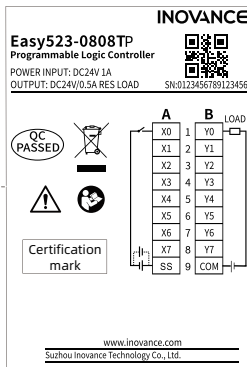

Model	Description	Code
Easy521-0808TN-INT	Easy500 series 8-input 8-output 8-axis programmable controller	01441173
Easy522-0808TN-INT	Easy500 series 8-input 8-output 16-axis programmable controller	01441188
Easy523-0808TN-INT	Easy500 series 8-input 8-output 32-axis programmable controller	01441208
Easy521-0808TP-INT	Easy500 series 8-input 8-output 8-axis programmable controller	01441160
Easy522-0808TP-INT	Easy500 series 8-input 8-output 16-axis programmable controller	01441210
Easy523-0808TP-INT	Easy500 series 8-input 8-output 32-axis programmable controller	01441206

2.2 Components

The Easy52X-0808TN and Easy52X-0808TP models share the same components. The following section takes the Easy523-0808TN model as an example to describe the components.

No.	Type	Mark	Definition	Indicator Color	Description
①	I/O indicator	IN/OUT	I/O status	Yellow-green	<ul style="list-style-type: none"> ● Steady ON: Input or output active ● OFF: Input or output inactive
②	Operation status indicator	PWR	Power supply	Yellow-green	<ul style="list-style-type: none"> ● Steady ON: Power supply normal ● OFF: Power supply off or abnormal
		RUN	Normal running	Yellow-green	<ul style="list-style-type: none"> ● Steady ON: User program running ● OFF: User program stopped
		ERR	Running error	Red	<ul style="list-style-type: none"> ● OFF: No major error ● Blinking^[1]: Major error occurred
		ETH1	Ethernet link 1	Yellow-green	<ul style="list-style-type: none"> ● Steady ON: Connected ● Blinking: Communication in progress ● OFF: Disconnected
		ETH2	Ethernet link 2	Yellow-green	<ul style="list-style-type: none"> ● Steady ON: Connected ● Blinking: Communication in progress ● OFF: Disconnected
③	DIP switch	RUN/STOP	Run/Stop control	-	-
④	Type-C port		Communication with PC	-	-
⑤/⑥	Expansion card slot	01/02	Expansion card slots, used to expand features	-	Expansion card options are available in " Appendix " on page 60

No.	Type	Mark	Definition	Indicator Color	Description
⑦	RS485	485+	Positive of RS485 communication signal	-	-
		485-	Negative of RS485 communication signal	-	-
		GND ^[2]	RS485 communication ground	-	-
⑧	Power supply port	+24V	24 VDC power supply positive	-	-
		0V	24 VDC power supply negative	-	-
			Function grounding ^[2]	-	-
⑨	EtherCAT port	EtherCAT	EtherCAT communication ^[2]	-	PoE power supply not supported
⑩	I/O terminal	-	8-channel input and 8-channel output	-	For details, see "4.1 Terminal Layout" on page 32
⑪/⑫	Ethernet port	EtherNET1/ EtherNET2	RJ45 ports used for Ethernet communication	-	PoE power supply not supported



Caution

- [1]: To restart the product in case of a fault, turn off the power and disconnect the USB cable. Ensure the power indicator is off for at least 10 seconds before powering it on again.
- [2]: Do not connect the PE cable to the GND terminal.
- The EtherCAT communication cable model is the same as the servo communication cable model, such as S6-L-T04-3.0.

2.3 Product Specifications

2.3.1 General Specifications

Item	Easy521-0808TX	Easy522-0808TX	Easy523-0808TX
Program data capacity	<ul style="list-style-type: none">• User program: 400 kB• User-defined variables: 2 MB, 128 kB of which is retentive at power failure• Soft elements: Approx. 150 kB (retentive at power failure after No. 1000; non-retentive at power failure when the PLC is only powered by USB)		
Instruction execution speed	20 k-step in 1.6 ms		
Bit operation	0.113 μ s/instruction		
Word transmission	0.232 μ s/instruction		
Floating point operation	0.578 μ s/instruction		
Ethernet	Support Ethernet/IP, ModbusTCP (up to 32 slaves), Socket, PROFINET slaves, FINS TCP/FINS UDP slaves, program download/upload, and firmware upgrade.		
EtherCAT communication	Supports 1 EtherCAT master with up to 72 EtherCAT slaves.		

Item	Easy521-0808TX	Easy522-0808TX	Easy523-0808TX
Number of axes (pulse + EtherCAT bus)	Up to 8 EtherCAT bus axis: 8; profile axis: 8; local pulse axis: 5; virtual axis: 16	Up to 16 EtherCAT bus axis: 16; profile axis: 16; local pulse axis: 5; virtual axis: 16	Up to 32 EtherCAT bus axis: 32; profile axis: 32; local pulse axis: 5; virtual axis: 32
Serial communication	Up to 3 channels (1 on the PLC and 2 through expansion cards) Note: Serial communication is provided by GL20-2S485 and GL20-2SCOM expansion modules with serial ports.		
CAN communication	One master (requiring firmware version 5.66.0.0 or later and AutoShop version 4.8.0.0 or later) <ul style="list-style-type: none"> • CANlink: Up to 62 slaves • CANopen: Up to 30 slaves with 16 axes 		
High-speed input	<ul style="list-style-type: none"> • Easy52X-0808TN: 8-channel at 200 kHz (single-phase) • Easy52X-0808TP: 8-channel at 100 kHz (single-phase) 		
High-speed output	5 axes at 200 kHz; PWM supported		
Expansion module	Up to 16 local expansion modules		
Expansion card	Up to 2 expansion cards		
Programming language	LD (FB/FC supported), ST, and SFC		
Type-C	<ul style="list-style-type: none"> • Program upload and download and firmware upgrade through Type-C or GE20-TF storage expansion card • Communication distance of 3 m by using a USB cable 		
IP rating	IP20		
Dimensions (W x H x D)	53 mm x 100 mm x 80 mm		
Weight	Approx. 197 g		

2.3.2 Power Supply Specifications

Item	Specification
Rated terminal input voltage	24 VDC \pm 10% (21.6 VDC to 26.4 VDC)
Rated current of terminal input power supply	1 A (max@24 VDC)

Item	Specification
Rated voltage of bus output power supply	5 VDC (4.75 VDC to 5.25 VDC)
Rated current of bus output power supply ^[1]	2 A (typical@5 V)
24 V input power supply protection	Protection against short circuit and reversed polarity connection
Hot swap	Not supported

Note

[1]: Expansion modules are powered by the Easy programmable logic controller. Therefore, the sum of the rated current values of the bus input power for expansion modules must not be greater than the current value specified in the table (≤ 2 A). For example, the rated current of the bus input power for the GL20-3232ETN-M expansion module is 250 mA, so at most eight such modules can be connected to the Easy series programmable logic controller ($2 \text{ A}/250 \text{ mA} = 8$).

2.3.3 Input Specifications

Item	Specification	
Input type	Digital input	
Number of input channels	8	
Input mode	Source/sink	
Input voltage class	24 VDC \pm 10% (21.6 VDC to 26.4 VDC)	
High-speed input (X0 to X7)	Input current at input ON	<ul style="list-style-type: none"> ● Easy52X-0808TN: > 4 mA ● Easy52X-0808TP: > 2.5 mA
	Input current at input OFF	<ul style="list-style-type: none"> ● Easy52X-0808TN: < 2.5 mA ● Easy52X-0808TP: < 1.5 mA
	Hardware response time	2 μ s (RC time)
	Max. input frequency	<ul style="list-style-type: none"> ● Easy52X-0808TN: 200 kHz ● Easy52X-0808TP: 100 kHz
	Input impedance	<ul style="list-style-type: none"> ● Easy52X-0808TN: 3.4 kΩ ● Easy52X-0808TP: 5.7 kΩ
ON voltage	≥ 15 VDC	

Item	Specification
OFF voltage	≤ 5 VDC
Software RC filter time	<ul style="list-style-type: none"> • Low speed: 2 ms to 1000 ms • High speed: 2 μs to 1000 μs
Isolation mode	Capacitive isolation with integrated chips
Common terminal mode	8 points/common terminal (+/- polarity of input power supply reversible)
Input action display	The input indicator turns on (controlled by software) when the input is in drive state.

2.3.4 Output Specifications

Item	Specification	
Output type	<ul style="list-style-type: none"> • TN: NPN transistor output • TP: PNP transistor output 	
Number of output channels	8	
Output voltage class	24 VDC \pm 10% (21.6 VDC to 26.4 VDC)	
High-speed output (Y0 to Y7)	Resistive output load	0.5 A/point; 2 A/8-point
	Inductive output load	7.2 W/point; 24 W/8-point
	Lamp output load	5 W/point, 18 W/8-point
	Hardware response time (ON/OFF)	< 1 μ s (OFF \rightarrow ON); < 2 μ s (ON \rightarrow OFF)
	Load current requirements	Load current \geq 12 mA when used with outputs greater than 10 kHz
	Maximum output frequency	200 kHz for resistive load; 0.5 Hz for inductive load; 10 Hz for lamp load
PWM output	Maximum frequency 200 kHz; minimum pulse width 2.5 μ s; minimum resolution 2.5 μ s; adjustable duty cycle ^[1] 0.01% to 99.99%	
Leakage current upon OFF	< 30 μ A at rated 24 V	
Maximum residual voltage during ON	< 0.5 VDC	
Isolation mode	Digital isolator	

Item	Specification
Common terminal mode	8-point/common terminal (positive/negative polarity of output power being changeable)
Short circuit protection	Protection against short circuit of each channel, recovered after power-off
External inductive load protection	Flywheel diode ^[1] is required when an external inductive load is connected.
Output action display	The output indicator lights up (controlled by software) when the output is in drive state.

[1]: The duty cycle setting is frequency dependent, and the pulse width corresponding to the duty cycle must not be less than the minimum pulse width.

[2]: Use 1N4001 (50 V/1 A) or a similar diode, as marked by D in the following figures.

● **Easy52X-0808TN**

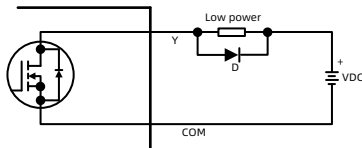

● **Easy52X-0808TP**

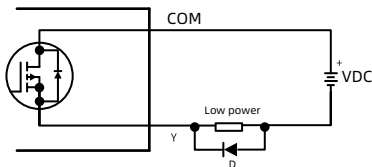

3 Mechanical Installation

3.1 Installation Environment

When installing the PLC on the guide rail, take the operability, maintainability, and environment adaptation into account.

Item	Specification
Operating environment	Free from conductive dust, conductive fibers, explosive dust, flammable gases, water mist/greasy dirt, corrosive dusts/gases, strong vibration, and repetitive shock
Altitude	≤ 2000 m (80 kPa)
Pollution degree	PD2
Noise immunity	2 kV on power cable (IEC 61000-4-4)
Overvoltage category	I
EMC immunity level	Zone B, IEC 61131-2
Anti-static rating	Contact discharge +/-6 kV and air discharge +/-8 kV
Vibration resistance	<ul style="list-style-type: none">● Application scenario: Tested according to IEC 60068-2-6; 3.5 mm amplitude at 5 Hz to 8.4 Hz; 1 g acceleration at 8.4 Hz to 200 Hz; in ten cycles/axes.● Transport scenario: Tested according to IEC 60068-2-64. Test conditions: 5 Hz to 100 Hz, 0.01 g²/Hz; 200 Hz, 0.001 g²/Hz, G_{rms} of 1.14 g, 30 min each in X, Y and Z directions.
Shock resistance	Application scenario: Tested according to IEC 60068-2-27. Test conditions: 15 g peak acceleration, 11 ms pulse width, total 18 shocks in X, Y and Z directions.
Overcurrent protection device	<ul style="list-style-type: none">● Easy301: 1.1 A fuse● Easy302/Easy501/Easy502/Easy52X: 1.5 A fuse
Storage temperature and humidity	<ul style="list-style-type: none">● Temperature: -20°C to +60°C● Relative humidity: < 90%, non-condensing
Transportation temperature and humidity	<ul style="list-style-type: none">● Temperature: -40°C to +70°C● Relative humidity: < 95%, non-condensing

Item	Specification
Operating temperature and humidity	<ul style="list-style-type: none">● Temperature: -20°C to $+55^{\circ}\text{C}$ (for horizontal installation), -20°C to $+45^{\circ}\text{C}$ (for non-horizontal installation)● Relative humidity: $< 95\%$, non-condensing <p>Note: When the ambient temperature exceeds the upper limit, a cooling fan or air conditioner must be installed along the heat dissipation hole direction.</p>

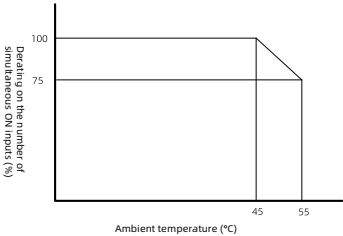
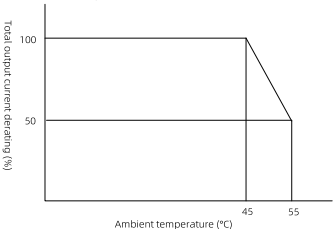
Item	Specification
Installation position and limit	<p>Installation position: The PLC can be installed horizontally, vertically, on the top of the cabinet, or at the bottom of the cabinet.</p> <p>Installation limit:</p> <ul style="list-style-type: none"> ● Horizontal installation: <ul style="list-style-type: none"> ■ Input derating: When the ambient temperature is 45°C, the PLC can work at full load. When the ambient temperature is 55°C, the number of active inputs shall be reduced to 75% (that is, no more than six channels), with a derating rate of 2.5% for temperature rise of every 1°C.  <ul style="list-style-type: none"> ■ Output derating: When the ambient temperature is 45°C, the PLC can work at full load (that is, total current of eight channels not higher than 2 A). When the ambient temperature is 55°C, the total current of active outputs shall be reduced to 50% (that is, total current of eight channels not higher than 1 A), with a derating rate of 5% for temperature rise of every 1°C. 

Item	Specification
Installation position and limit	When installed non-horizontally: The maximum number of inputs should not exceed 6, the maximum output current should not exceed 1 A, and the number of modules should not exceed 6.

3.2 Installation Position

This product can be installed in four positions (modes): horizontal (recommended), vertical, cabinet top, and cabinet bottom. Different modes have different ambient temperature requirements. For details, see ["3.1 Installation Environment" on page 23](#).

■ Optimal installation position

The optimal installation mode is horizontal, adopting natural convection for heat dissipation. To ensure normal ventilation and heat dissipation and sufficient wiring space, sufficient clearance must be reserved around the module, as shown in the following figure.

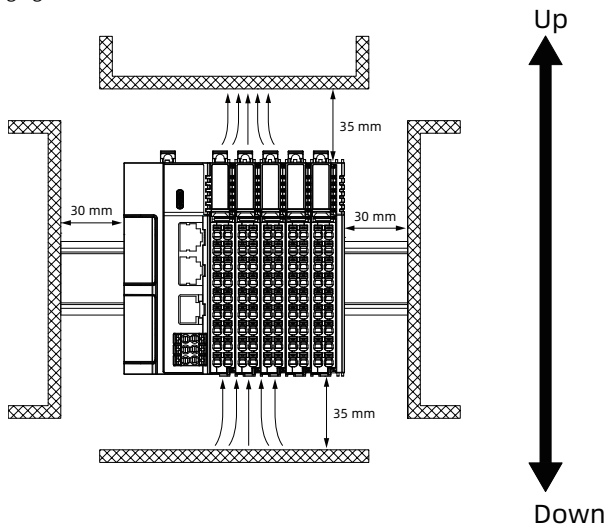

Note

Keep the PLC away from high-temperature heating sources (heater, transformer, large resistor, etc.) by at least 100 mm.

■ Other installation positions

For other installation positions, the same clearance requirements as the optimal installation position apply. Other installation positions are shown in the following figure.

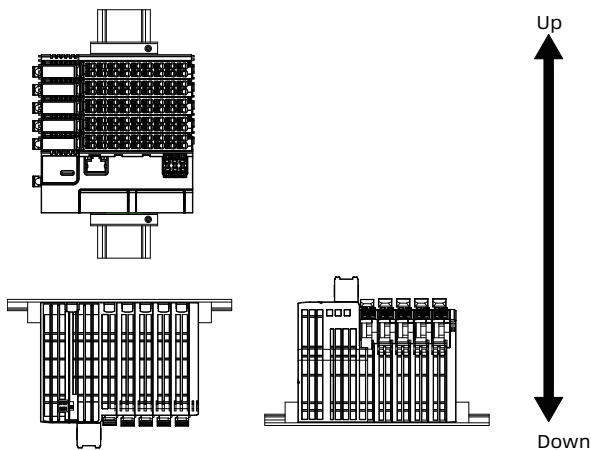



Caution

In case of vertical installation:

- Install the PLC below all I/O modules.
- Hold the cables with a cable duct to prevent the weight of cables being applied to the lower end plate. Failure to comply may cause displacement of the PLC from the DIN rail, leading to maloperation of the PLC.

3.3 Installation Precautions

- Before you install and uninstall the PLC and modules, ensure that they are powered off.
- Do not hot swap the modules. This may lead to restart or damage of the PLC or user data loss.
- To avoid damage to the PLC and modules, prevent the enclosure and terminals of them from falling-off or being impacted.

3.4 Installation Dimensions

The installation dimensions (in mm) are shown in the figure below.

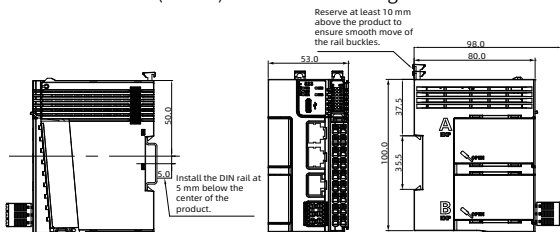

3.5 Installation Method

The DIN rail in compliance with IEC 60715 is used to install the PLC. The following figure shows the dimensions (width of 35 mm and thickness of 1 mm) of the rail.

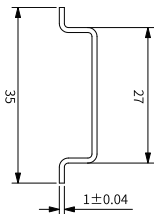

Caution

When installed on a DIN rail other than the recommended one (especially the one whose thickness is not 1.0 mm), the module will not fit in place as the mounting hook does not work.

■ Installing the PLC

1. Align the PLC with the DIN rail and push the PLC towards the direction marked by the arrow until you hear a click sound, as shown in the following figure.

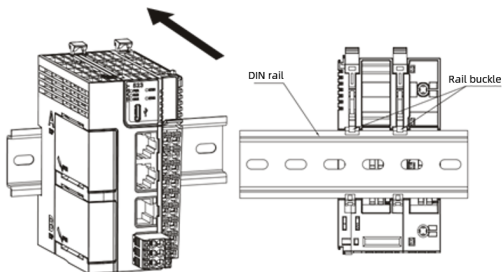

2. Confirm that the DIN rail buckles of the PLC are locked. The following figures show the locked and unlocked states of the buckles.



- The buckles are locked when pressed down.

- The buckles are unlocked when lifted up.
Pressing the buckles locks them.



Keep the mounting hook locked when the controller is not mounted on the rail. If the mounting hook is kept unlocked for an extended period of time, it may malfunction.

■ Inserting modules to the PLC

Modules are slid onto the PLC through the rails on the top and bottom of the modules, as shown in the following figure.

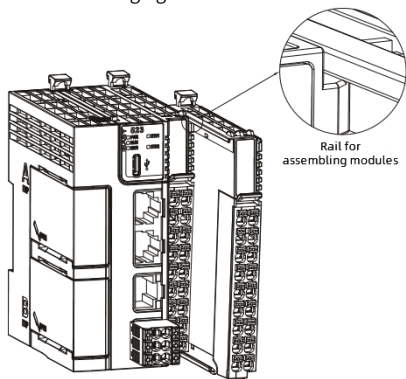

Mount an end plate on a side of the PLC or expansion module. When you install a rail retainer, hook the bottom of the retainer to the bottom of the rail, rotate the retainer to make its top hook the top of the rail, and then tighten the screw to fasten the rail retainer, as shown in the figure below.

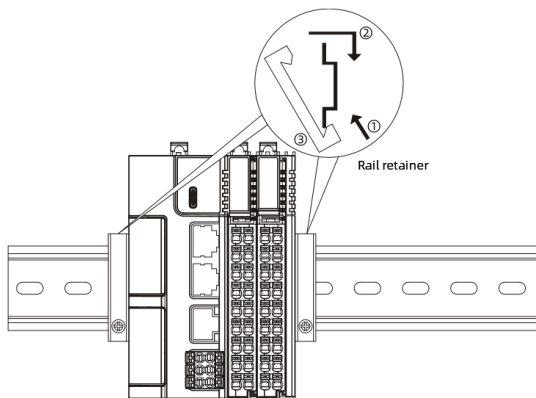

■ Removal

Use a straight screwdriver or similar tool to pry up the rail buckles, pull the module forward, and press the buckles down after the module is pulled out.

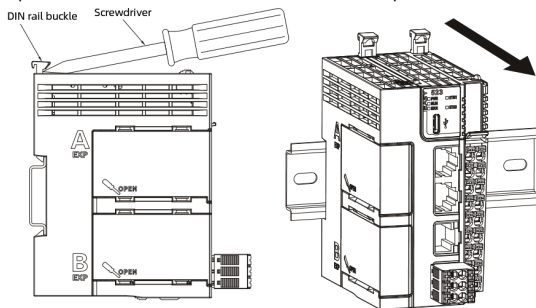

4 Electrical Installation

4.1 Terminal Layout



Left Signal	Left Terminal	Right Terminal	Right Signal
X0 input	A1	B1	Y0 output
X1 input	A2	B2	Y1 output
X2 input	A3	B3	Y2 output
X3 input	A4	B4	Y3 output
X4 input	A5	B5	Y4 output
X5 input	A6	B6	Y5 output
X6 input	A7	B7	Y6 output
X7 input	A8	B8	Y7 output
Input common terminal SS	A9	B9	Output common terminal COM



Caution

- The length of a high-speed I/O interface extension cable must be within 3.0 m.
- To prevent interference, route the I/O interface extension cable and the power cable (high-voltage/high-current cables) through different non-parallel routes.

4.2 Terminal Wiring

■ Input terminal circuit diagram

● Sink wiring

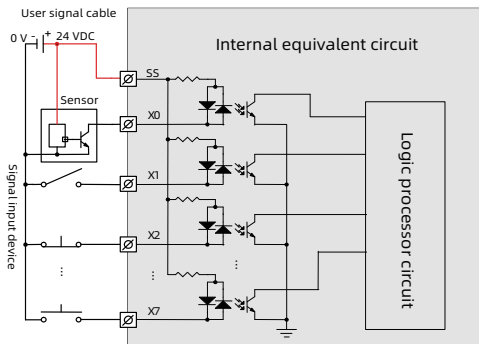

● Source wiring

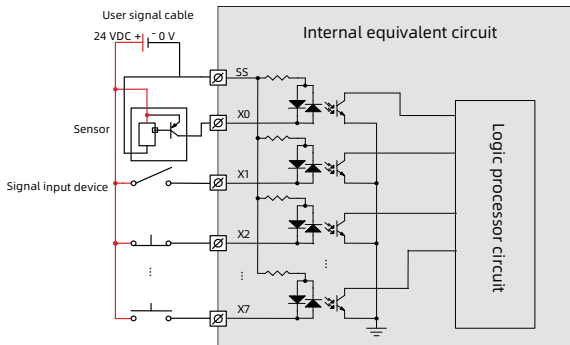

■ Output terminal circuit diagram

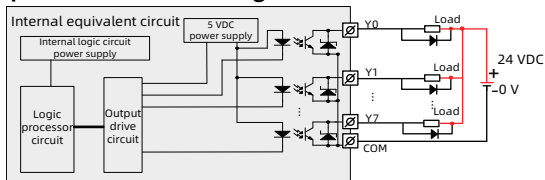

Note

An external flywheel diode is required when an inductive load is connected. In this case, use a 1N4001 or similar diode.

■ Input and output terminal wiring

- Easy52X-0808TN

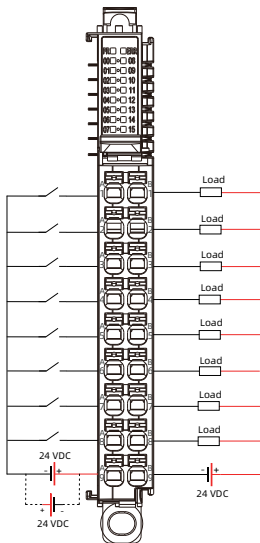

- Easy52X-0808TP

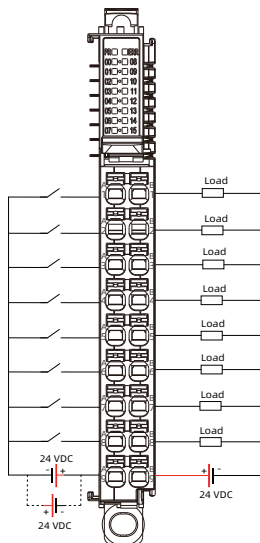

5 Communication Connection

5.1 Communication Networking

This PLC can be connected to other sites, ERP, MES and other systems through Ethernet interface, or connected to other slaves (such as MD520, MD800, SV630N and SV660N drives) or other modules with EtherCAT function through EtherCAT interface. With GE20 series extension cards, this PLC can also be connected to H5U, SV630C, and IR311 series industrial robots through RS485, RS232, or CAN communication, as shown below.

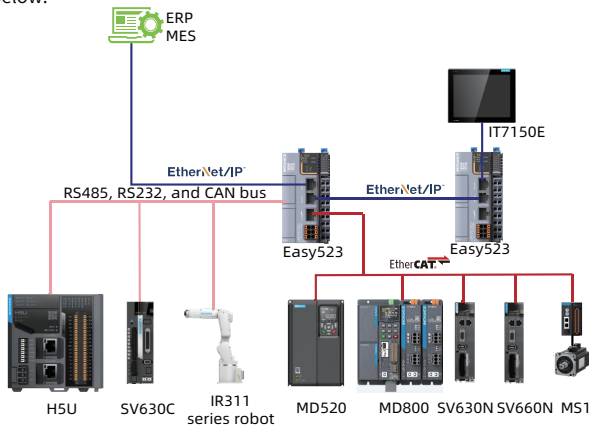

■ OPC UA topology

The MES system connects to the Easy320 and Easy52X PLCs through the OPC UA server, as shown in the following figure.

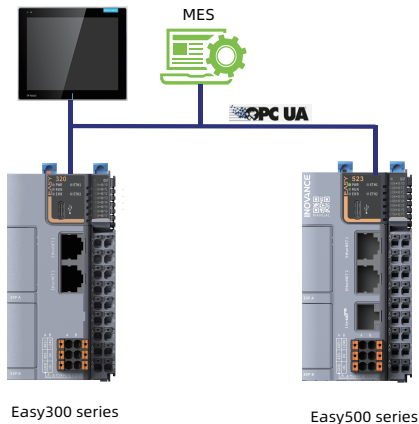

Easy300 series

Easy500 series

■ PROFINET topology

The PROFINET master connects to the Easy523 and Easy320 PLCs and the GL20 modules through PROFINET. It connects to other slaves, such as SV630N, SV660N, and other servos, as well as other EtherCAT-enabled modules through the EtherCAT port, as shown in the following figure.

PROFINET master

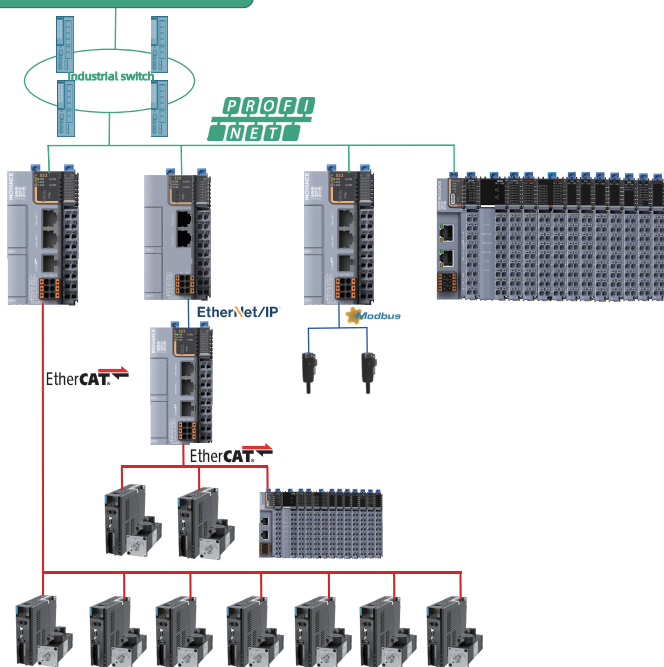

5.2 Cable Selection

The cable lugs and cable sizes in the following table are for reference only. Select proper cables based on actual situations.

Material Name	Applicable Cable Size	
	mm ²	AWG
Tubular lug	0.3	22
	0.5	20
	0.75	18
	1.0	18
	1.5	16

If other tubular lugs are used, crimp them to twisted cables. The following figure shows requirements on the shape and size.

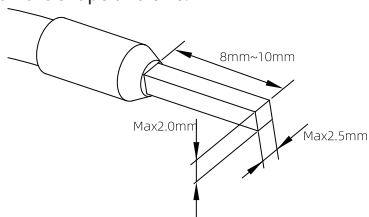

5.3 Cable Connection

■ RS485 communication

The RS485 communication port and the 24 V power supply port are located on the left and right of the same terminal block, respectively.

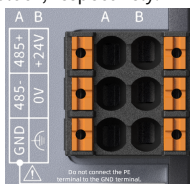

- Terminal definition

Signal	Left Terminal	Right Terminal	Signal
RS485 differential pair positive signal	485+	+24V	24 VDC power supply positive
RS485 differential pair negative signal	485-	0V	24 VDC power supply negative
RS485 communication ground	GND		PE



Caution

- Check the silk prints on both sides of the terminal to prevent wrong cable connection. Do not connect the GND cable to the I/O terminals on the lower side. Failure to comply can lead to short circuit and damage the components.
- Do not connect the PE cable to the GND terminal.

- Communication specifications

Item	Specification
Number of channels	3 (The PLC itself supports one channel and can support two more channels including RS232 through expansion cards.)
Hardware port	2 x 3-pin terminal (shared with the power supply)
Isolation mode	No isolation
Termination resistor	No (The PLC can be used as the master or slave.)
Number of slaves	31 (The cable length for each slave branch must be less than 3 m.)
Baud rate	9600 bps, 19,200 bps, 38,400 bps, 57,600 bps, or 115,200 bps
Transmission speed	<ul style="list-style-type: none"> • 10 Mbps: 10BASE-T • 100 Mbps: 100BASE-TX • 10 Mbps/100 Mbps self-adaptive
Short circuit protection	Protection against incorrect connection to the 24 V terminal

- Wiring

Select proper communication cables according to *"5.2 Cable Selection" on page 39* and insert the cables to the corresponding communication ports.

■ Ethernet communication

For reliable communication, use Cat 5 shielded twisted pair cables with injection molded, iron-shelled connectors as Ethernet cables.

- Insert the registered jack on the cable into the Ethernet port (RJ45 port) until a click is heard.
- To remove the RJ45 network cable, press and hold the tail of the registered jack, and then pull it out along the direction parallel with the PLC.

5.4 EtherCAT Communication

■ EtherCAT specifications

Item	Description
Communication protocol	EtherCAT protocol
Service supported	CoE (PDO and SDO)
Synchronization mode	Distributed clock (DC) for the servo and input/output synchronization for I/O
Physical layer	100BASE-TX
Baud rate	100 Mbps (100Base-TX)
Duplex mode	Full duplex
Topology	Linear topology
Transmission medium	Network cable (For details, see "Wiring".)
Transmission distance	Less than 100 m between two nodes
Number of slaves	Up to 72
EtherCAT frame length	44 bytes to 1498 bytes
Process data	Up to 1486 bytes per Ethernet frame

■ Wiring

The PLC provides a CN3 port for EtherCAT bus communication. The communication cable must meet the following requirements:

Communication network cable requirements

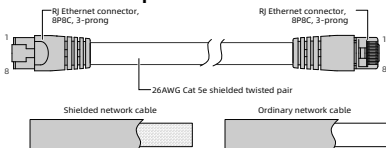

Signal pin assignment

Pin	Signal	Direction	Description
1	TD+	Output	Data transmission positive
2	TD-	Output	Data transmission negative
3	RD+	Input	Data receiving positive
4	-	-	Not used
5	-	-	Not used
6	RD-	Input	Data receiving negative
7	-	-	Not used
8	-	-	Not used

Cable requirements

100% continuity test without short circuit, open circuit, misalignment, or poor contact. Cables meeting the following requirements are recommended.

Item	Specification
Cable type	Flexible crossover cable, double-layer shielded (SFTP or SFTPP), Cat5e or above (100BASE-TX)
Double-layer shielded	Braided shield (coverage: 85%), aluminum foil shield (coverage: 100%)
Standard	EIA/TIA 568A, EN 50173, ISO/IEC 11801 EIA/TI Abulletin TSB, EIA/TIA SB40-A&TSB36

Item	Specification
Conductor size	AWG26 and above
Conductor type	Twisted pair
Number of pairs	4
Certification	UL
Environment	<ul style="list-style-type: none"> Resistant to industrial oil and acid and alkali corrosion Operating environment temperature: -30°C to +60°C



Caution

When using EtherCAT bus, the cable length between devices cannot exceed 100 m. Failure to comply can lead to signal attenuation, affecting the communication performance.

■ Recommended cables

The following table lists recommended network cables.

Cable Code	Cable Model	Cable Specification (m)
15040261	S6-T04-0.3	0.3
15040262	S6-T04-3.0	3.0
15041960	S6-T04-0.2	0.2
15041961	S6-T04-0.5	0.5
15041962	S6-T04-1.0	1.0
15041963	S6-T04-2.0	2.0
15041964	S6-T04-5.0	5.0
15041965	S6-T04-10.0	10.0

5.5 RS485 Communication

- It is recommended to use a shielded twisted pair cable to connect the 485+ and 485- ports of the RS485 bus.
- Connect a 120 Ω termination resistor at each end of the bus to prevent signal reflection.

- Connect the reference grounds of RS485 signals of all the nodes together.
- Up to 31 nodes can be connected to the RS485 bus and the cable length of any node branch must be less than 3 m.

The following figures show the RS485 bus topology.

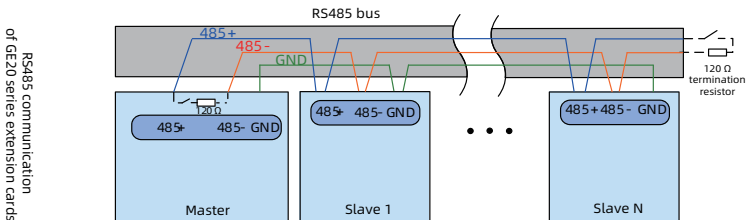
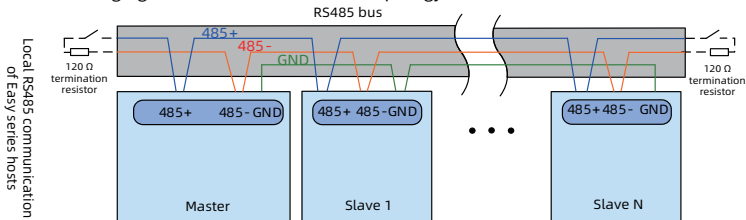

6 Operation and Maintenance

6.1 Program RUN and STOP

After writing a program to the STOP-status PLC, execute the following operations to run or stop the system:

State	Operation
To run the system	<ol style="list-style-type: none">1. Set the system to RUN status.2. Ensure the RUN indicator is solid on in yellow green.
To stop the system	Set the system to STOP status or stop the PLC through the host controller.

6.2 User Program Download with a TF Card

Prerequisite

- Prepare a TF card (Micro SD) with a capacity of 32 GB or less and a FAT32 file system.
- Power off the PLC.

Steps

1. Generate a Down/Updown file using AutoShop. For details, see "Applying the Function of Download File Generation" in the *H5U and Easy Series Programmable Logic Controllers Programming and Application Guide*.
2. Create a "PLCProgram" directory in the root directory of the TF card and copy the Down/Updown file to the "PLCProgram" directory.
3. Load the TF card into the TF expansion card and install the TF expansion card to the PLC.
4. Power on the PLC and download the user program in the TF card into the PLC. The RUN indicator flashes quickly at a frequency of 4 Hz during downloading.
5. After successful download, the RUN indicator flashes slowly at a frequency of 1 Hz and the PLC enters the STOP state. You can remove the TF card now.
If the ERR indicator flashes slowly, the download fails. Check whether the downloaded file is applicable to the PLC model and whether the login password of

the downloaded file is the same as that of the PLC. If the model and password are both correct but the download still fails, contact Inovance for technical support.

6. Re-power on the PLC.

6.3 Firmware Programming with a TF Card

Prerequisite

- Prepare a TF card (Micro SD) with a capacity of 32 GB or less and a FAT32 file system.
- Power off the PLC.

Note

Perform firmware programming carefully because the original application will be deleted and user data will be lost after firmware programming (in .img format).

Steps

1. Load the TF card into the TF expansion card and mount the TF expansion card to the PLC.
2. Power on the PLC again.

The state of firmware programming is indicated by the RUN and ERR indicators: Flashing quickly for three seconds indicates the start of firmware programming. Remaining solid on indicates firmware programming is in progress. Flashing slowly indicates firmware programming is completed.

3. After firmware programming is completed, power off the PLC and remove the TF card.
4. Power on the PLC again.

6.4 Address Conflict Detection

■ Introduction

The address conflict detection function is used to check whether the IP address of the network adapter of a device is occupied by other devices in the current network after this device is connected to the network, its IP address is modified, or the Ethernet port cable is removed. If the IP address has been occupied, check the alarm information through troubleshooting or by referring to the system operation log page.



Address conflict detection is the default system behavior.

■ Viewing alarms

Prerequisites

- Firmware version: V6.4.0.0 and later
- Software version: AutoShop V4.10.2.0 and later
- Easy523 is connected.

Procedure

1. In the menu bar, choose "Tools(T)" > "Communication Settings". On the page displayed, modify the IP addresses of two Easy523 PLCs to 192.168.1.88. Then, only one device with the IP address 192.168.1.88 can be detected in the Ethernet, as shown in the following figure.

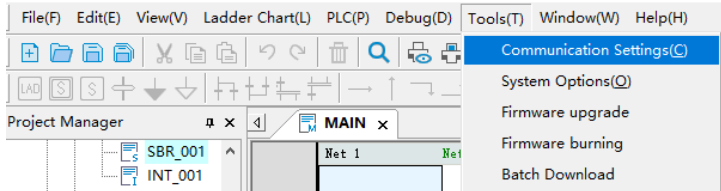

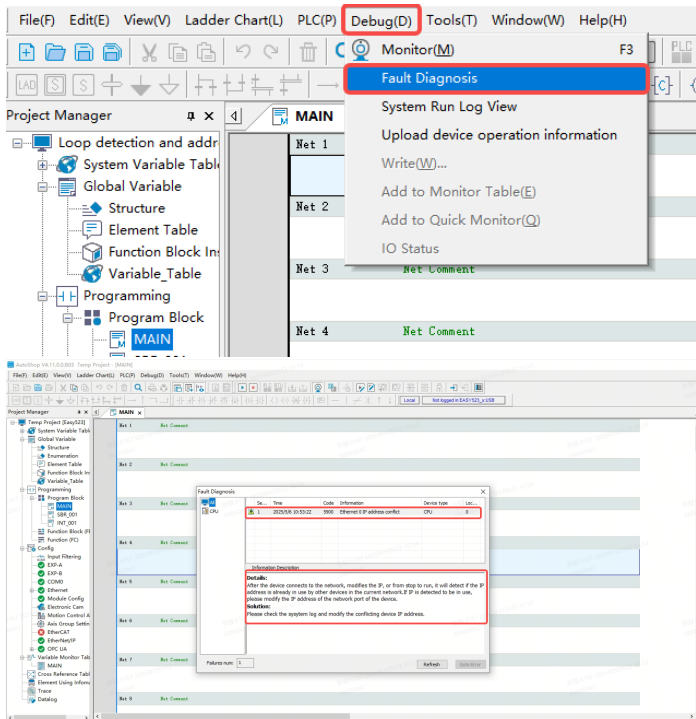

- In the software, choose "Debug(D)" > "System Run Log View" in the menu bar at the top to view the diagnosis information of "Ethernet IP address conflict". Conflicting IP address, network adapter name, and MAC address are displayed in the logs, as shown in the following figure.

The screenshot shows the Siemens SIMATIC Manager interface. The 'Debug(D)' menu is open, and the 'System Run Log View' option is selected. The main window displays a ladder logic diagram with five networks, each labeled 'Net X' and 'Net Comment'. A 'System Run Log' window is open in the foreground, showing a table of system events. The last entry in the log is highlighted in red:

Time	Date	Event	Comment
10:11:30.000	2008/07/17 20:14:42	updated ip: 192.168.1.101 successful when: 4182 sec: 10.53s.427	

3. Correct the conflicting IP address. Then, the diagnosis information of "Ethernet IP address conflict" disappears from the "Fault Diagnosis" window and the "System Run Log" window, a shown in the following figure.

Fault Diagnosis

Se...	Time	Code	Information	Device type	Loc...
Information Description					

Failures num:

System Run Log

Warning(13)
 Error(2)
 Exception(0)
 Debug(0)
 Info(3156)
 Elements: All

Display Time Stamps in PC local Time

NO.	Level	Time	Description	Element
3002	Info	2025/5/6 10:52:06	Hook stop 3/3: EthIPScanner: clear error done	EtherNet/IP Scanner
3003	Info	2025/5/6 10:52:06	Hook 2/2: EthIPScanner: End hook event 0.	EtherNet/IP Scanner
3004	Info	2025/5/6 10:52:06	Hook 1/2: EthIPAdapter: Start hook event 0.	EtherNet/IP Scanner
3005	Info	2025/5/6 10:52:06	Hook stop 1/5: EthIPAdapter: ONF_EVT_STOP	EtherNet/IP Scanner
3006	Info	2025/5/6 10:52:06	Hook stop 2/5: EthIPAdapter: cancel thread done	EtherNet/IP Scanner
3007	Info	2025/5/6 10:52:06	EipStackDlt 1/3: EthIPScanner: Start delete stack	EtherNet/IP Scanner
3008	Info	2025/5/6 10:52:06	EtherCAT: allowlock_run_cmd_1=0	EtherCAT
3009	Info	2025/5/6 10:52:06	EVT_STATE_RUN_2_IDLE 0	EtherCAT
3010	Info	2025/5/6 10:52:06	EtherCAT: Stop master	EtherCAT
3011	Info	2025/5/6 10:52:06	EtherCAT: Stop master finished.	EtherCAT
3012	Info	2025/5/6 10:52:06	ThreadRun 3/3: EthIPScanner: End diag thread	EtherNet/IP Scanner
3013	Info	2025/5/6 10:52:06	EipStackDlt 2/3: EthIPScanner: diag task stop	EtherNet/IP Scanner
3014	Info	2025/5/6 10:52:06	ThreadRun 2/2: EthIPScanner: end eventDeal thread	EtherNet/IP Scanner
3015	Info	2025/5/6 10:52:06	ThreadRun 2/2: EthIPScanner: End running stack	EtherNet/IP Scanner
3016	Info	2025/5/6 10:52:06	EipStackDlt 2/3: EthIPScanner: EthIPScannerStop done	EtherNet/IP Scanner
3017	Info	2025/5/6 10:52:06	EipStackDlt 2/3: EthIPScanner: eventcallback_Thread task stop	EtherNet/IP Scanner
3018	Info	2025/5/6 10:52:06	EipStackDlt 3/3: EthIPScanner: End delete stack	EtherNet/IP Scanner
3019	Info	2025/5/6 10:52:06	Hook stop 3/5: EthIPAdapter: delete stack done	EtherNet/IP Scanner
3020	Info	2025/5/6 10:52:06	Hook stop 4/5: EthIPAdapter: clear adapter error done	EtherNet/IP Scanner
3021	Info	2025/5/6 10:52:06	Hook stop 5/5: EthIPAdapter: clear scanner error done	EtherNet/IP Scanner
3022	Info	2025/5/6 10:52:06	Hook 2/2: EthIPAdapter: End hook event 0.	EtherNet/IP Scanner
3023	Info	2025/5/6 10:52:06	[monitor]login event:0 route:10	CPU
3024	Info	2025/5/6 10:52:06	[monitor]login event:1 route:10	CPU
3025	Info	2025/5/6 10:52:06	[monitor]login event:2 route:10	CPU
3026	Info	2025/5/6 10:52:06	Eth0_192.168.1.89 Mask_255.255.255.0 Gateway_192.168.1.1	CPU
3027	Info	2025/5/6 10:52:55	run status changed to RUN!!! because of control word.	CPU
3028	Info	2025/5/6 10:52:55	EtherCAT: Start to get config data.	EtherCAT
3029	Info	2025/5/6 10:52:55	EtherCAT: Cycle time is 4000 us.	EtherCAT
3030	Info	2025/5/6 10:52:55	EtherCAT: There are 0 slave(s) configured	EtherCAT

6.5 Loop Detection

■ Introduction

When loop detection is enabled, after a device is connected to the network, the system checks whether the device is in a loop in the current network. When a loop is detected, you can view and print the diagnosis and log information in the "System Diagnosis" and "System Run Log" windows, which shows that a network loop exists and the loop connection must be disconnected.

■ Function configuration

Prerequisites

- Firmware version: V6.4.0.0 and later
- Software version: AutoShop V4.10.2.0 and later
- Easy523 is connected.

Procedure

1. In the menu bar, choose "PLC(P)" > "Loop detection". The "Loop detection" configuration page is displayed, as shown in the following figure.

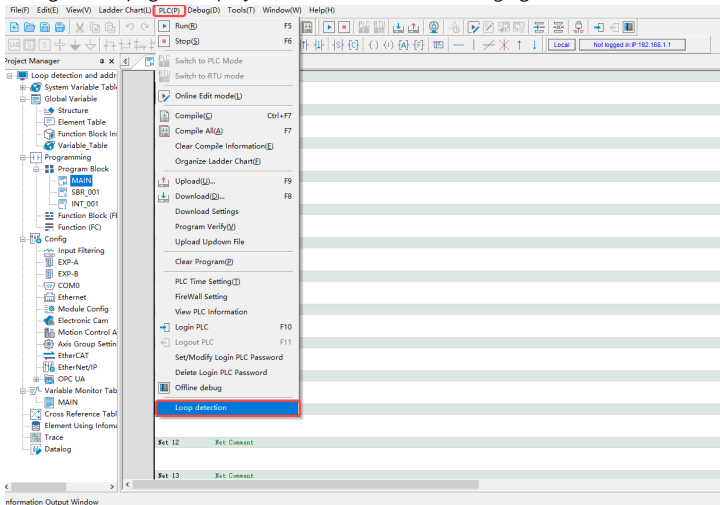

2. On this page, "Current monitoring cycle" and "Current monitoring status" (Start/ Stop) are automatically identified and displayed. You can set "Monitoring cycle" to 500 ms at ①, and click "Start" at ② to enable loop detection, as shown in the following figure.

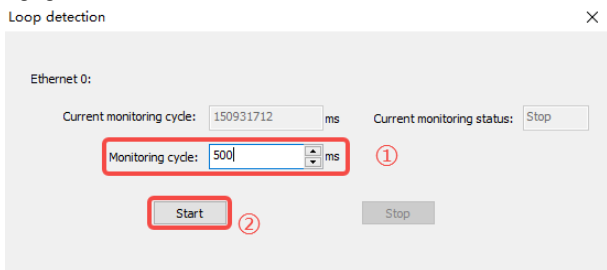

3. The "Loop monitoring enabled command executed correctly" message is displayed in the "Information Output Window" area. In the "Loop detection" window, the current monitoring cycle is updated to the set cycle and the current monitoring status changes to "Start", as shown in the following figure.

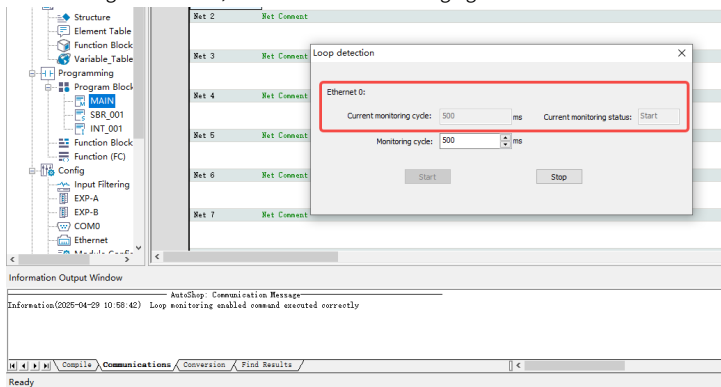

To disable the loop detection function, click "Stop" in the "Loop detection" window. Then, the prompt "Loop monitoring closed command executed correctly" is displayed in the "Information Output Window" area and the current monitoring

status in the "Loop detection" window changes to "Stop", as shown in the following figure.

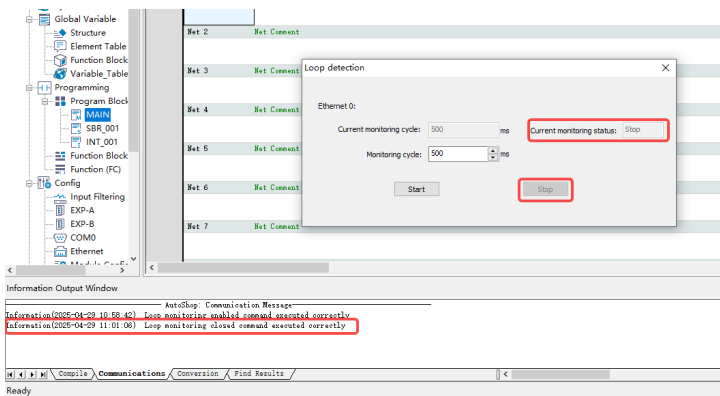

■ Viewing alarms

Prerequisites

- Autoshop is started.
- Easy523 is connected.

Procedure

1. You can view the loop alarm in any of the following two ways.

- In the menu bar, choose "Debug(D)" > "Fault Diagnosis" to view the loop alarm information, as shown in the following figure.

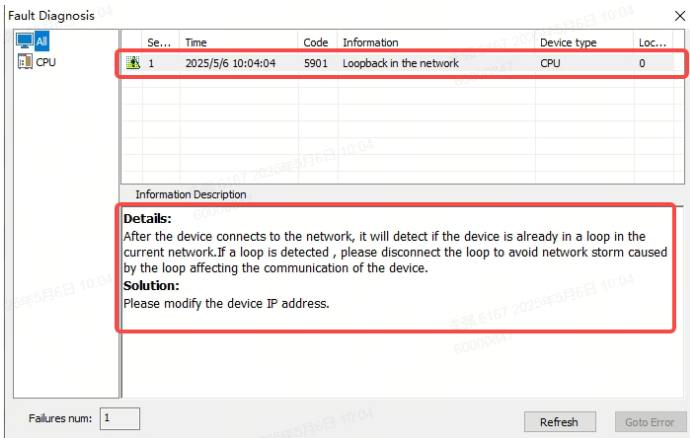

Click a diagnosis information item to view the details and solutions of a loop detection alarm, as shown in the following figure.

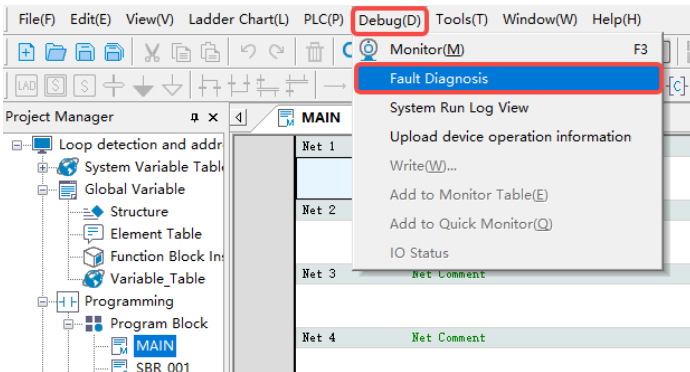

- In the menu bar, choose "Debug(D)" > "System Run Log View" to view the loop alarm information. When the system network has a loop, the alarm log indicating that Ethernet0 has a loop is displayed, as shown in the following figure.

The screenshot shows the SIMATIC Manager interface. The 'Debug(D)' menu is open, and 'System Run Log View' is selected. Below, the 'System Run Log' window displays a list of events. The entry at the bottom, 'interface name: eth0 loop detected', is highlighted with a red box.

NO.	Level	Time	Description	Element
2879	Info	2025/5/6 09:26:54	Update 10/10: EthIPAdapter: update protocol_flag done	EtherNet/IP Scanner
2880	Info	2025/5/6 09:26:54	Update 11/10: EthIPAdapter: End updating.	EtherNet/IP Scanner
2881	Info	2025/5/6 09:26:54	[FirstRun] Mem-Variables load begin.	CPU
2882	Info	2025/5/6 09:26:54	[FirstRun] Mem-Variables load finished.	CPU
2883	Info	2025/5/6 09:26:54	EtherCAT: Received run command.	EtherCAT
2884	Info	2025/5/6 09:26:54	Hook 1/2: EthIPScanner: Start hook event 1.	EtherNet/IP Scanner
2885	Info	2025/5/6 09:26:54	Hook run 1/4: EthIPScanner: CMP_EVT_RUN	EtherNet/IP Scanner
2886	Info	2025/5/6 09:26:54	Update 1/2: EthIPScanner: update cipudlist done	EtherNet/IP Scanner
2887	Info	2025/5/6 09:26:54	Update 2/2: EthIPScanner: update cipexplicittag done	EtherNet/IP Scanner
2888	Info	2025/5/6 09:26:54	Hook run 2/4: EthIPScanner: update cip config ret 0	EtherNet/IP Scanner
2889	Info	2025/5/6 09:26:54	EipStackCt 1/2: EthIPScanner: Start create stack	EtherNet/IP Scanner
2890	Info	2025/5/6 09:26:54	ThreadRun 1/2: EthIPScanner: Start eventDeal thread	EtherNet/IP Scanner
2891	Info	2025/5/6 09:26:54	ThreadRun 1/2: EthIPScanner: Start running stack	EtherNet/IP Scanner
2892	Info	2025/5/6 09:26:54	ThreadRun 1/3: EthIPScanner: Start diag thread	EtherNet/IP Scanner
2893	Info	2025/5/6 09:26:54	ThreadRun 2/3: EthIPScanner: diag thread cycle	EtherNet/IP Scanner
2894	Info	2025/5/6 09:26:54	EipStackCt 2/2: EthIPScanner: End create stack	EtherNet/IP Scanner
2895	Info	2025/5/6 09:26:54	Hook run 3/4: EthIPScanner: create stack done	EtherNet/IP Scanner
2896	Info	2025/5/6 09:26:54	Hook run 4/4: EthIPScanner: create thread done	EtherNet/IP Scanner
2897	Info	2025/5/6 09:26:54	Hook 2/2: EthIPScanner: End hook event 1.	EtherNet/IP Scanner
2898	Info	2025/5/6 09:26:54	Hook 1/2: EthIPAdapter: Start hook event 1.	EtherNet/IP Scanner
2899	Info	2025/5/6 09:26:54	Hook 2/2: EthIPAdapter: End hook event 1.	EtherNet/IP Scanner
2900	Info	2025/5/6 09:26:54	Hook 1/2: EthIPScanner: Start hook event 4.	EtherNet/IP Scanner
2901	Info	2025/5/6 09:26:54	Hook 2/2: EthIPScanner: End hook event 4.	EtherNet/IP Scanner
2902	Info	2025/5/6 09:26:54	Hook 1/2: EthIPAdapter: Start hook event 4.	EtherNet/IP Scanner
2903	Info	2025/5/6 09:26:54	Hook 2/2: EthIPAdapter: End hook event 4.	EtherNet/IP Scanner
2904	Info	2025/5/6 09:26:54	EtherCAT: Start to register master.	EtherCAT
2905	Info	2025/5/6 09:26:55	EtherCAT: Master Active.	EtherCAT
2906	Warning	2025/5/6 10:04:04	Warning 5901 at 0(0x0).	CPU
2907	Error	2025/5/6 10:04:04	interface name: eth0 loop detected	CPU

2. Disconnect the network with the loop.

The network loop diagnosis information disappears and "eth0 loop elimination" is displayed in the system operation log, as shown in the following figure.

Fault Diagnosis

Se...	Time	Code	Information	Device type	Loc...
Information Description					

Failures num:

System Run Log

Warning(11)
 Error(1)
 Exception(0)
 Debug(0)
 Info(2895)
 Elements: All

Display Time Stamps in PC local Time

NO.	Level	Time	Description	Element
2879	Info	2025/5/6 09:26:54	Update 10/10: EthIPAdapter: update protocol_flag done	EtherNet/IP Scanner
2880	Info	2025/5/6 09:26:54	Update 11/10: EthIPAdapter: End updating.	EtherNet/IP Scanner
2881	Info	2025/5/6 09:26:54	[FirstRun] Mem-Variables load begin	CPU
2882	Info	2025/5/6 09:26:54	[FirstRun] Mem-Variables load finished.	CPU
2883	Info	2025/5/6 09:26:54	EtherCAT: Received run command.	EtherCAT
2884	Info	2025/5/6 09:26:54	Hook 1/2: EthIPScanner: Start hook event 1.	EtherNet/IP Scanner
2885	Info	2025/5/6 09:26:54	Hook run 1/4: EthIPScanner: CMP_EVT_RUN	EtherNet/IP Scanner
2886	Info	2025/5/6 09:26:54	Update 1/2: EthIPScanner: update cipudlist done	EtherNet/IP Scanner
2887	Info	2025/5/6 09:26:54	Update 2/2: EthIPScanner: update cipexplicittag done	EtherNet/IP Scanner
2888	Info	2025/5/6 09:26:54	Hook run 2/4: EthIPScanner: update oip config ret 0	EtherNet/IP Scanner
2889	Info	2025/5/6 09:26:54	EipStackCt 1/2: EthIPScanner: Start create stack	EtherNet/IP Scanner
2890	Info	2025/5/6 09:26:54	ThreadRun 1/2: EthIPScanner: Start eventDeal thread	EtherNet/IP Scanner
2891	Info	2025/5/6 09:26:54	ThreadRun 1/2: EthIPScanner: Start running stack	EtherNet/IP Scanner
2892	Info	2025/5/6 09:26:54	ThreadRun 1/3: EthIPScanner: Start diag thread	EtherNet/IP Scanner
2893	Info	2025/5/6 09:26:54	ThreadRun 2/3: EthIPScanner: Start diag thread cycle	EtherNet/IP Scanner
2894	Info	2025/5/6 09:26:54	EipStackCt 2/2: EthIPScanner: End create stack	EtherNet/IP Scanner
2895	Info	2025/5/6 09:26:54	Hook run 3/4: EthIPScanner: create stack done	EtherNet/IP Scanner
2896	Info	2025/5/6 09:26:54	Hook run 4/4: EthIPScanner: create thread done	EtherNet/IP Scanner
2897	Info	2025/5/6 09:26:54	Hook 2/2: EthIPScanner: End hook event 1.	EtherNet/IP Scanner
2898	Info	2025/5/6 09:26:54	Hook 1/2: EthIPAdapter: Start hook event 1.	EtherNet/IP Scanner
2899	Info	2025/5/6 09:26:54	Hook 2/2: EthIPAdapter: End hook event 1.	EtherNet/IP Scanner
2900	Info	2025/5/6 09:26:54	Hook 1/2: EthIPScanner: Start hook event 4.	EtherNet/IP Scanner
2901	Info	2025/5/6 09:26:54	Hook 2/2: EthIPScanner: End hook event 4.	EtherNet/IP Scanner
2902	Info	2025/5/6 09:26:54	Hook 1/2: EthIPAdapter: Start hook event 4.	EtherNet/IP Scanner
2903	Info	2025/5/6 09:26:54	Hook 2/2: EthIPAdapter: End hook event 4.	EtherNet/IP Scanner
2904	Info	2025/5/6 09:26:54	EtherCAT: Start to register master.	EtherCAT
2905	Info	2025/5/6 09:26:55	EtherCAT: Master Active	EtherCAT
2906	Warning	2025/5/6 10:04:04	Warning 5901 eliminated at 0(0x0).	CPU
2907	Error	2025/5/6 10:04:04	interface name: eth0 loop elimination	CPU

7 Appendix

■ Easy52X programmable controllers

Model	Description	Code
Easy521-0808TN-INT	Easy500 series 8-input 8-output 8-axis programmable controller	01441173
Easy522-0808TN-INT	Easy500 series 8-input 8-output 16-axis programmable controller	01441188
Easy523-0808TN-INT	Easy500 series 8-input 8-output 32-axis programmable controller	01441208
Easy521-0808TP-INT	Easy500 series 8-input 8-output 8-axis programmable controller	01441160
Easy522-0808TP-INT	Easy500 series 8-input 8-output 16-axis programmable controller	01441210
Easy523-0808TP-INT	Easy500 series 8-input 8-output 32-axis programmable controller	01441206

■ GE20 expansion cards

Type	Model	Description	Code	Slot	ID
Digital input/output	GE20-4DI-INT	4-channel input 24 VDC input Source/Sink	01480130	A/B	13
	GE20-4DO-TN-INT	4-channel sink transistor output 24 VDC output	01480115	A/B	5
Analog input/output	GE20-2AD1DA-I-INT	2-channel analog input and 1-channel analog output (current type)	01480138	A/B	11
	GE20-2AD1DA-V-INT	2-channel analog input and 1-channel analog output (voltage type)	01480107	A/B	3

Type	Model	Description	Code	Slot	ID
Communication	GE20-CAN-485-INT	CAN and RS485 communication (RJ45)	01480114	A	15
	GE20-232/485-INT	RS232 or RS485 communication	01480119	A/B	7
	GE20-232/485-RTC-INT	RS232 or RS485 communication (with RTC)	01480122	B	14
Storage	GE20-TF-INT	TF expansion card	01480109	B	1
	GE20-TF-RTC-INT	Memory expansion card (with integrated RTC)	01480132	B	6
Clock	GE20-RTC-INT	Clock expansion card	01480099	B	9

Note

The ID is "0" when there is no expansion card. For expansion card IDs, see the relevant expansion card user guides.

■ GL20 extension module

Module	Model	Description	Code
Digital	GL20-0016ETP-INT	16-channel digital output (PNP)	01441069
	GL20-1600END-INT	16-channel digital input	01441085
	GL20-0016ETN-INT	16-channel digital output (NPN)	01441063
	GL20-0800END-INT	8-channel digital input	01441054
	GL20-0008ETP-INT	8-channel digital output (PNP)	01441062
	GL20-0008ETN-INT	8-channel digital output (NPN)	01441058
	GL20-0808ETN-INT	8-channel digital input and 8-channel digital output (NPN)	01441072
	GL20-0008ER-INT	8-channel relay output module	01441064
	GL20-3200END-INT	32-channel digital input	01441067
	GL20-0032ETN-INT	32-channel digital output (NPN)	01441079
	GL20-0404ETP-5V-INT	5 VDC, 4-channel digital input and 4-channel digital output (about to release)	01441070
	GL20-3232ETN-M-INT	32-channel digital input and 32-channel digital output (NPN), with external terminal block wiring	01441080
Analog	GL20-4AD-INT	4-channel analog input	01441075
	GL20-4DA-INT	4-channel analog output	01441089
	GL20-8ADV-INT	8-channel analog input	01441086
	GL20-8ADI-INT	8-channel analog input	01441092
Temperature measurement	GL20-4PT-INT	4-channel thermistor input type	01441074
	GL20-4TC-INT	4-channel thermocouple input type	01441066

Module	Model	Description	Code
Commu- nication	GL20-2SCOM-INT	2-channel serial module (third-party products not supported)	01441084
	GL20-2S485-INT	2-channel RS485 expansion module, currently only supporting EtherCAT couplers (third-party products not supported)	01441071
Process module	GL20-2SSI-INT	2-channel SSI communication	01441056

Service and Support

Should you encounter a safety accident during the use or operation of the product, or face challenges in operating and maintaining the equipment, which remain unresolved after the relevant documentation is consulted, we provide multiple channels to ensure prompt resolution:

- Channel #1: Contact service@inovance.com.
- Channel #2: Visit <https://www.inovance.com/global> to access document downloads, after-sales support, spare parts ordering, repair applications, and authenticity verification services.
- Channel #3: Download My Inovance app (<https://zshc-eu.inovance.com/download-pc/>) where you can access products info and documentation, and query product parameters.

We are committed to providing you with quick and professional technical support, and we look forward to your satisfaction and trust.

Importa y distribuye en Argentina:

ECFA

ECFA S.R.L.

 Av. San Juan 4063 (C1233ABK) - Buenos Aires - Argentina

 +54 11 4923-6566

 ventas@ecfa.com.ar

 <https://www.ecfa.com.ar>