

INOVANCE

FORWARD, ALWAYS PROGRESSING

Importa y distribuye en Argentina:

ECFA



MD520 Series General-Purpose AC Drive Quick Installation and Commissioning Guide



Industrial
Automation



Intelligent
Elevator



New Energy
Vehicle



Industrial
Robot



Rail
Transit



Data code 19011712B01

Preface

Introduction

The MD520 series is a general-purpose high-performance vector control AC drive for accurate speed and torque control in high-demand applications. It can drive asynchronous AC induction motors (IM), permanent magnet synchronous motors (PMSM), and synchronous reluctance motors (SynRM). It is also equipped with the STO, limp mode upon fault, position control, and tension control functions.

This guide describes the installation, wiring, commissioning, and troubleshooting of the AC drive. For complete information on parameters and fault codes, see *MD520 Series General-Purpose AC Drive Parameter Guide*.

More Data

Document Name	Data Code	Description
MD520 Series General-Purpose AC Drive User Guide	PS00012134	This guide describes product selection, mechanical design, electrical design, installation, communication, commissioning, function application, troubleshooting, and standards.
MD520 Series General-Purpose AC Drive Parameter Guide	19012397	This guide describes parameters and fault codes.
MD520 Series General-Purpose AC Drive Quick Installation and Commissioning Guide (this guide)	19011712	This guide describes the installation, wiring, commissioning, troubleshooting, and others.
MD520 Series General-Purpose AC Drive Hardware Guide	19011713	This guide describes the system composition, technical specifications, components, dimensions, options (including installation accessories, cables, and peripheral electrical components), expansion cards, routine inspection and maintenance, certifications, and standards of the AC drive.
MD520 Series General-Purpose AC Drive Installation Guide	19011714	This guide describes the installation dimensions, space design, specific installation steps, wiring requirements, routing requirements, option installation requirements, and common EMC troubleshooting suggestions.
MD520 Series General-Purpose AC Drive Commissioning Guide	19011715	This guide describes commissioning tools, commissioning flowchart, detailed commissioning steps, and troubleshooting.

Document Name	Data Code	Description
MD520 Series General-Purpose AC Drive Communication Guide	19011716	This guide describes the communication mode, communication networking, and communication configuration of the product.
MD520 Series General-Purpose AC Drive Function Guide	19011717	This guide describes function applications, and troubleshooting of the product.
MD520 Series General-Purpose AC Drive Safety Function Guide	19011795	This guide describes the safety information, instructions for mechanical and electrical installation, commissioning and maintenance guidance, and safety-related parameters of the AC drive.

Revision History

Date	Docu-ment Version	Software Version	Revision
September 2024	B01	Version: A13 Version tag: F7-10=U60.07/F7-11=U61.11/F7-15=000.00/F7-16=000.00	Modified the following content: <ul style="list-style-type: none"> • Made minor corrections.
August 2024	B00	Version: A13 Version tag: F7-10=U60.07/F7-11=U61.11/F7-15=000.00/F7-16=000.00	Modified the following content: <ul style="list-style-type: none"> • Updated "3.2 Basic Commissioning Flowchart" on page 58. • Updated "3.3 Commissioning Flowchart in V/f Control Mode" on page 60. • Updated "3.4 Commissioning Flowchart in SVC Mode" on page 62. • Updated "3.5 Commissioning Flowchart in FVC Mode" on page 64. • Made minor corrections. • Deleted the PMVC function.
February 2024	A02	Version: A12 Version tag: F7-10=U60.07/F7-11=U61.10/F7-15=000.00/F7-16=000.00	Deleted the following content: <ul style="list-style-type: none"> • Deleted 4.2 List of Fault Codes and 4.3 List of Fault Attributes. Added "4.2 List of Faults and Alarms" on page 74. For details on fault codes, see the parameter guide. • Deleted 5 Parameter List. <p>For complete information on parameters and fault codes, see <i>MD520 Series General-Purpose AC Drive Parameter Guide</i>.</p>

Date	Docu ment Version	Software Version	Revision
November 2023	A01	Version: A10 Version tag: F7-10= U60.07/F7-11= U61.08/F7-15= 000.00/F7-16=000.00	<p>Modified the following content:</p> <ul style="list-style-type: none"> • Updated the fault information in section 4.2 Fault List. • Updated Parameter List. • Made minor corrections. <p>Added the following content:</p> <ul style="list-style-type: none"> • Added <i>"1.2.4.1 Removing the Cover" on page 29.</i> • Added <i>"1.2.4.2 Installing the Cover" on page 30.</i> • Added <i>"Installing T13 Models" on page 32.</i>
January 2022	A00	–	First issue

Access to the Guide

This guide is not delivered with the product. You can obtain the PDF version by the following methods:

- Do keyword search under **Service and Support** at <http://www.inovance.com>.
- Scan the QR code on the product with your smart phone.
- Scan the QR code below to install the app, where you can search for and download manuals.



Warranty Disclaimer

Inovance provides warranty service within the warranty period (as specified in your order) for any fault or damage that is caused by proper operation of the user. Maintenance will be charged after the warranty expires.

Within the warranty period, maintenance fee will be charged for the following damage:

- Damage caused by operations not following the instructions in the user guide
- Damage caused by fire, flood, or unusual voltage
- Damage caused by unintended use of the product
- Damage caused by use beyond the specified scope of application of the product
- Damage or secondary damage caused by force majeure (natural disaster, earthquake, and lightning strike)

The maintenance is charged according to the latest Price List of Inovance. If otherwise agreed upon, the terms and conditions in the agreement shall prevail.

For details, see Product Warranty Card.

Table of Contents

Preface	1
Fundamental Safety Instructions	7
Product Model List	13
1 Mechanical Installation.....	15
1.1 T1 to T9 Model Installation	15
1.1.1 Dimensions of T1 to T9 Models	15
1.1.2 Backplate Mounting	17
1.1.3 Through-Hole Mounting	19
1.2 T10 to T12 Model Installation	22
1.2.1 Dimensions of T10 to T12 Models (Without AC Output Reactor)	22
1.2.2 Dimensions of T10 to T12 Models (with AC Output Reactor)	23
1.2.3 Installation Within the Cabinet	24
1.2.4 Cover Removal and Installation	29
1.2.4.1 Removing the Cover	29
1.2.4.2 Installing the Cover	30
1.3 T13 Model Installation	32
1.3.1 Dimensions of T13 Models (Without Auxiliary Power Distribution Cabinet)	32
1.3.2 Dimensions of T13 Models (with Auxiliary Power Distribution Cabinet)	34
1.3.3 Requirements on Ground Levelness	35
1.3.4 Expansion Screw Installation	36
1.3.5 Requirements on foundation	36
1.3.6 External Braking Unit Installation	37
2 Electrical Installation.....	40
2.1 Electrical Connection	40
2.2 Descriptions of Main Circuit Terminals.....	42
2.3 Descriptions of Control Circuit Terminals	46
3 Commissioning Flowchart	51
3.1 LED Operating Panel	51
3.2 Basic Commissioning Flowchart	58
3.3 Commissioning Flowchart in V/f Control Mode	60
3.4 Commissioning Flowchart in SVC Mode.....	62
3.5 Commissioning Flowchart in FVC Mode.....	64
4 Troubleshooting.....	66
4.1 Common Faults and Diagnosis.....	66
4.1.1 Alarm and Fault Display	66
4.1.2 Restart After Fault Occurrence	66

4.1.3 Common Troubleshooting.	69
4.1.4 Troubleshooting During Trial Run in Different Control Modes	72
4.2 List of Faults and Alarms	74

Fundamental Safety Instructions

Safety Precautions

- This chapter presents essential safety instructions for a proper use of the equipment. Before using this product, read the user guide thoroughly and correctly understand the related safety precautions. Failure to observe the safety precautions may result in serious injuries or death of personnel or device damage.
- "Danger", "Warning", and "Caution" items in this guide do not indicate all safety precautions that need to be followed; instead, they just supplement the safety precautions.
- Use this equipment according to the designated environment requirements. Damage caused by improper use is not covered by warranty.
- Inovance shall take no responsibility for any personal injuries or property damage caused by improper usage.

Safety Levels and Definitions



Indicates that failure to comply with the notice will result in death or severe personal injuries.



Indicates that failure to comply with the notice may result in death or severe personal injury.



Indicates that failure to comply with the notice may result in minor or moderate personal injury or equipment damage.

General Safety Instructions

- Drawings in the guide are sometimes shown without covers or protective guards. Remember to install the covers or protective guards as specified first, and then perform operations in accordance with the instructions.
- The drawings in the guide are shown for illustration only and may be different from the product you purchased.
- Operators must take mechanical precautions to protect personal safety and wear protective equipment, such as anti-smashing shoes, safety clothing, safety glasses, protective gloves, and protective sleeves.

Unpacking

WARNING

- Do not install the equipment if you find damage, rust, or signs of use on the equipment or accessories upon unpacking.
- Do not install the equipment if you find water seepage or missing or damaged components upon unpacking.
- Do not install the equipment if you find the packing list does not conform to the equipment you received.

CAUTION

- Check whether the packing is intact and whether there is damage, water seepage, dampness, and deformation before unpacking.
- Unpack the package by following the unpacking sequence. Do not strike the package violently.
- Check whether there is damage, rust, or injuries on the surface of the equipment and equipment accessories before unpacking.
- Check whether the package contents are consistent with the packing list before unpacking.

Storage and Transportation

WARNING

- Large-scale or heavy equipment must be transported by qualified professionals using specialized hoisting equipment. Failure to comply may result in personal injuries or equipment damage.
- Before hoisting the equipment, ensure the components such as the front cover and terminal blocks are secured firmly with screws. Loosely-connected components may fall off and result in personal injury or equipment damage.
- Never stand or stay below the equipment when the equipment is being hoisted by the hoisting equipment.
- When hoisting the equipment with a steel rope, ensure the equipment is hoisted at a constant speed without suffering from vibration or shock. Do not turn the equipment over or let the equipment stay hanging in the air. Failure to comply may result in personal injuries or equipment damage.

 CAUTION

- Handle the equipment with care during transportation and mind your steps to prevent personal injuries or equipment damage.
- When carrying the equipment with bare hands, hold the equipment casing firmly with care to prevent parts from falling. Failure to comply may result in personal injuries.
- Store and transport the equipment based on the storage and transportation requirements. Failure to comply will result in equipment damage.
- Avoid storing or transporting the equipment in environments with water splash, rain, direct sunlight, strong electric field, strong magnetic field, and strong vibration.
- Avoid storing the product for more than three months. Long-term storage requires stricter protection and necessary inspections.
- Pack the equipment strictly before transportation. Use a sealed box for long-distance transportation.
- Never transport the drive with other equipment or materials that may harm or have negative impacts on the drive.

Installation DANGER

- The equipment must be operated only by professionals with electrical knowledge.

 WARNING

- Read through the guide and safety instructions before installation.
- Do not install this equipment in places with strong electric or magnetic fields.
- Before installation, check that the mechanical strength of the installation site can bear the weight of the equipment. Failure to comply will result in mechanical hazards.
- Do not wear loose clothes or accessories during installation. Failure to comply may result in an electric shock.
- When installing the equipment in a closed environment (such as a cabinet or casing), use a cooling device (such as a fan or air conditioner) to cool the environment down to the required temperature. Failure to comply may result in equipment over-temperature or a fire.
- Do not retrofit the equipment.
- Do not fiddle with the bolts used to fix equipment components or the bolts marked in red.
- When the equipment is installed in a cabinet or final assembly, a fireproof enclosure providing both electrical and mechanical protections must be provided. The IP rating must meet IEC standards and local laws and regulations.
- Before installing devices with strong electromagnetic interference, such as a transformer, install a shielding device for the equipment to prevent malfunction.
- Install the product on an incombustible object such as metal and do not contact or attach the product with combustible objects. Failure to comply will cause fires.

 CAUTION

- Cover the top of the equipment with a piece of cloth or paper during installation. This is to prevent unwanted objects such as metal chippings, oil, and water from falling into the equipment and causing faults. After installation, remove the cloth or paper on top of the equipment to prevent over-temperature caused by poor ventilation due to blocked ventilation holes.
- Resonance may occur when the equipment operating at a constant speed executes variable speed operations. In this case, install the vibration-proof rubber under the motor frame or use the vibration suppression function to reduce resonance.

Wiring

 DANGER

- Equipment installation, wiring, maintenance, inspection, or parts replacement must be performed only by professionals.
- Before wiring, cut off all the power supplies of the equipment, and wait for at least the time designated on the equipment warning label before further operations because residual voltage still exists after power-off. After waiting for the designated time, measure the DC voltage in the main circuit to ensure the DC voltage is within the safe voltage range. Failure to comply will result in an electric shock.
- Do not perform wiring, remove the equipment cover, or touch the circuit board with power ON. Failure to comply will result in an electric shock.
- Check that the equipment is grounded properly. Failure to comply can result in an electric shock.

 WARNING

- Do not connect the input power supply to the output end of the equipment. Failure to comply can result in equipment damage or even a fire.
- When connecting a drive to the motor, check that the phase sequences of the drive and motor terminals are consistent to prevent reverse motor rotation.
- Cables used for wiring must meet cross sectional area and shielding requirements. The shield of the cable must be reliably grounded at one end.
- Fix the terminal screws with the tightening torque specified in the user guide. Improper tightening torque may overheat or damage the connecting part, resulting in a fire.
- After wiring is done, check that all cables are connected properly and no screws, washers or exposed cables are left inside the equipment. Failure to comply may result in electric shock or equipment damage.

 CAUTION

- Follow the proper electrostatic discharge (ESD) procedure and wear an anti-static wrist strap to perform wiring. Failure to comply may result in damage to the equipment or to the internal circuit of the product.
- Use shielded twisted pairs for the control circuit. Connect the shield to the grounding terminal of the equipment for grounding purpose. Failure to comply can result in equipment malfunction.

Power-on

 **DANGER**

- Before power-on, check that the equipment is installed properly with reliable wiring and the motor can be restarted.
- Check that the power supply meets equipment requirements before power-on to prevent equipment damage or a fire.
- Do not open the cabinet door or protective cover of the product, contact any wiring terminal of the product, or remove any part of the product at power-on. Failure to comply will result in an electric shock.

 **WARNING**

- Perform a trial run after wiring and parameter setting to ensure the equipment operates safely. Failure to comply may result in personal injuries or equipment damage.
- Before power-on, check that the rated voltage of the equipment is consistent with that of the power supply. Failure to comply may result in a fire accident.
- Before power-on, check that no one is near the equipment, motor, or machine. Failure to comply may result in death or personal injury.

Operation **DANGER**

- The equipment must be operated only by professionals. Failure to comply can result in death or personal injury.
- Do not touch any connecting terminals or disassemble any unit or component of the equipment during operation. Failure to comply can result in an electric shock.

 **WARNING**



- Do not touch the equipment casing, fan, or resistor with bare hands to feel the temperature. Failure to comply may result in personal injuries.
- Prevent metal or other objects from falling into the equipment during operation. Failure to comply may result in a fire or equipment damage.

Maintenance **DANGER**

- Equipment installation, wiring, maintenance, inspection, or parts replacement must be performed only by professionals.
- Do not maintain the equipment with power ON. Failure to comply can result in an electric shock.
- Before maintenance, cut off all the power supplies of the equipment and wait for at least the time designated on the equipment warning label.
- In case of a permanent magnet motor, do not touch the motor terminals immediately after power-off because the motor terminals will generate induced voltage during rotation even after the equipment power supply is off. Failure to comply will result in an electric shock.



 **WARNING**

- Perform routine and periodic inspection and maintenance on the equipment according to maintenance requirements and keep a maintenance record.

Repair	
 DANGER	<ul style="list-style-type: none"> • Equipment installation, wiring, maintenance, inspection, or parts replacement must be performed only by professionals. • Do not repair the equipment with power ON. Failure to comply can result in an electric shock. • Before inspection and repair, cut off all the power supplies of the equipment and wait for at least the time designated on the equipment warning label.
 WARNING	<ul style="list-style-type: none"> • Submit the repair request according to the warranty agreement. • When the fuse is blown or the circuit breaker or residual current device (RCD) trips, wait for at least the time designated on the equipment warning label before power-on or further operations. Failure to comply may result in death, personal injury or equipment damage. • When the equipment is faulty or damaged, the troubleshooting and repair work must be performed by professionals that follow the repair instructions, with repair records kept properly. • Replace quick-wear parts of the equipment according to the replacement instructions. • Do not operate on damaged equipment. Failure to comply may result in death, personal injury, or severe equipment damage. • After the equipment is replaced, check the wiring and set parameters again.
Disposal	
 WARNING	<ul style="list-style-type: none"> • Dispose of retired equipment in accordance with local regulations and standards. Failure to comply may result in property damage, personal injury, or even death. • Recycle retired equipment by observing industry waste disposal standards to avoid environmental pollution.

Safety Labels

For safe operation and maintenance, comply with the safety labels on the equipment. Do not damage or remove the safety labels. See the following table for descriptions of the safety labels.

Safety Label		Description
T12 models and below	T13 models	
		<ul style="list-style-type: none"> • Read through the safety instructions before operating the equipment. Failure to comply may result in death, personal injuries, or equipment damage. • Do not touch the terminals or remove the cover with power ON or within 10 min (for T12 models and below) or 15 min (for T13 models) after power-off. Failure to comply will result in an electric shock.

Product Model List

The following table lists the mapping between product models and structures.

Table –1 Mapping between product models and structures

Structure	Product Model		
	Three-Phase 380 V to 480 V	Three-Phase 200 V to 240 V	Single-Phase 200 V to 240 V
T1	MD520-4T0.4B(S) MD520-4T0.7B(S) MD520-4T1.1B(S) MD520-4T1.5B(S) MD520-4T2.2B(S) MD520-4T3.0B(S)	MD520-2T0.4B(S) MD520-2T0.7B(S) MD520-2T1.1B(S) MD520-2T1.5B(S)	-
T2	MD520-4T3.7B(S) MD520-4T5.5B(S)	MD520-2T2.2B(S) MD520-2T3.7B(S)	MD520-2S0.4B(S) MD520-2S0.7B(S) MD520-2S1.5B(S) MD520-2S2.2B(S)
T3	MD520-4T7.5B(S) MD520-4T11B(S)	MD520-2T5.5B(S)	-
T4	MD520-4T15B(S)	MD520-2T7.5B(S)	-
T5	MD520-4T18.5(B)(S)(-T) MD520-4T22(B)(S)(-T)	MD520-2T11(B)(S)	-
T6	MD520-4T30(B)(S) MD520-4T37(B)(S)	MD520-2T15(B)(S) MD520-2T18.5(B)(S)	-
T7	MD520-4T45(B)(S) MD520-4T55(B)(S)	MD520-2T22(B)(S) MD520-2T30(B)(S)	-
T8	MD520-4T75(B)(S) MD520-4T90(S) MD520-4T110(S)	MD520-2T37(B)(S) MD520-2T45(S) MD520-2T55(S)	-
T9	MD520-4T132(S) MD520-4T160(S)	MD520-2T75(S)	-
T10	MD520-4T200(S)(-L) MD520-4T220(S)(-L)	MD520-2T90(S) MD520-2T110(S)	-
T11	MD520-4T250(S)(-L) MD520-4T280(S)(-L)	MD520-2T132(S)	-
T12	MD520-4T315(S)(-L) MD520-4T355(S)(-L) MD520-4T400(S)(-L)	MD520-2T160(S) MD520-2T200(S)	-
T13 (without the auxiliary power distribution cabinet)	MD520-4T500 MD520-4T500(S) MD520-4T560 MD520-4T560(S) MD520-4T630 MD520-4T630(S)	-	-

Structure	Product Model		
	Three-Phase 380 V to 480 V	Three-Phase 200 V to 240 V	Single-Phase 200 V to 240 V
T13 (with the auxiliary power distribution cabinet)	MD520-4T500-A MD520-4T500(S)-A MD520-4T560-A MD520-4T560(S)-A MD520-4T630-A MD520-4T630(S)-A	-	-
<p>Note:</p> <ul style="list-style-type: none"> ● (B): with the braking unit ● (S): with the safe torque off (STO) function ● (-T): with the DC reactor ● (-L): with the AC output reactor 			

1 Mechanical Installation

1.1 T1 to T9 Model Installation

1.1.1 Dimensions of T1 to T9 Models

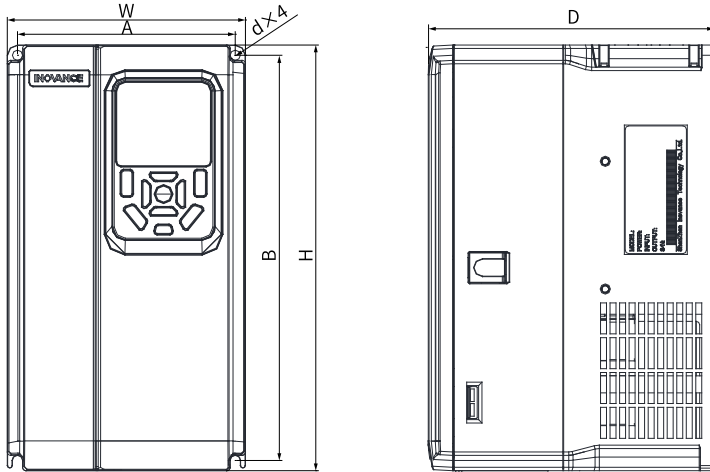

Figure 1-1 Outline dimensions and mounting dimensions of T1 to T4 models

Table 1-1 Outline dimensions and mounting dimensions of T1 to T4 models

Structure	Mounting Hole Dimension mm (in.)		Overall Dimension mm (in.)			Mounting Hole Diameter mm (in.)	Weight kg (lb)
	A	B	H	W	D		
T1	119 (4.7)	189 (7.5)	200 (7.9)	130 (5.1)	150 (6.0)	Φ5 (0.2)	1.6 (3.5)
T2	119 (4.7)	189 (7.5)	200 (7.9)	130 (5.1)	160 (6.4)	Φ5 (0.2)	2.0 (4.4)
T3	128 (5.0)	238 (9.4)	250 (9.9)	140 (5.5)	168.3 (6.7)	Φ6 (0.2)	3.3 (7.3)
T4	166 (6.5)	266 (10.5)	280 (11.0)	180 (7.1)	169 (6.7)	Φ6 (0.2)	4.3 (9.5)

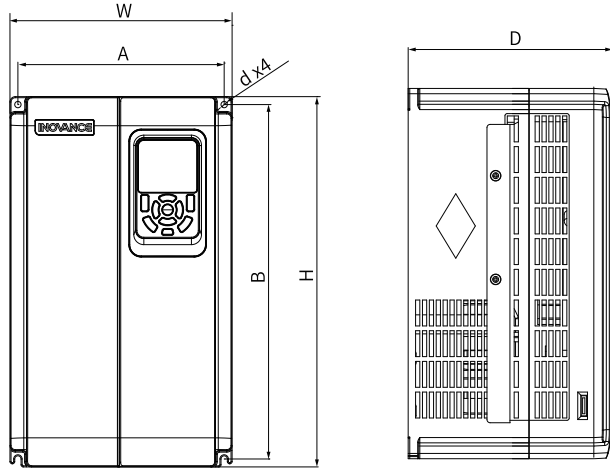

Figure 1-2 Outline dimensions and mounting dimensions of T5 and T6 models

Table 1-2 Outline dimensions and mounting dimensions of T5 to T6 models

Structure	Mounting Hole Dimension mm (in.)		Overall Dimension mm (in.)				Mounting Hole Diameter mm (in.)	Weight kg (lb)
	A	B	H	H1	W	D	d x 4	
T5 (without the DC reactor)	195 (7.7)	335 (13.2)	350 (13.8)	-	210 (8.3)	193.4 (7.6)	Φ6 (0.2)	7.6 (16.8)
T5 (-T models come with the DC reactor)	195 (7.7)	335 (13.2)	350 (13.8)	-	210 (8.3)	193.4 (7.6)	Φ6 (0.2)	10.0 (22.0)
T6	230 (9.1)	380 (15.0)	400 (15.8)	-	250 (9.9)	220.8 (8.7)	Φ7 (0.3)	17.5 (38.6)

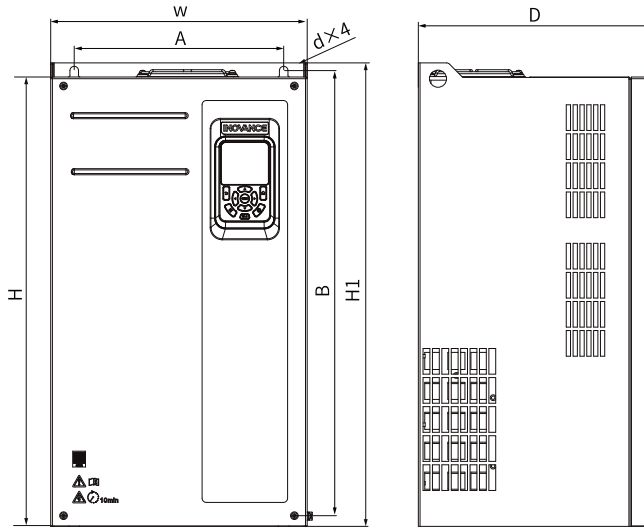

Figure 1-3 Outline dimensions and mounting dimensions of T7 and T9 models

Table 1-3 Outline dimensions and mounting dimensions of T7 to T9 models

Structure	Mounting Hole Dimension mm (in.)		Overall Dimension mm (in.)				Mounting Hole Dimension mm (in.)	Weight kg (lb)
	A	B	H	H1	W	D	d x 4	
T7	245 (9.7)	523 (20.6)	525 (20.7)	542 (21.4)	300 (11.8)	275 (10.8)	Φ10 (0.4)	35 (77.2)
T8	270 (10.6)	560 (22.1)	554 (21.8)	580 (22.9)	338 (13.3)	315 (12.4)	Φ10 (0.4)	51.5 (113.5)
T9	320 (12.6)	890 (35.1)	874 (34.4)	915 (36.1)	400 (15.8)	320 (12.6)	Φ10 (0.4)	85 (187.4)

1.1.2 Backplate Mounting

Fix the AC drive with all nuts. Do not fasten only the upper two nuts on the drive. Otherwise, the drive may fall off due to uneven force during long-time running.

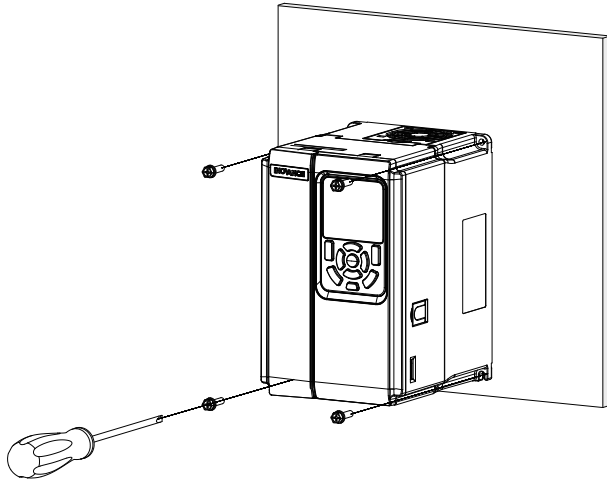

Figure 1-4 Backplate mounting of T1 and T6 models

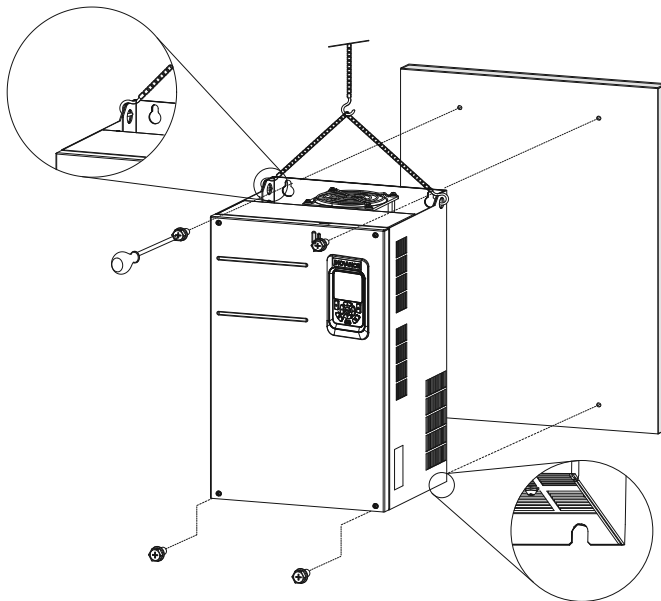
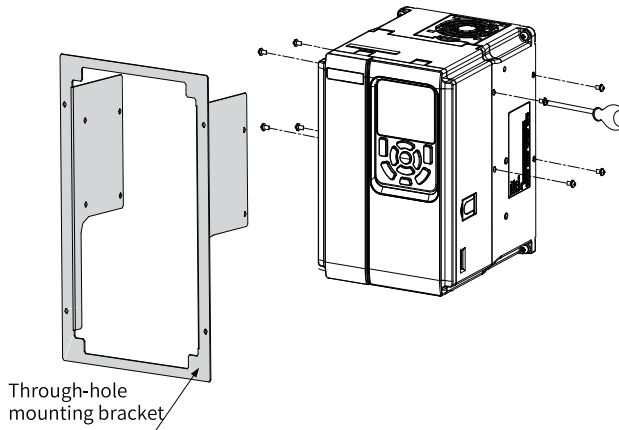

Figure 1-5 Backplate mounting of T7 and T9 models

1.1.3 Through-Hole Mounting

T1 to T6 models

1. Install the AC drive through the mounting bracket, and then fix the screws at both sides of the bracket.



The following figure shows an AC drive with a bracket mounted.

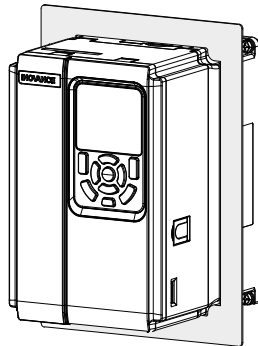

2. Fix the AC drive with the bracket on the backplate of the control cabinet.

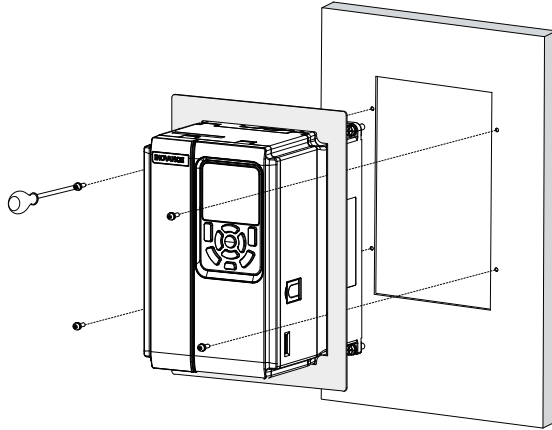

The following figure shows an AC drive with the bracket mounted in the cabinet.

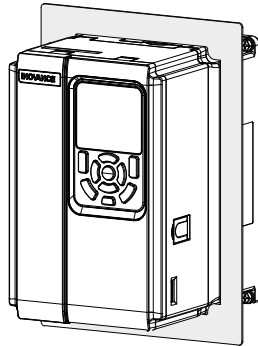

T7 to T9 models

1. Fix the through-hole mounting bracket from both sides of the enclosure.

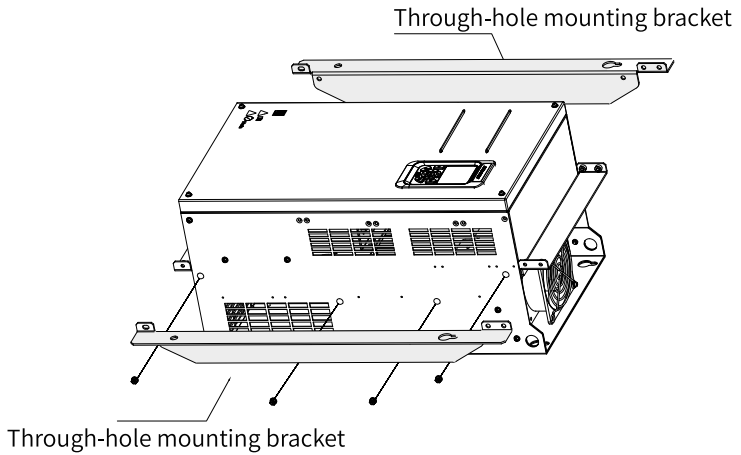

The following figure shows an AC drive with brackets mounted.

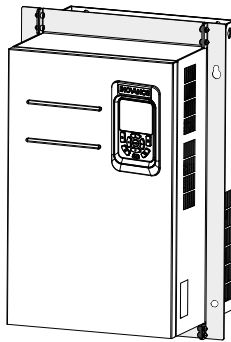

2. Fix the drive with brackets to the backplate of the control cabinet.

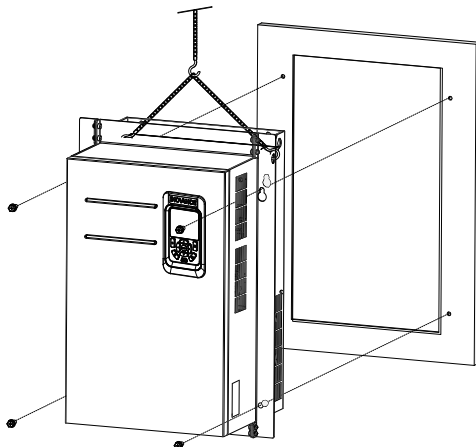

The following figure shows an AC drive with the bracket mounted in the cabinet.

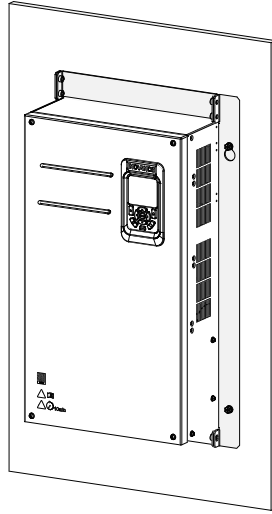

1.2 T10 to T12 Model Installation

1.2.1 Dimensions of T10 to T12 Models (Without AC Output Reactor)

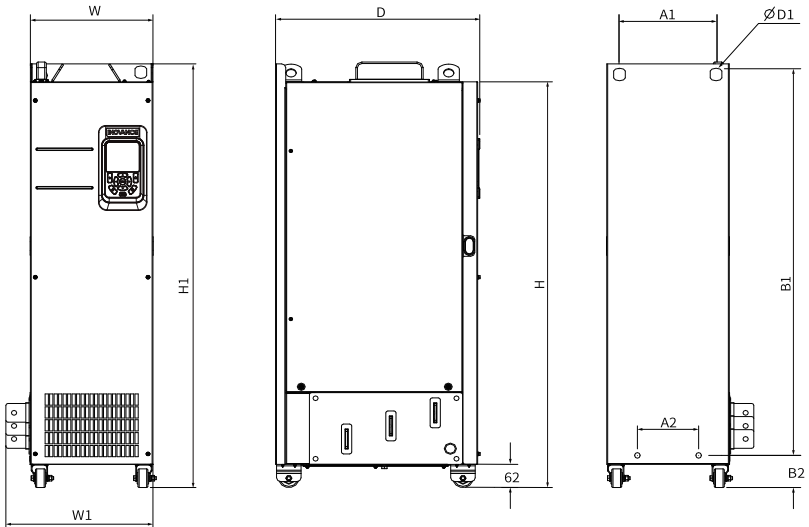

Figure 1-6 Outline dimensions and mounting dimensions of T10 to T12 models (without AC output reactors)

Table 1-4 Outline dimensions and mounting dimensions of T10 to T12 models (without AC output reactors)

Structure	Mounting Hole Dimension mm (in.)				Overall Dimension mm (in.)					Mounting Hole Diameter mm (in.)	Weight kg (lb)
	A1	A2	B1	B2	H	H1	W	W1	D		
T10	240 (9.5)	150 (5.9)	1035 (40.8)	86 (3.4)	1086 (42.8)	1134 (44.7)	300 (11.8)	360 (14.2)	500 (19.7)	φ13 (0.5)	110 (242.5)
T11	225 (8.9)	185 (7.3)	1175 (46.3)	97 (3.8)	1248 (49.2)	1284 (50.6)	330 (13)	390 (15.4)	545 (21.5)	φ13 (0.5)	155 (341.7)
T12	240 (9.5)	200 (7.9)	1280 (50.4)	101 (4)	1355 (53.4)	1405 (55.4)	340 (13.4)	400 (15.8)	545 (21.5)	φ16 (0.6)	185 (407.9)

1.2.2 Dimensions of T10 to T12 Models (with AC Output Reactor)

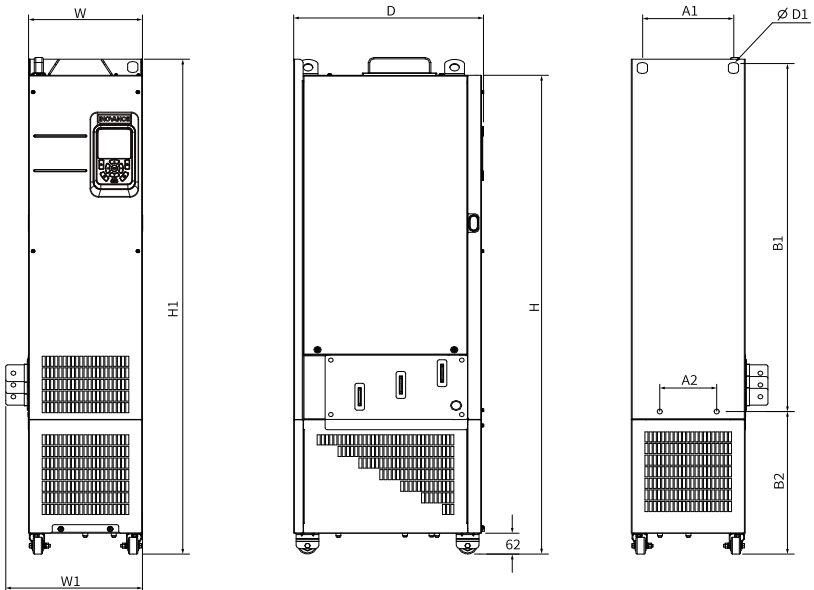

Figure 1-7 Outline dimensions and mounting dimensions of T10 to T12 models (with AC output reactors)

Table 1-5 Outline dimensions and mounting dimensions of T10 to T12 models (with AC output reactor)

Structure	Mounting Hole Diameter mm (in.)				Overall Dimension mm (in.)					Mounting Hole Diameter mm (in.)	Weight kg (lb)
	A1	A2	B1	B2	H	H1	W	W1	D	D1	
T10	240 (9.5)	150 (5.9)	1035 (40.8)	424 (16.7)	1424 (56.1)	1472 (58.0)	300 (11.8)	360 (14.2)	500 (19.7)	φ13 (0.5)	160 (352.7)
T11	225 (8.9)	185 (7.3)	1175 (46.3)	435 (17.1)	1586 (62.5)	1622 (63.9)	330 (13.0)	390 (15.4)	545 (21.5)	φ13 (0.5)	215 (474.0)
T12	240 (9.5)	200 (7.9)	1280 (50.4)	432 (17.0)	1683 (66.3)	1733 (68.3)	340 (13.4)	400 (15.8)	545 (21.5)	φ16 (0.6)	245 (540.1)

1.2.3 Installation Within the Cabinet

Context

The nine-fold profile cabinet (PS cabinet) is recommended. This kind of cabinet is in an assembled structure, which is cost effective. The openings on the main column of the cabinet meet the general standards, facilitating the design of mounting beams and structure strengthening. In summary, the nine-fold profile cabinet is a kind of industrial standard cabinet with high reliability. "Figure 1-8" on page 24 shows the cross section of the nine-fold profile cabinet.

Procedure

1. In the nine-fold profile cabinet (PS cabinet), install the mounting beam for fixing the AC drive and reserve fixed holes.

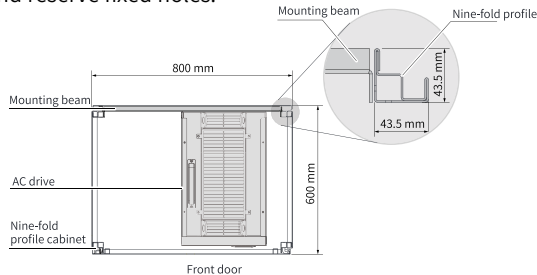

Figure 1-8 Top view of the cabinet for T11 and T12 models

To install T11 to T12 models into the nine-fold profile cabinet with the depth of 600 mm, bend the back mounting board inwards (not required for the cabinet with the depth of 800 mm), as shown in "Figure 1-9" on page 25. However, if the cabinet with the depth of 600 mm has both front and back doors, the AC drive cannot be

installed in this kind of cabinet. Instead, install the AC drive into the cabinet with the depth of 800 mm.

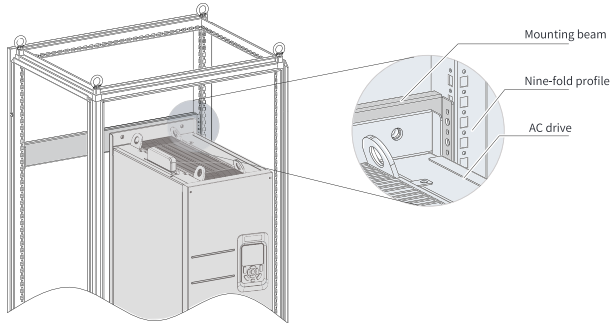

Figure 1-9 3D of the cabinet for T11 and T12 models

2. Fix the bottom mounting bracket in the nine-fold profile cabinet.
Fix the mounting bracket to the base of the nine-fold profile cabinet by using six M5 self-tapping screws, as shown in ["Figure 1-10 " on page 25](#).

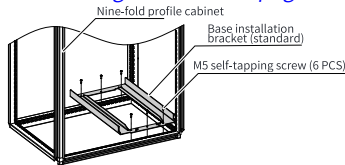

Figure 1-10 Installing the bottom mounting bracket

Note

Drill holes for the mounting bracket and assemble the bracket on site if the cabinet is not a nine-fold profile one.

3. Assemble the guide rails (model: MD500-AZJ-A3T10) and mount the guide rail assembly to the cabinet.
 - a. Assemble the guide rail, as shown in ["Figure 1-11 " on page 26](#).

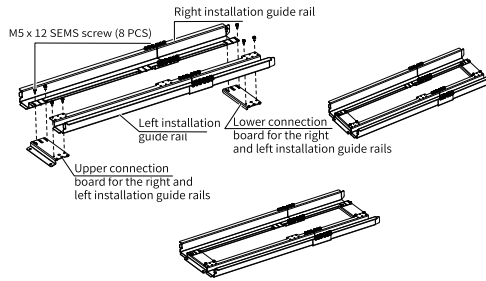

Figure 1-11 Assembling guide rails

- b. Align the two round holes at the front end of the mounting rail with the screws of the mounting bracket, and then lock the guide rail to the cabinet with two M6 nuts, as shown in "Figure 1-12" on page 26.

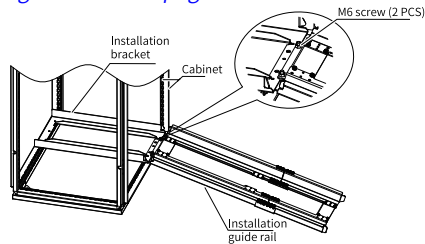

Figure 1-12 Mounting the guide rails to the cabinet

4. Remove the cover from the AC drive.
For details, see "[1.2.4.1 Removing the Cover](#)" on page 29. After the cover is removed, the auxiliary handle will be exposed.
5. Align the casters of the AC drive with the guide rails and gently push the AC drive into the cabinet.
During the push-in or pull-out process, use the auxiliary strap to prevent the drive from toppling over. It is recommended that two people work together.

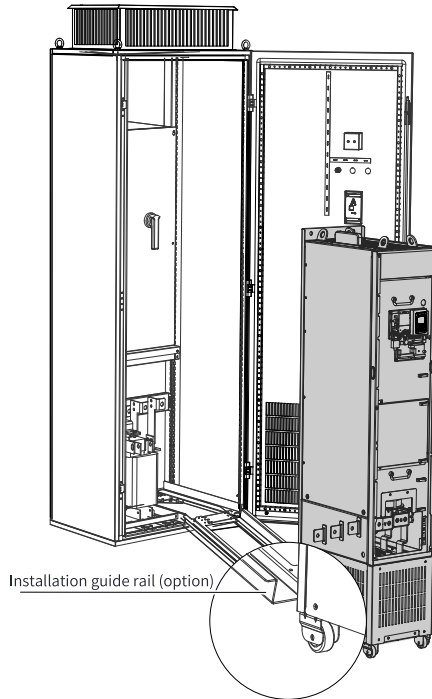

Figure 1-13 Aligning the AC drive castor with the guide rail

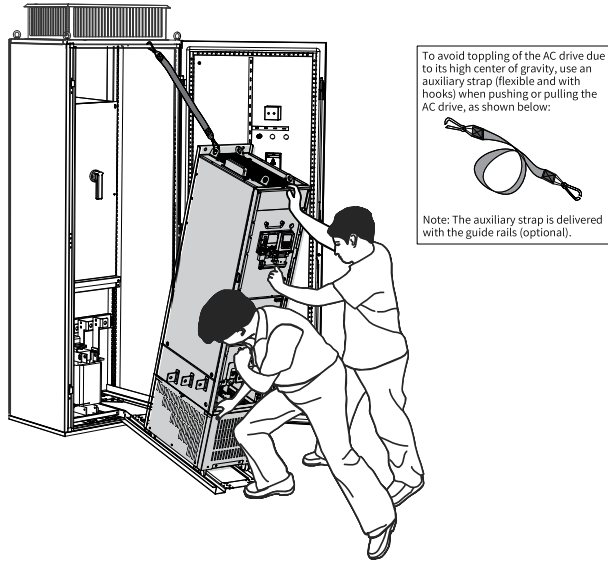

Figure 1-14 Pushing the AC drive into the cabinet

6. Remove the auxiliary strap, install the four screws on the back of the AC drive to fix it to the beam in the cabinet.

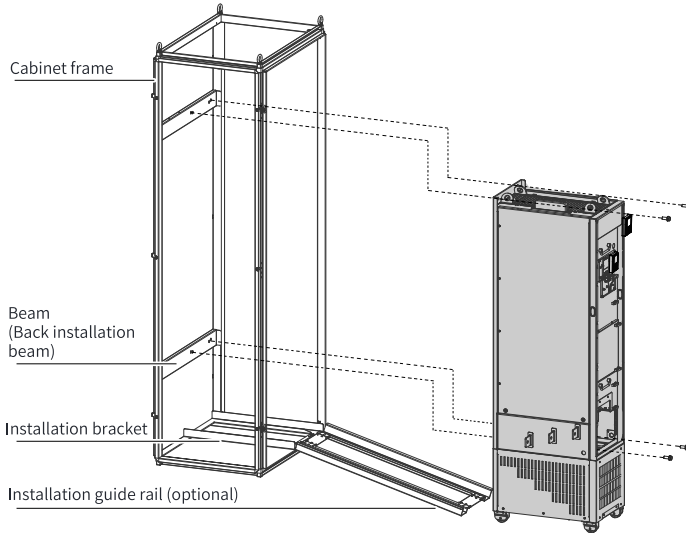

Figure 1-15 Installing the AC drive to the beam

7. After installation is done, remove the guide rail.
8. Remove the air filter paper board at the top of the AC drive. The air filter paper board is used to prevent foreign objects such as screws from falling into the air filter during installation of the AC drive into the cabinet.

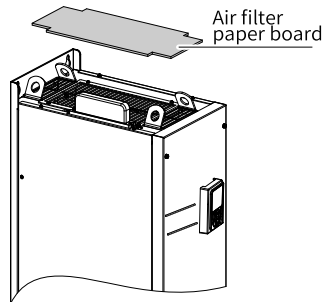

Figure 1-16 Removing the air filter paper board

1.2.4 Cover Removal and Installation

1.2.4.1 Removing the Cover

Before wiring the control circuit, such as operating jumpers or connecting PG cards or expansion cards, remove the cover from the AC drive. When removing the cover, hold the cover with your hands and carefully lift the lower part of the cover to prevent it from falling off. Failure to comply will result in equipment damage or personal injury.

Prerequisites

Before removing the cover, ensure that the machine has been powered off for over 10 minutes.

Procedure

1. Use a screwdriver to remove the six fixing screws on the cover.

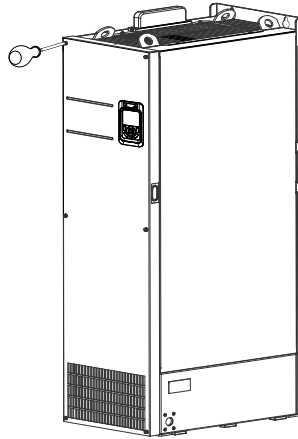

2. Hold the cover with both hands, and lift it up in the direction indicated by the arrow to remove it.

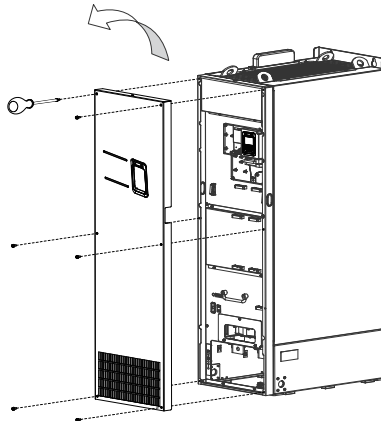

1.2.4.2 Installing the Cover

The cover of the AC drive must be removed before wiring the main circuit and control circuit. After wiring is done, re-install the cover.

Procedure

1. Hold the cover with both hands, align the upper edge of the cover with the upper edge snap-fit joint on the chassis, and snap them together, as shown in the following figure. Then align the six screw mounting holes in the cover with the cover fixing holes in the chassis and press them tightly against each other.

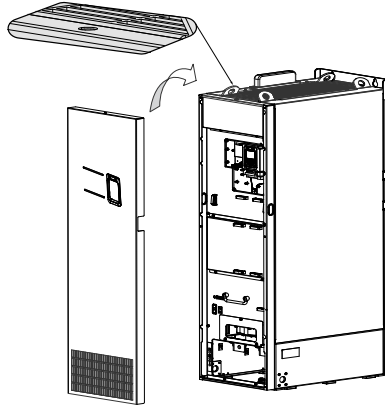

2. Install six fixing screws into the holes with a screwdriver to fasten the cover.

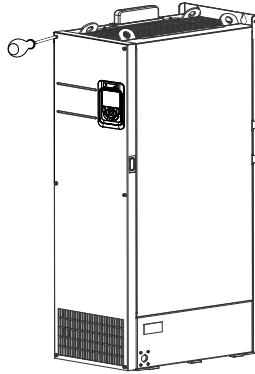

1.3 T13 Model Installation

1.3.1 Dimensions of T13 Models (Without Auxiliary Power Distribution Cabinet)

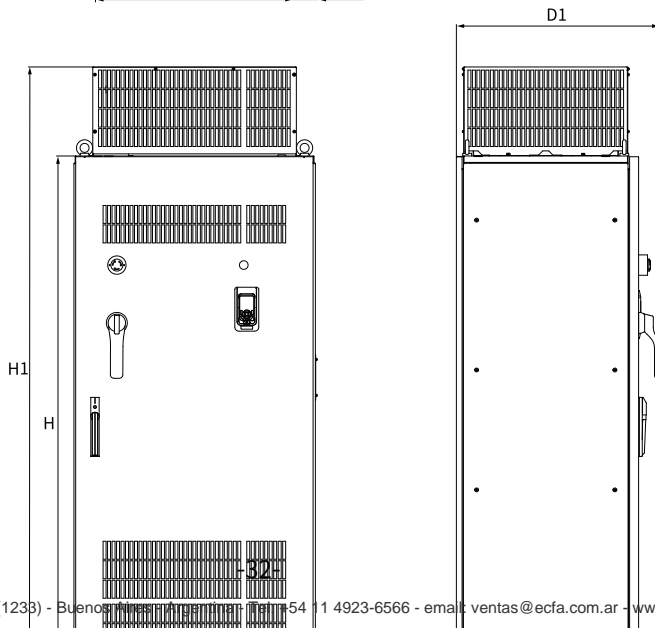
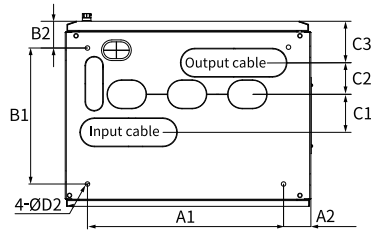

Figure 1-17 Outline dimensions and mounting dimensions of T13 models (without auxiliary power distribution cabinet)

Table 1-6 Outline dimensions and mounting dimensions of T13 models (without auxiliary power distribution cabinet)

Structure	Mounting Hole Dimension mm (in.)						
	A1	A2	B1	B2	C1	C2	C3
T13	660 (26.0)	73.5 (2.9)	450 (17.7)	85 (3.3)	125 (4.9)	104 (4.1)	136 (5.4)

Structure	Overall Dimension mm (in.)					Mounting Hole Diameter mm (in.)	Weight kg (lb)
	H	H1	W	D	D1		
T13	1800 (70.9)	2100 (82.7)	805 (31.7)	610 (24.0)	680 (26.8)	15 (0.6)	530 (1168.4)

1.3.2 Dimensions of T13 Models (with Auxiliary Power Distribution Cabinet)

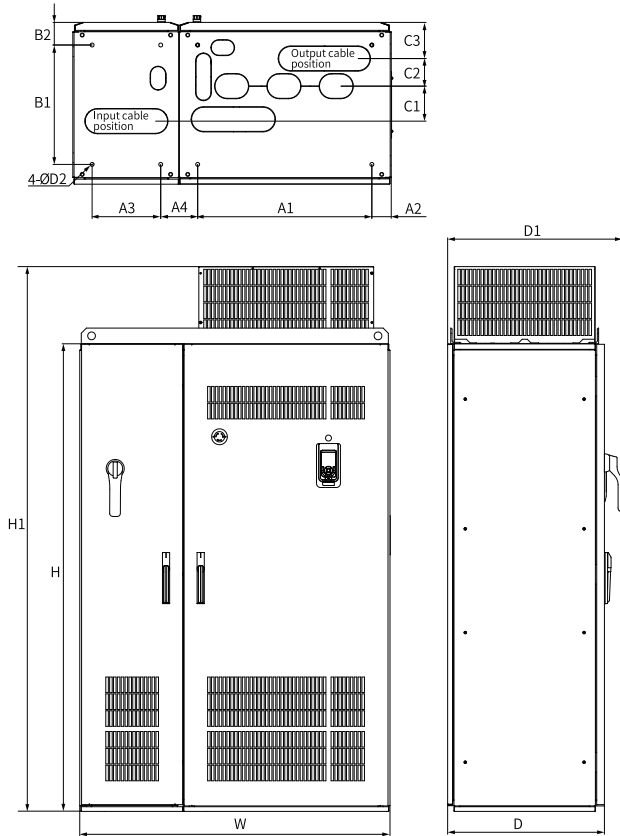

Figure 1-18 Outline dimensions and mounting dimensions of T13 models (with auxiliary power distribution cabinet)

Table 1-7 Outline dimensions and mounting dimensions of T13 models (with auxiliary power distribution cabinet)

Structure	Mounting Hole Dimension mm (in.)								
	A1	A2	A3	A4	B1	B2	C1	C2	C3
T13	660 (26.0)	73.5 (2.9)	260 (10.2)	140 (5.5)	450 (17.7)	85 (3.3)	132 (5.2)	104 (4.1)	136 (5.4)

Structure	Overall Dimension mm (in.)					Mounting Hole Diameter mm (in.)	Weight kg (lb)
	H	H1	W	D	D1		
T13	1800 (70.9)	2100 (82.7)	1205 (47.5)	610 (24.0)	680 (26.8)	15 (0.6)	730 (1609.4)

1.3.3 Requirements on Ground Levelness

- The installation base must be level and firm enough to bear the weight of the cabinet.
- Use the door lock in a proper way to open and close the cabinet unit.
- Ensure there is no gap between the cabinet and the ground when cabinets are connected side by side. For any inevitable gap (shown by ①), use a pad (shown by ②) to level the cabinet, and use proper fillings (for example, fireproof mud) to fill the gap.

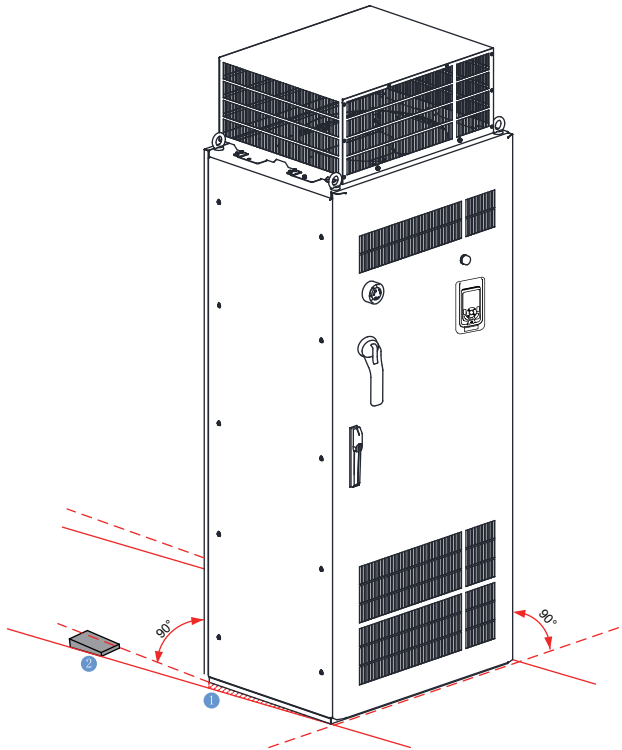

Figure 1-19 Ground requirements

1.3.4 Expansion Screw Installation

To install the cabinet on a cement floor, embed expansion nuts in advance in the floor at positions corresponding to the fixing holes of the cabinet for fixing the cabinet.

The following figure shows the steps of installing expansion screws, where ❶ indicates an expansion screw, ❷ indicates the cabinet, and ❸ indicates an M12 bolt.

1. Drill a hole for the expansion screw. The hole diameter shall be slightly smaller than the maximum outer diameter of the screw, and the hole depth shall be greater than the expansion screw length. The expansion screw must be vertical to the ground, as shown by Step 1 in the following figure.
2. The expansion screw consists of a bolt spring enclosure and a screw part. Use a hammer to knock the expansion screw into the hole and ensure that the screw head is below the ground surface, as shown by Step 2 in the following figure.
3. After placing the cabinet in the required position, fasten it with M12 bolts. The expansion screw stem will be pulled up, making the spring shell deform to fasten the cabinet, as shown in Step 3.

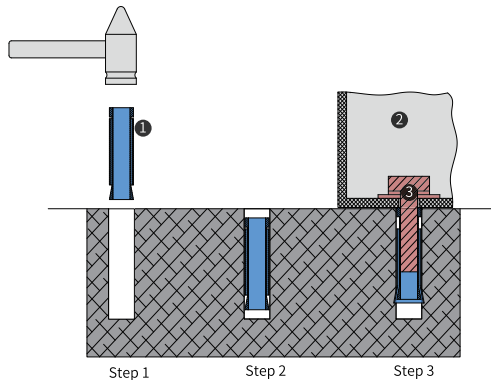

Figure 1-20 Installing an expansion screw

1.3.5 Requirements on foundation

- Separate high-voltage cables from low-voltage cables by using different brackets. If they cannot be separated, lay low-voltage cables in fully-enclosed metal ducts.
- The cable tray must be made of non-flammable materials and must be smooth, damp-proof, dust-proof, and rat-proof.
- During foundation design, take the following factors into consideration: sufficient space in front of the cabinet for inspection, and wiring and cabling of power supply cables, actuating motor cables, and system control cables. The cabinet comes with a cable tray or cable guide. Separate power cables from signal cables. Failure to comply will affect the operation of the AC drive. The following figure shows the routing and related requirements.

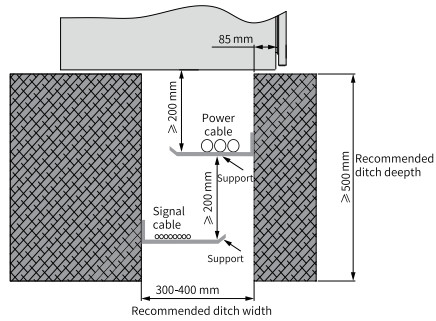
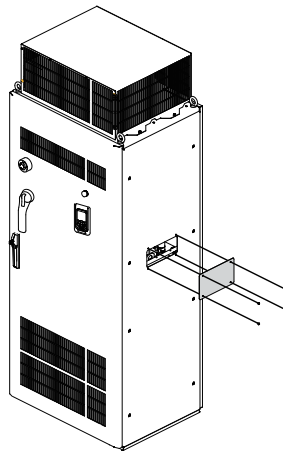

Figure 1-21 Foundation layout

1.3.6 External Braking Unit Installation

Procedure

1. Remove the lateral closure plate of the cabinet.



2. Open the cabinet door and mount the adapter busbar for the external braking unit, as shown in the following figure.

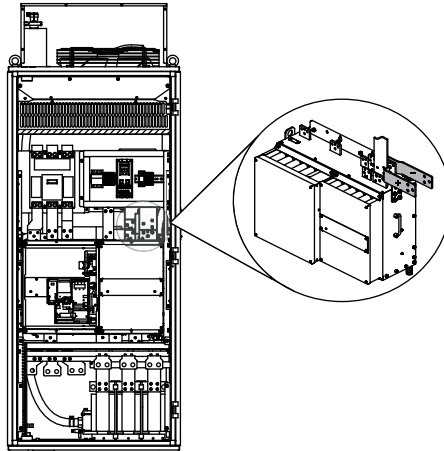

3. Connect the AC drive to the external braking unit.

Note

The number of required braking units is subject to actual conditions. When multiple braking units are required, connect them in parallel. The following figure takes one braking unit as an example.

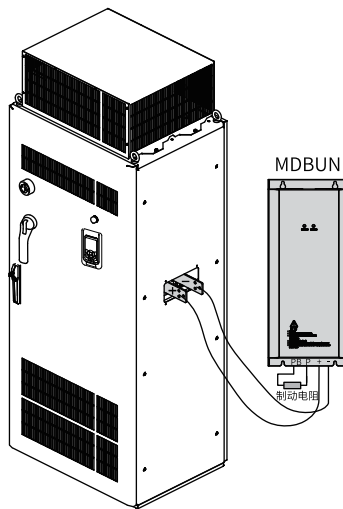

Figure 1-22 Connecting the AC drive to the external braking unit

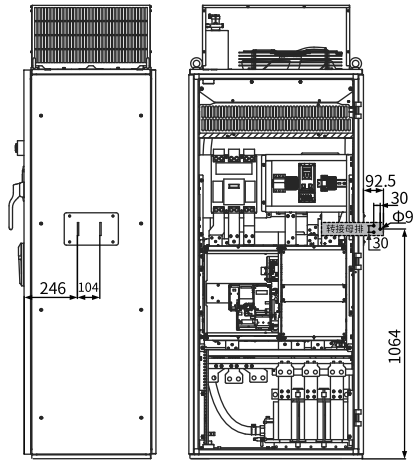

Figure 1-23 Dimensions of the position for installing the adapter busbar (unit: mm)

2 Electrical Installation

2.1 Electrical Connection

T1 to T12 models

"Figure 2-1 " on page 40 shows a typical wiring method of T1 to T12 models.

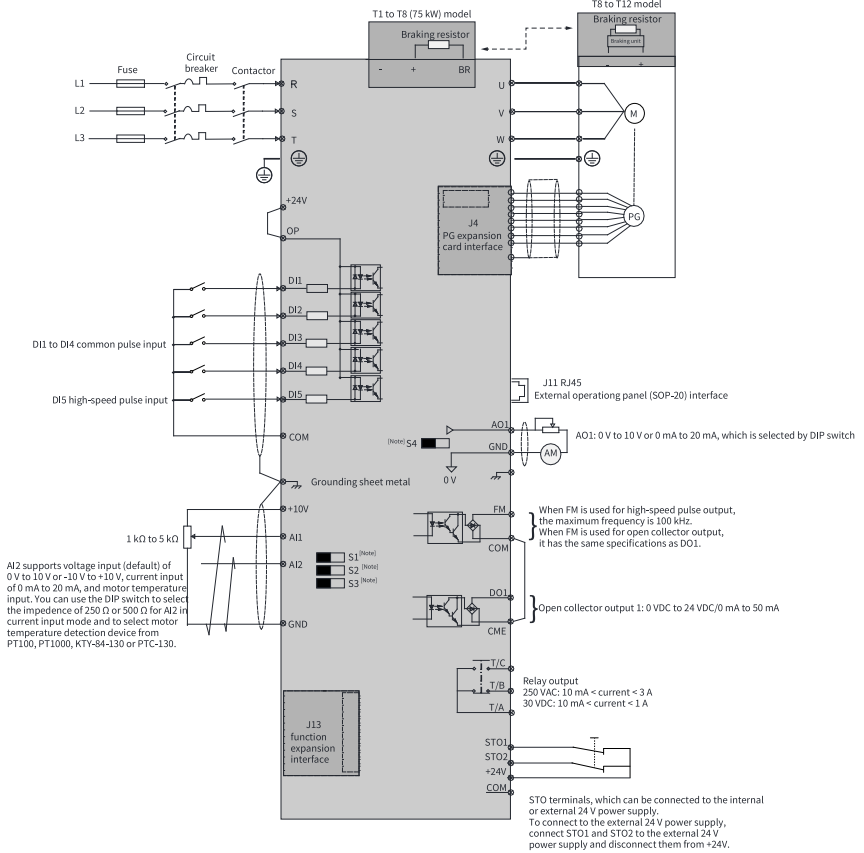

Figure 2-1 Standard wiring (T1 to T12)

Note

- For details on S1 to S4 DIP switches, see ["Table 2-4 Function description of control circuit terminals"](#) on page 47.
- For three-phase 380–480 V AC drives, a 0.4–75 kW model differs from a 90–450 kW model in the wiring detail marked by the double arrows in the figure.
- For three-phase 200–240 V AC drives, a 0.4–37 kW model differs from a 45–200 kW model in the wiring detail marked by the double arrows in the figure.

T13 models

"Figure 2-2" on page 41 shows the electrical connection in the cabinet.

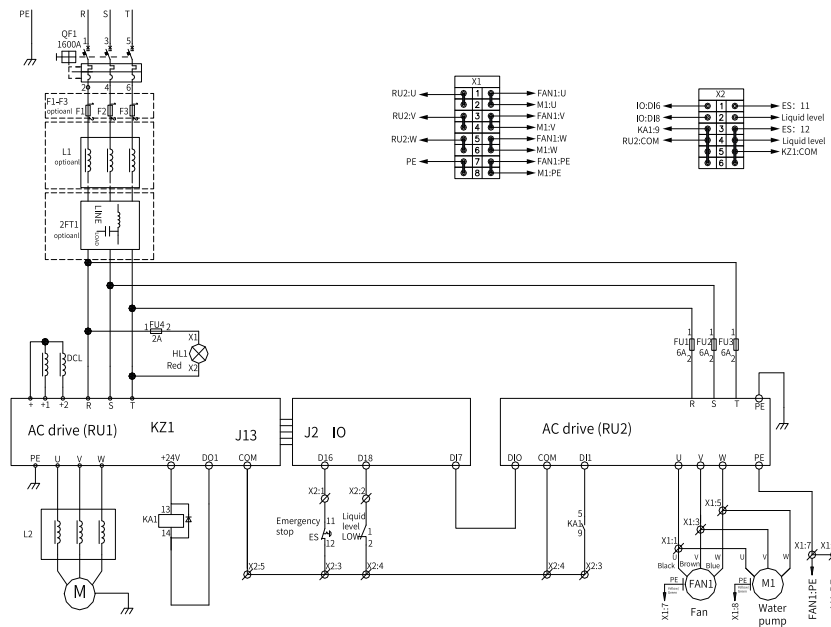

Figure 2-2 Electrical connection in the cabinet (T13)

T13 models

- The cabinet operates under high voltages. Do not attempt to connect any wires while the voltage is live.
- The cabinet can be operated only by qualified professionals.
- Take caution when operating the equipment disconnected from the power supply as external supply voltage may still be present. The main circuit and control circuit terminals may be live even when the motor is in the stop state.

- After disconnecting the input and output power supplies, wait for at least 15 minutes until the bus voltage is lower than 36 V and the power indicator is off before further operation.
- Ensure that the motors, cabinets, and other components are installed and connected in accordance with the recognized technical rules of the country and the region. Pay special attention to regulations on cable dimensions, fuses, grounding, open circuits, isolation, and overcurrent protection.
- If the fuse in a branch circuit trips, the fault current may have been disconnected. To reduce the risk of fire and electric shocks, check the conductive parts and other components of the cabinet and replace the damaged ones. After a fuse trips, identify and rectify the cause of the tripping.

2.2 Descriptions of Main Circuit Terminals

T1 to T9 models

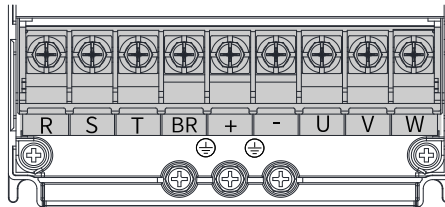

Figure 2-3 Layout of main circuit terminals for T1 to T4 models (three phase)

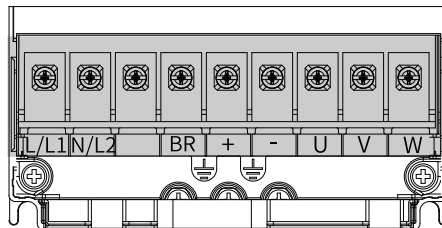

Figure 2-4 Layout of main circuit terminals for T2 models (single phase)

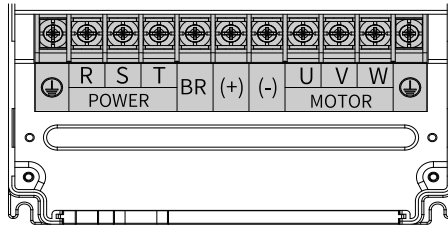

Figure 2-5 Layout of main circuit terminals for T5 to T8 models

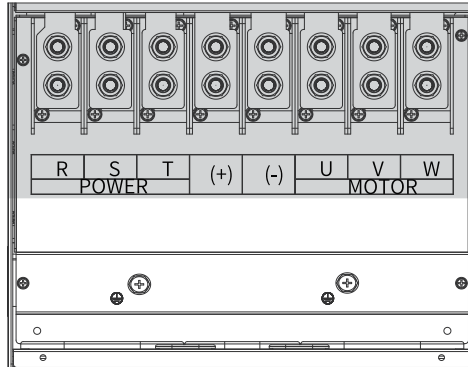



Figure 2-6 Layout of main circuit terminals for T9 models

Table 2-1 Descriptions of main circuit terminals

Terminal Mark	Terminal Name	Function Description
R, S, T	Input terminals of three-phase power supply	Used to connect the three-phase AC input power supply.
(+), (-)	Positive and negative terminals of the DC bus	Common DC busbar input; connected to the external braking unit of T9 models and above.
(+), BR	Braking resistor connection terminals	Used to connect to the braking resistor of T8 models and below. Note: Only models with the name containing "B" are equipped with brake resistor terminals. For models with the name excluding "B", external brake units are required.

Terminal Mark	Terminal Name	Function Description
U, V, W	Output terminals	Used to connect the three-phase motor.
	Grounding terminal (PE)	Used for protective grounding.

T10 to T12 models

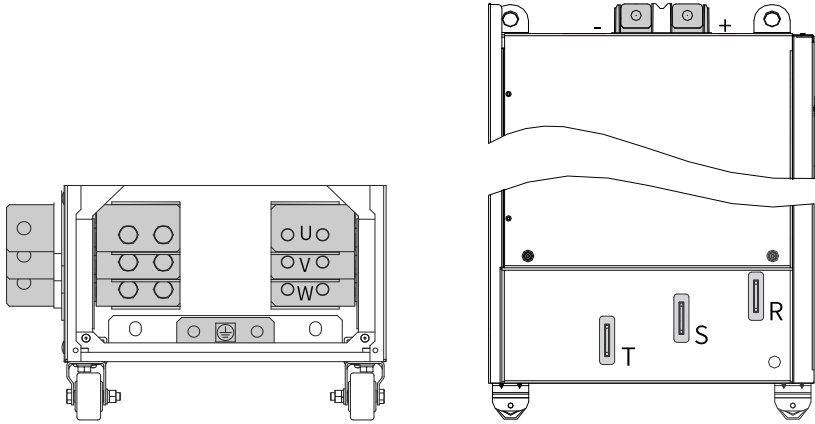



Figure 2-7 Layout of main circuit terminals for T10 to T12 models

Table 2-2 Descriptions of main circuit terminals

Terminal Mark	Terminal Name	Function Description
R, S, T	Input terminals of three-phase power supply	Used to connect the three-phase AC input power supply.
+, -	Positive and negative terminals of the DC bus	Common DC busbar input; connected to an external braking unit.
U, V, W	AC drive output terminals	Used to connect the three-phase motor.
	Grounding terminal (PE)	Used for protective grounding.



T13 models

Figure 2-8 Layout of main circuit terminals for T13 models

Table 2-3 Descriptions of main circuit terminals

Terminal Mark	Terminal Name	Function Description
R, S, T	Input terminals of three-phase power supply	Used to connect the three-phase AC input power supply.
+, -	Positive and negative terminals of the DC bus	Common DC busbar input; connected to an external braking unit.
U, V, W	AC drive output terminals	Used to connect the three-phase motor.
	Grounding terminal (PE)	Used for protective grounding.

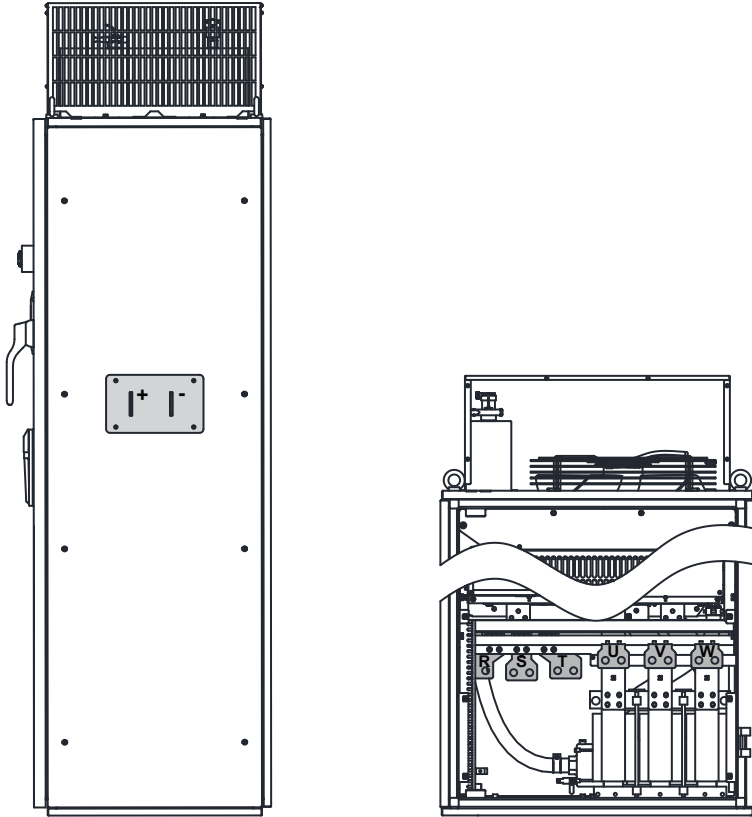
2.3 Descriptions of Control Circuit Terminals

"Table 2-6 " on page 49 shows the layout of control circuit terminals.

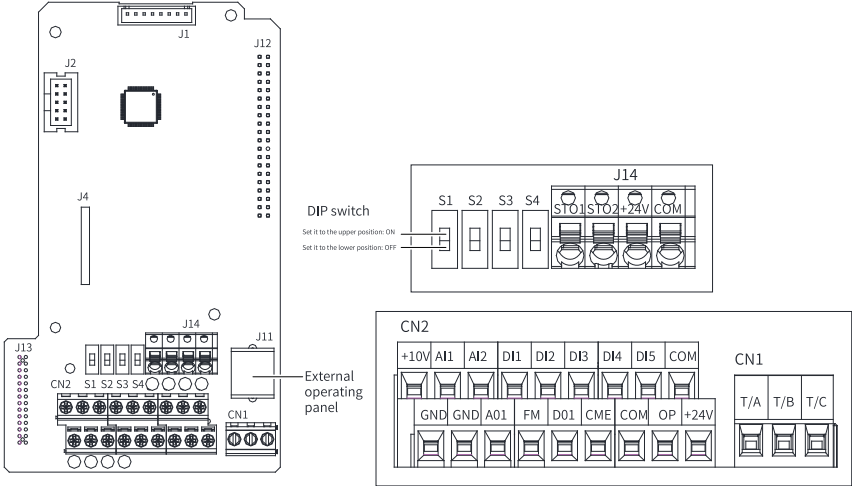

Figure 2-9 Layout of control circuit terminals

Table 2-4 Function description of control circuit terminals

Type	Terminal Mark	Terminal Name	Function Description
Power supply	+10V-GND	External +10 V power supply	The terminal is used to provide +10 V power supply to an external unit with the maximum output current of 10 mA. Generally, it is used to power an external potentiometer with resistance ranging from 1 k Ω to 5 k Ω .
	+24V-COM	External +24 V power supply	The terminal is used to provide +24 V power supply to external devices. Generally, it is used to power the DI5/DO5 and external sensor. The maximum output current is 200 mA ^[Note 1] .
	OP	Input terminal for external power supply	It is connected to +24V by default. When DI1 to DI5 are driven by external signals, OP must be disconnected from +24 V and connected to the external power supply.
Analog input	AI1-GND	AI1	Input voltage range: -10 VDC to +10 VDC Input impedance: 22 k Ω
	AI2-GND	AI2	The terminal supports voltage input (default), current input, and temperature input. When used as voltage/current input, the terminal supports 0 V to 10 V, -10 V to +10 V, or 0 mA to 20 mA, and supports 12-bit resolution and the correction accuracy of 1%. The input impedance is 22 k Ω for voltage input and 500 Ω or 250 Ω for current input, which is set by S2 and S3 DIP switches ^{Note [2]} .
Digital input	DI1-OP	DI1	Photocoupler isolation, compatible with dual-polarity input.
	DI2-OP	DI2	
	DI3-OP	DI3	Input impedance: 1.72 k Ω
	DI4-OP	DI4	Operating voltage range: 9 V to 30 V
	DI5-OP	DI5	Besides features of DI1 to DI4, DI5 can also be used for high-speed pulse input. Input impedance: 1.16 k Ω Maximum input frequency: 100 kHz Operating voltage range: 15 V to 30 V
Analog output	AO1-GND	Analog output 1	The DIP switch on the control board is used to determine voltage output (default) or current output. Output voltage range: 0 V to 10 V Output current range: 0 mA to 20 mA

Type	Terminal Mark	Terminal Name	Function Description
Digital output	DO1-CME	Digital output 1	Optocoupler isolation; dual-polarity open collector output Output voltage range: 0 V to 24 V Output current range: 0 mA to 50 mA Note that digital output ground CME and digital input ground COM are internally insulated, but are shorted externally by jumper as the factory settings. In this case, DO1 is driven by +24V by default. To drive DO1 by external power supply, remove the jumper between CME and COM.
	FM-COM	High-speed pulse output	The terminal is set by F5-00 (FM terminal output selection). When the terminal is used for high-speed pulse output, the maximum frequency is 100 kHz. When the terminal is used for collector open output, it has the same specifications as DO1.
Relay output	T/A	Common terminal	Driving capacity of the contact: 250 VAC, 3 A, COS Ø = 0.4 30 VDC, 1 A
	T/B	Normally closed (NC) terminal	
	T/C	Normally open (NO) terminal	
Auxiliary interface	J4	Local PG card interface	It is used to connect the resolver, ABZ incremental encoder, 23-bit encoder, and sin-cos encoder.
	J11	External operating panel interface	It is used to connect the external LCD operating panel (SOP-20) or the LED operating panel (MDKE-10).
	J13	Expansion card interface	28-core terminal used to connect to expansion cards, including I/O cards, communication cards, and PG card
	J14	Safety function terminal	For details, see "Table 2-5 STO terminal description" on page 49.
DIP switch	S1 S2 S3		For details, see "Table 2-6 DIP switch descriptions" on page 49.
	S4		Current/Voltage mode selection for AO1 On: Current output mode Off: Voltage output mode

Table 2-5 STO terminal description

No.	Terminal Mark	Terminal Name	Performance Requirement
1	STO1	STO channel 1	Internal: STO1 and STO2 are connected to +24V by jumpers by default. External: You can connect STO1 and STO2 to the COM terminal. For detailed wiring methods, see the STO function.
2	STO2	STO channel 2	
3	+24V	STO channel 1 and STO channel 2 power supply+	
4	COM	Power supply ground of STO channel 1 and STO channel 2	

Table 2-6 DIP switch descriptions

DIP Switch Status			Description
S1	S2	S3	
OFF	OFF	OFF	Voltage mode with the range of 0 VDC to 10 VDC for AI2
ON	OFF	OFF	Temperature mode for AI2 Set the temperature sensor type through F9-75. 0: No temperature sensor (AI used for analog input) 1: PT100 temperature detection input signal, -25°C to 200°C, accuracy: $\pm 8^{\circ}\text{C}$ 2: PT1000 temperature detection input signal, -25°C to 200°C, accuracy: $\pm 8^{\circ}\text{C}$ 3: KTY84-130 temperature detection input signal, -40°C to 260°C, accuracy: $\pm 15^{\circ}\text{C}$ 4: PTC130 temperature detection input signal, -20°C to 180°C, accuracy: $\pm 15^{\circ}\text{C}$
OFF	ON	OFF	Current mode for AI2; current range: 0 mA to 20 mA; input impedance: 500 Ω
OFF	ON	ON	Current mode for AI2; current range: 0 mA to 40 mA; input impedance: 250 Ω

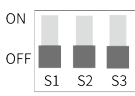
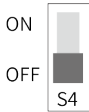
Note

- [Note 1]: If the ambient temperature exceeds 23°C, the output current must be derated by 1.8 mA for every additional 1°C. The maximum output current is 170 mA at 40°C. When OP and +24V are shorted, the maximum output current is calculated by the following formula: 170 mA minus current over the DI.
 - [Note 2]: Based on the maximum output voltage of the signal source, select impedance of 500 Ω or 250 Ω . For example, if 500 Ω is selected, the maximum output voltage cannot be lower than 10 V so that AI2 can measure 20 mA current.
 - S1, S2, and S3 are DIP switches used together for the AI. S4 is the DIP switch for the AO.
-

3 Commissioning Flowchart

3.1 LED Operating Panel

Dimension

The following figures show the outline and installation dimensions of the LED operating panel.

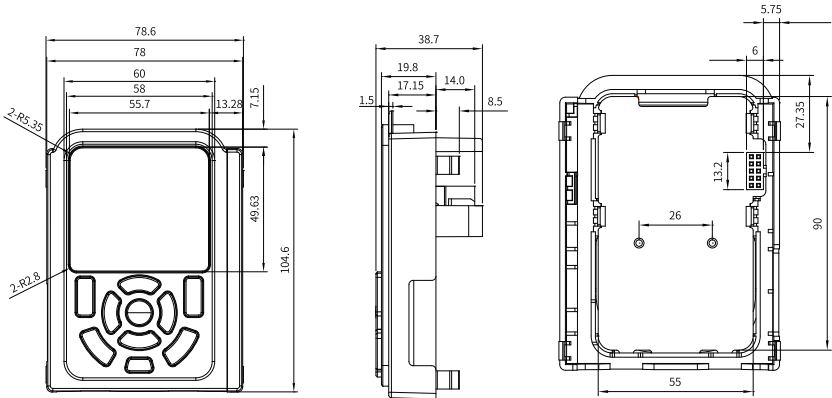

Figure 3-1 Outline and installation dimensions of LED operating panel for T1 to T4 models
(mm)

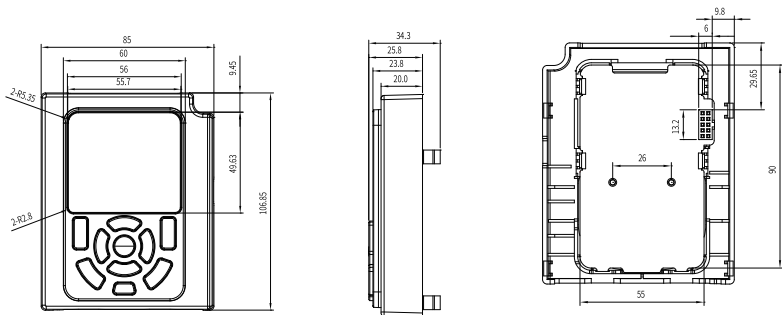

Figure 3-2 Outline and installation dimensions of LED operating panel for T5 to T12 models
(mm)

Components

The LED operating panel can be used to view the operating status and fault information, set parameters, and so on. The following figure shows the operating panel.

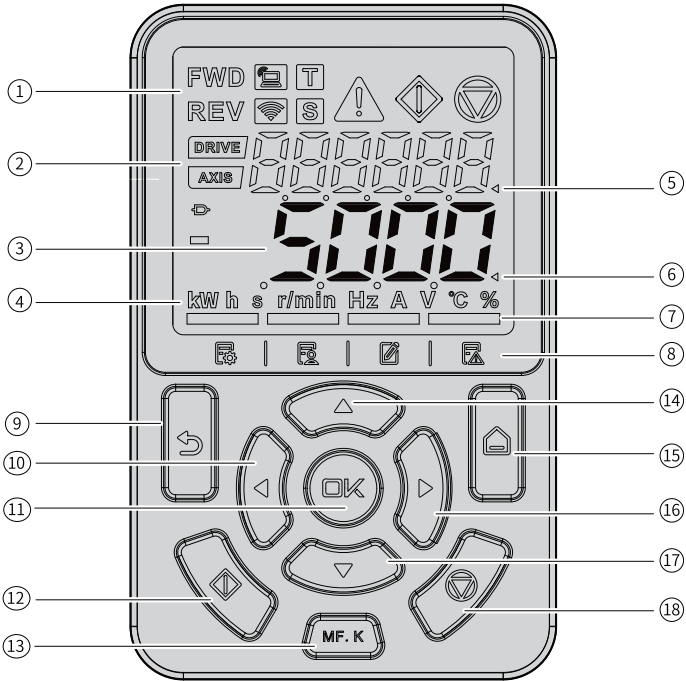

Figure 3-3 Components



Table 3-1 Description of the operating panel





No.	Name	Description
①	Status indicators	/
②	Secondary display area	It displays the following information: <ul style="list-style-type: none"> • Information on key test and motor parameter auto-tuning • Fault and system status monitoring • Station number, motoring status, and STO status.
③	Primary display area	It displays parameter information.
④	Unit indicators	/
⑤	Cursor in the secondary display area	/
⑥	Cursor in the primary display area	/
⑦	Menu indicator	It indicates the current menu and can be switched via the menu key. Only one indicator can become on simultaneously.

No.	Name	Description
⑧	Menu identification	From left to right, the icons indicate the basic menu, user-defined parameter, modified parameter (with default values changed), and fault list.
⑨	Program/Back key	/
⑩	Left shift key	/
⑪	OK key	/
⑫	RUN key	/
⑬	Multi-function key	/
⑭	UP key	/
⑮	Menu key	/
⑯	Right shift key	/
⑰	DOWN key	/
⑱	Stop key	/

Key Descriptions

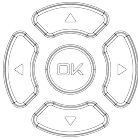

Table 3-2 Key descriptions









Key	Name	Function
	Menu key	Long press the key to switch between the primary display area and the secondary display area. In the primary display area, press the key to switch among different menus, including the basic menu, user-defined parameter, modified parameter (with default values changed), and fault list.
	Program/Back key	Return to the previous interface; Enter level 1 menu
	OK key	Press the key to enter the settings interface or confirm settings.

Key	Name	Function
	Navigation key	In the secondary display area, press the right or left navigation key to switch the display status. Primary display area: <ul style="list-style-type: none"> Basic menu, user menu, and calibration menu: On the monitoring interface, the down key is used as the potentiometer and the left and right keys are used to switch between monitored variables. On the parameter interface, the up and down keys are used to adjust the setpoint, the left and right keys are used to select the bit to set, and the OK key is used to confirm the setpoint. Fault history menu: Press the left or right key to switch the fault history records.
	Multi-function key	You can allocate different functions, such as command source switch, forward run and reverse run switch, or jog to this key.
	RUNkey	In the operating panel control mode, press the key to operate the drive.
	Stop/Fault reset key	When the drive is running, press the key to stop the drive. When the drive is in the faulty state, press the key to perform a reset operation.

Status Indicator

Table 3-3 Status indicator

Status indicator	Status	
	FWD indicator steady on	Forward run/Positive direction
	REV indicator steady on	Reverse run/Negative direction
	FWD/REV indicator blinking	The AC drive is switching between forward running and reverse running.
	Local/Remote indicator off	Local control
	Local/Remote indicator on	Terminal control
	Local/Remote indicator blinking slowly	Communication control
	Local/Remote indicator blinking quickly	User-defined control mode

Status indicator		Status
	Torque control indicator steady on	Torque control
	Speed control indicator steady on	Speed control
	Fault indicator steady on	Fault occurred
	Fault indicator off	No fault
	RUN indicator steady on	Running
	Stop indicator steady on	Stop
	Station number indicator steady on	The station number is displayed in the auxiliary display area.
	Station number indicator off	The value displayed in the auxiliary display area is not the station number.
	AXIS indicator steady on	The axis number is displayed in the auxiliary display area.
	AXIS indicator off	The value display in the auxiliary display area is not the axis number.
	Connector indicator steady on	The connector variable is displayed in the main display area.
	Connector indicator off	The variable displayed in the main display area is not the connector variable.
	Minus sign indicator steady on	The value displayed in the main display area is negative.
	Minus sign indicator off	The value displayed in the primary display area is positive.







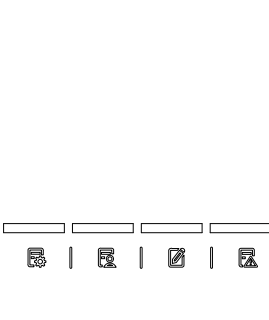

Status indicator		Status
	Cursor indicator in the primary display area steady on	The operating area is the primary display area.
	Cursor indicator in the secondary display area steady on	The operating area is the secondary display area.
kWh s r/min Hz A V °C %	Unit indicator steady on	The unit corresponding to the data displayed in the main display area is the unit with the indicator on. <i>"Table 3-4 " on page 56</i>
	  Indicator steady on	The primary display area displays the basic menu.
	  Indicator steady on	The primary display area displays the user-defined parameter menu.
	  Indicator steady on	The primary display area displays the modified parameter (with the default value changed) menu.
	  Indicator steady on	The primary display area displays the fault menu.

Table 3-4 Unit description

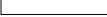
Unit	Description
kW	Power unit
h	Time unit
kWh	Energy unit
s	Time unit
rpm	Rotational speed unit
Hz	Frequency unit
A	Current unit
V	Voltage unit
°C	Temperature unit
%	Percentage

Data Display

The operating panel provides two data display areas: the 6-digit LED secondary display area and the 5-digit LED primary display area.

The auxiliary display area displays the station No., axis No., current state, warning/fault, etc.

The primary display area displays the frequency reference, output frequency, and various monitoring data.

Table 3-5 LED display and actual data

LED Display	Actual Data	LED Display	Actual Data	LED Display	Actual Data	LED Display	Actual Data
0	0	9	9	h	h	r	r
1	1	A	A	c	c	t	t
2	2	B	B	J	J	U	U
3	3	C	C	L	L	y	y
4	4	D	D	n	n	T	T
5	5	E	E	N	N	u	u
6	6	F	F	o	o	/	/
7	7	H	H	P	P	/	/
8	8	G	G	q	q	/	/

3.2 Basic Commissioning Flowchart

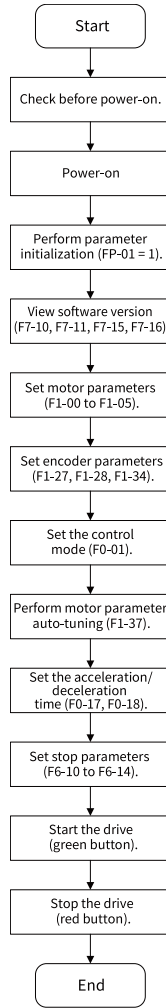

Figure 3-4 Basic commissioning flowchart

Table 3-6 Basic commissioning flowchart

No.	Step	Related Parameter
1	Check before power-on	/
2	Power-on	/
3	Parameter initialization	FP-01
4	View the software version.	F7-10, F7-11, F7-15, F7-16

No.	Step	Related Parameter
5	Set motor parameters.	F1-00 to F1-05 Note that you must set the motor type.
6	Set encoder parameters.	F1-27, F1-28, F1-34
7	Set the control mode.	F0-01
8	Perform motor parameter auto-tuning.	F1-37
9	Set the command source.	F0-02
10	Select the frequency source.	F0-03
11	Set the acceleration and deceleration time.	F0-17, F0-18
12	Set the stop parameters.	F6-10 to F6-14
13	Start	/
14	Stop	/

3.3 Commissioning Flowchart in V/f Control Mode

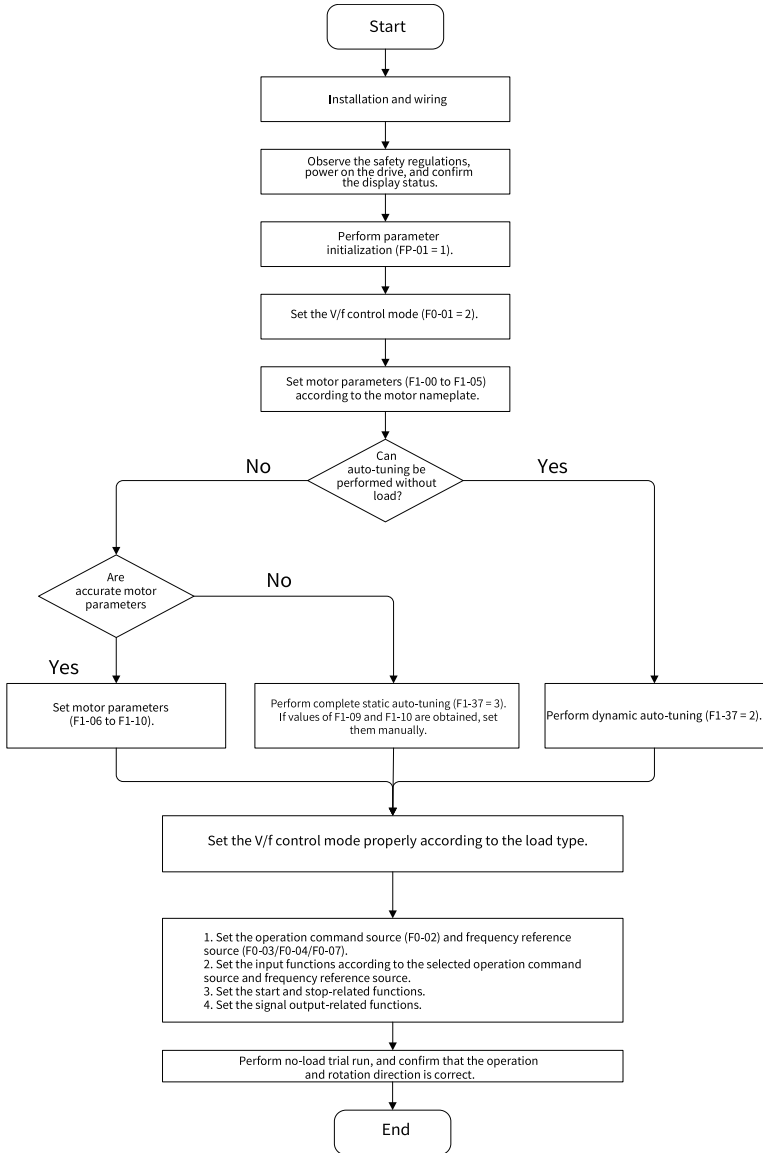

Figure 3-5 Commissioning flowchart in V/f control mode

Note

In the static auto-tuning mode, some parameters are not tuned. For details, see *Asynchronous Motor Parameter Auto-tuning* and *Synchronous Motor Parameter Auto-tuning* sections.

3.4 Commissioning Flowchart in SVC Mode

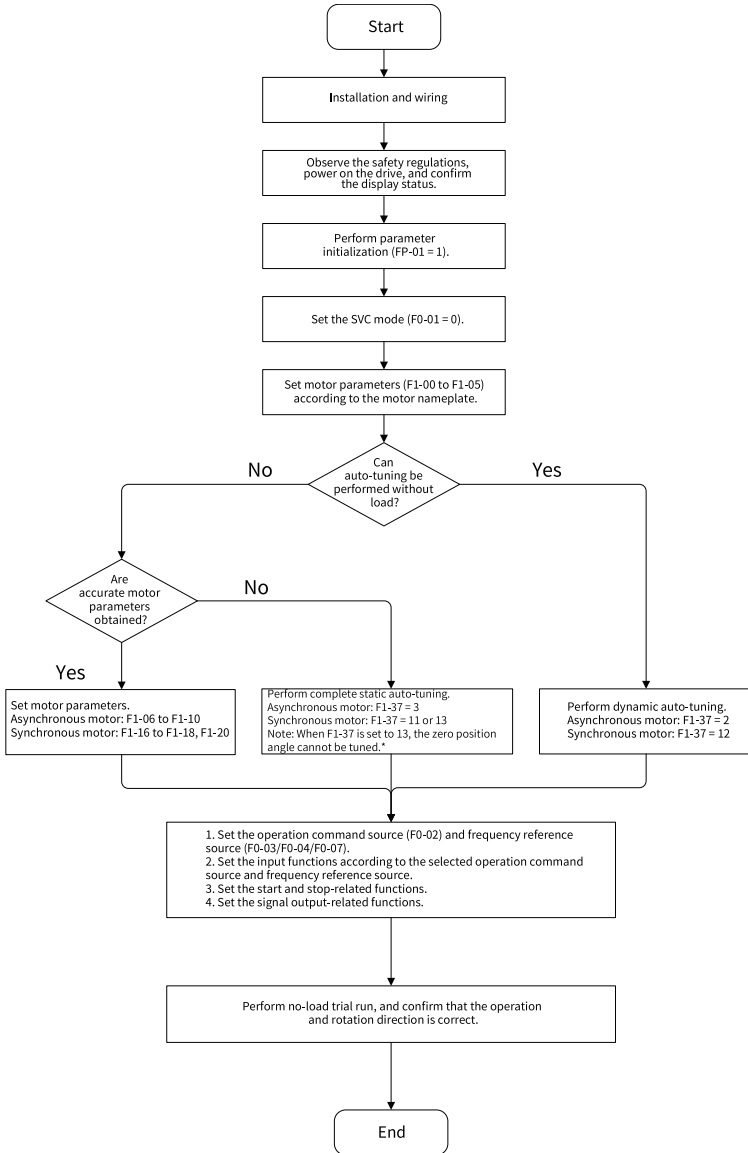

Figure 3-6 Commissioning flowchart in SVC mode

Note

* If bit 0 of A9-09 is enabled and F1-37 is set to 11, the encoder zero position angle will be tuned, but the encoder rotation direction will be not tuned. If F1-37 is set to 13, the encoder will not be tuned. If bit 0 of A9-09 is enabled and F1-37 is set to 11 or 13, the encoder will not be tuned.

During static auto-tuning, the motor will rotate slowly to a certain position when the encoder zero position angle is tuned.

In the static auto-tuning mode, some parameters are not tuned. For details, see *Asynchronous Motor Parameter Auto-tuning* and *Synchronous Motor Parameter Auto-tuning* sections.

3.5 Commissioning Flowchart in FVC Mode

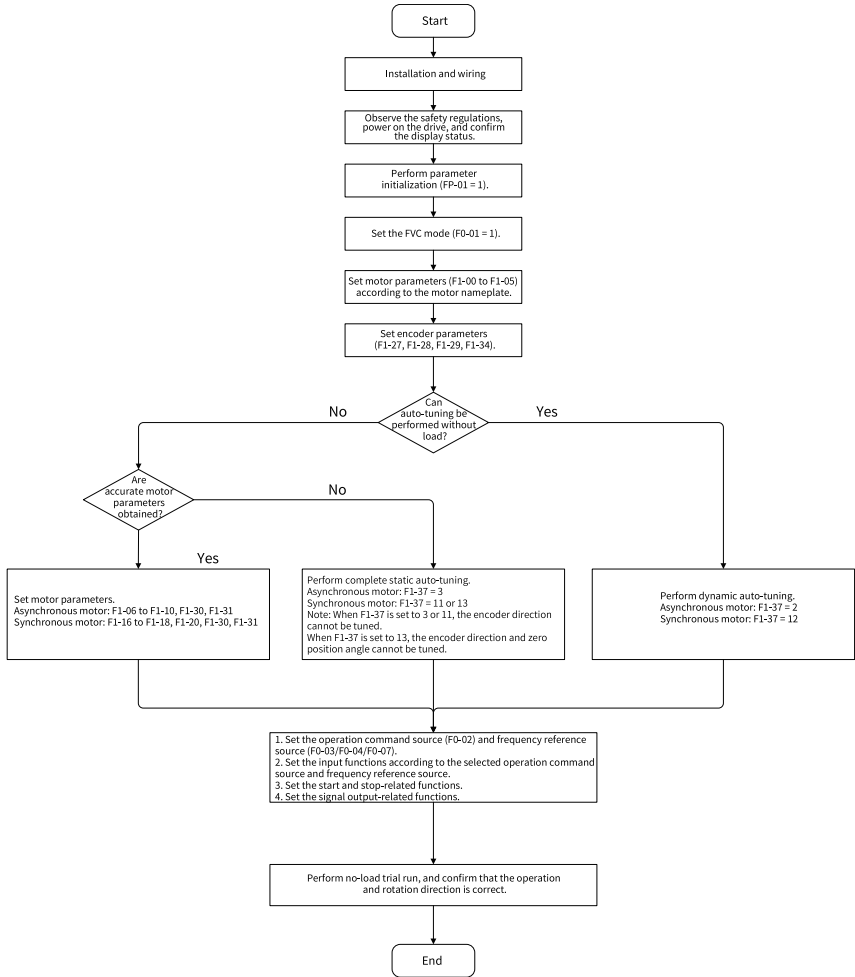

Figure 3-7 Commissioning flowchart in FVC mode

Note

Note:

1. During static auto-tuning, the motor will rotate slowly to a certain position when the encoder zero position angle is tuned.
2. Before static auto-tuning is performed (F1-37 = 11) to tune the zero position angle, check the encoder running direction (F1-30) and set it correctly. At the same time, the motor will rotate slightly static auto-tuning 11 rotates the motor slightly when the encoder zero position angle is tuned.

Encoder direction:The incorrect encoder direction can affect the precise control of the motor by the AC drive. For example, an incorrect direction may cause motor stall. The AC drive will report overload, overcurrent, overheat, and excessive speed deviation faults, which affects the safety and reliability of the system.

Zero position angle:The zero position angle of the motor indicates the position angle of the motor when the magnetic pole is aligned between the stator and the rotor. The following faults will occur when the zero position angle is incorrect:

1. **Positioning error:**An error will occur between the actual position of the motor and the set position. In this case, the position control system cannot locate the position accurately, affecting the operating accuracy of the equipment.
2. **Unstable motion:**Inaccurate zero point angle will cause unsuitability or vibration when the motor executes motion commands, affecting the stability and reliability of the system.
3. **Path deviation:**In applications requiring precise path control (such as manipulators and CNC machines), inaccurate zero position angle may cause path deviation, affecting the quality of processing or operation.
4. **Invalid system protection:**Some systems may rely on the zero position angle to set the safety boundary or limit position. If the zero position angle is not accurate, the system protection mechanism may fail, increasing the risk of mechanical collision or damage.

In the static auto-tuning mode, some parameters are not tuned. For details, see *Asynchronous Motor Parameter Auto-tuning* and *Synchronous Motor Parameter Auto-tuning* sections.

4 Troubleshooting

4.1 Common Faults and Diagnosis

4.1.1 Alarm and Fault Display

Upon exceptions, the AC drive stops output immediately, the fault indicator blinks, and the contact of the fault relay acts. The operating panel of the AC drive displays a fault code (example: **E002.1**), as shown in the following figure.

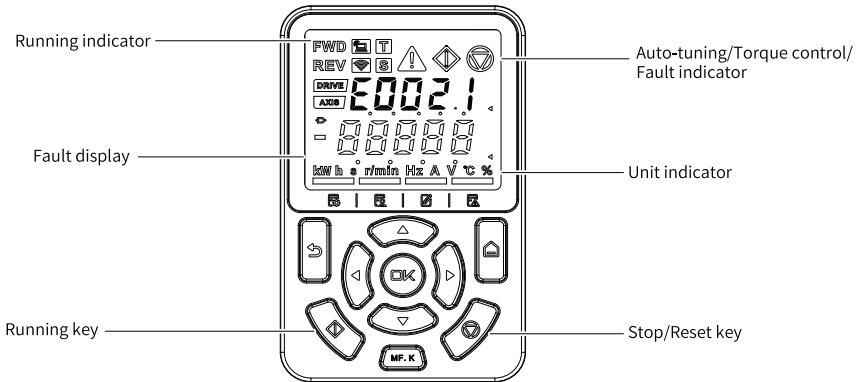

Figure 4-1 Display of faults



Do not repair or modify the AC drive by yourself. In case of any fault that cannot be rectified, contact the agent or Inovance for technical support.

4.1.2 Restart After Fault Occurrence

View the current fault code, fault subcode, fault information, minor fault code, minor fault subcode, minor fault information, warning code, warning subcode, warning information through the operating panel.

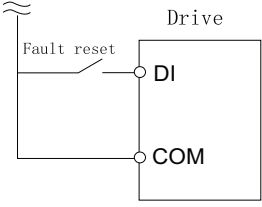
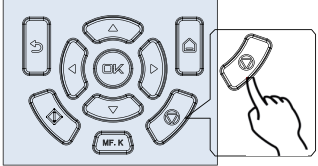
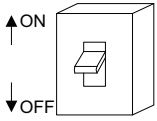
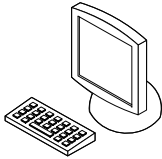
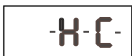

Table 4–1 Fault view and start method after fault occurrence

Stage	Solution	Description
Upon fault	Fault record 1: View the current fault code, fault subcode, fault information, minor fault code, minor fault subcode, minor fault information, warning code, warning subcode, warning information through the operating panel.	View the record through H0-00 to H0-53.
	Fault record 2: View the frequency, current, bus voltage, input terminal status, output terminal status, AC drive status, power-on time, running time, status word A, status word B, and command word of the last three faults through the operating panel.	View the record through F9-14 and F9-44.
	Fault record 3: View the fault code, fault subcode, fault information, frequency, current, bus voltage, input terminal status, output terminal status, AC drive status, power-on time, running time, status word A, status word B, and command word of the last six faults through the operating panel.	View the record through parameters in groups H3 to H8.
Before fault reset	Before fault reset, find the fault cause and remove the fault according to the fault type displayed on the operating panel.	-

Stage	Solution	Description
<p>Reset mode to clear faults</p>	<p>1. Allocate function 9 (fault reset) to the DI by setting any of F4-00 to F4-09 to 9.</p>	
	<p>2. Check that F7-02 is set to 1 (default value), indicating that the STOP/RES key is available in any operating mode.</p>	<p>Press the STOP/RES key on the operating panel.</p> 
	<p>3. Power off and then power on the AC drive for automatic reset. Disconnect the main circuit power supply. Wait until the fault code disappears, and then connect the power supply again.</p>	
	<p>4. Reset the drive through communication. When F0-02 (Command source) is set to 2 (Communication control), write "7" (Fault reset) to communication address 2000H using the host controller to reset the AC drive after the fault is cleared.</p>	

4.1.3 Common Troubleshooting

Table 4-2 Common faults and solutions

No.	Symptom	Possible Cause	Solution
1	There is no display upon power-on. 	The drive is not connected to the grid or the grid voltage is too low.	Check the power supply.
		The switched-mode power supply (SMPS) on the driver board of the AC drive is faulty.	Check whether the 24 V output voltage and 10 V output voltage on the control board are normal.
		The control board is disconnected from the driver board and operating panel.	Disconnect the main circuit from the power supply, and then re-connect the 8-pin and 40-pin flat cables.
		The pre-charge resistor of the AC drive is damaged.	Contact the agent or Inovance for technical support.
		The control board or the operating panel is faulty.	
The rectifier bridge is damaged.			
2	"-H-C" is displayed after power-on. 	The cable connecting the driver board and the control board is in poor contact.	Re-connect the 8-pin and 28-pin flat cables.
		Related components on the control board are damaged.	Contact the agent or Inovance for technical support.
		The motor or the motor cable is short circuited to the ground.	
		The Hall sensor is faulty.	
		The mains voltage is too low.	
3	"E023.1" is displayed upon power-on. 	The motor or the motor cable is short circuited to ground.	Check the insulation status of the motor and the output cable with a megger.
		The AC drive is damaged.	Contact the agent or Inovance for technical support.

No.	Symptom	Possible Cause	Solution
4	The display is normal upon power-on. However, after the drive starts to run, "-H-C-" is displayed and the drive stops immediately.	The fan is damaged or does not rotate.	Replace the fan.
		The cable of the external control terminal is short circuited.	Eliminate external short circuit.
5	E014.1 (module overtemperature) is reported frequently.	The carrier frequency is set too high.	Reduce the carrier frequency (F0-15).
		The cooling fan is damaged, or the air duct is blocked.	Replace the cooling fan or clean the air duct.
		Devices (thermistor or other devices) inside the AC drive are damaged.	Contact the agent or Inovance for technical support.
6	The motor does not rotate when the AC drive is running.	The wiring between the AC drive and the motor is abnormal.	Check that the wiring between the AC drive and the motor is correct.
		Motor parameters of the AC drive are set incorrectly.	Restore parameters to default settings and reset related parameters.
			Ensure encoder parameters and motor rated parameters are set properly, such as rated frequency and rated speed of the motor.
			Check that F0-01 (control mode) and F0-02 (operation mode) are set properly.
		Modify F3-01 (Torque boost) in the V/f control mode during start with heavy load.	
		The cable connecting the driver board and the control board is in poor contact.	Re-connect the cable to ensure it is connected securely.
		The driver board is faulty.	Contact the agent or Inovance for technical support.



No.	Symptom	Possible Cause	Solution
7	DI inactive	The related parameters are set incorrectly.	Check and set the parameters in group F4 again.
		The external signal is incorrect.	Re-connect the external signal cable.
		The jumper between OP and +24V becomes loose.	Secure the jumper between OP and +24V.
		The control board is faulty.	Contact the agent or Inovance for technical support.
8	The motor speed cannot be increased in the FVC mode.	The encoder is faulty.	Replace the encoder disk and double check the cable connection.
		The encoder cable is connected improperly or in poor contact.	Reconnect the encoder to ensure good contact.
		The PG card is faulty.	Replace the PG card.
		The driver board is faulty.	Contact the agent or Inovance for technical support.
9	Frequent overcurrent and overvoltage faults	Motor parameters are set incorrectly.	Set the motor parameters again or perform motor parameter auto-tuning.
		The acceleration/ deceleration time is improper.	Set proper acceleration/ deceleration time.
		The load fluctuates.	Contact the agent or Inovance for technical support.
10	"E017.1" is detected upon power-on or running.	The soft startup contactor is not closed.	Check whether the contactor cable is loose.
			Check whether the contactor is faulty.
			Check whether 24 V power supply of the contactor is faulty.
			Contact the agent or Inovance for technical support.
11	The motor coasts to stop or the brake fails during deceleration or decelerating-to-stop.	The encoder is disconnected, or overvoltage stall suppression protection is enabled.	If the AC drive is in the FVC mode (F0-01 = 1), check the encoder cable connection.
			If a braking resistor is configured, disable the overvoltage stall suppression protection function by setting F3-23 to 0.

4.1.4 Troubleshooting During Trial Run in Different Control Modes

- SVC mode (F0-01= 0; default: 0)
 In this mode, the drive controls the motor speed and torque in a scenario without an encoder for speed feedback. Auto-tuning on motor parameters is required to obtain the motor parameters.

Table 4-3 Troubleshooting in SVC mode

Problem	Solution
Overload or overcurrent during motor start	Set motor parameters F1-01 to F1-05 according to the motor nameplate. Perform auto-tuning (F1-37) on motor parameters. If possible, select dynamic complete auto-tuning.
Slow torque/speed response and motor oscillation occur at a frequency below 5 Hz.	Increase the value of F2-00 (Speed loop proportional gain) by the step value of 10 or decrease the value of F2-01 (Speed loop integral time) by the step value of 0.05 to improve the torque/speed response. If oscillation occurs, decrease the value of F2-00 and increase the value of F2-01.
Slow torque/speed response and motor oscillation occur at a frequency above 5 Hz.	Increase the value of F2-03 (Speed loop proportional gain) by the step value of 10 or decrease the value of F2-04 (Speed loop integral time) by the step value of 0.05 to improve the torque/speed response. If oscillation occurs, decrease the value of F2-03 and increase the value of F2-04.
Low speed accuracy	If the speed deviation is too large when the motor runs with load, increase the value of F2-06 (Vector control slip compensation gain) by the step value of 10%.
Obvious speed fluctuation	Increase the value of A9-05 (Speed filter time) by the step value of 0.001s when motor speed fluctuates abnormally.
Loud motor noise	Increase the value of F0-15 (Carrier frequency) by the step value of 1.0 kHz. Note that increasing the carrier frequency will lead to an increase in the motor leakage current.
Insufficient motor torque or force	Check whether the torque upper limit is too low. If yes, increase the value of F2-10 (Torque upper limit in speed control mode) in the speed control mode or the value of the torque reference in the torque control mode.

- FVC mode (F0-01 = 1)
 This mode is applicable to scenarios with an encoder for speed feedback. In this mode, you need to set the encoder pulses per revolution, encoder type, and encoder direction correctly and perform auto-tuning on motor parameters.

Table 4–4 Troubleshooting in FVC mode

Problem	Solution
Overload or overcurrent fault during start	Set the encoder pulses per revolution, encoder type, and encoder direction correctly.
Overload or overcurrent is detected during motor running.	Set motor parameters F1-01 to F1-05 according to the motor nameplate. Perform auto-tuning (F1-37) on motor parameters. If possible, select dynamic complete auto-tuning.
Slow torque/speed response and motor oscillation occur at a frequency below 5 Hz.	Increase the value of F2-00 (Speed loop proportional gain) by the step value of 10 or decrease the value of F2-01 (Speed loop integral time) by the step value of 0.05 to improve the torque/speed response. If oscillation occurs, decrease the value of F2-00 and F2-01.
Slow torque/speed response and motor oscillation occur at a frequency above 5 Hz.	Increase the value of F2-03 (Speed loop proportional gain) by the step value of 10 or decrease the value of F2-04 (Speed loop integral time) by the step value of 0.05 to improve the torque/speed response. If oscillation occurs, decrease the value of F2-03 and F2-04.
Obvious speed fluctuation	Increase the value of F2-07 (Speed filter time) by the step value of 0.001s when motor speed fluctuates abnormally.
Loud motor noise	Increase the value of F0-15 (Carrier frequency) by the step value of 1.0 kHz. Note that increasing the carrier frequency will lead to an increase in the motor leakage current.
Insufficient motor torque or force	Check whether the torque upper limit is too low. If yes, increase the value of F2-10 (Torque upper limit in speed control mode) in the speed control mode or the value of the torque reference in the torque control mode.

- V/f control mode (F0-01 = 2)

This mode applies to applications without an encoder for speed feedback. You only need to set the rated motor voltage and rated motor frequency correctly.

Table 4–5 Troubleshooting in V/f control mode

Problem	Solution
Motor oscillation during operation	Decrease the value of F3-11 (Oscillation suppression gain in V/f mode) by the step value of 5. The minimum value is 5.
Overcurrent at startup with high power	Decrease the value of F3-01 (Torque boost) by the step value of 0.5%.
Excessively high current during operation	Set F1-02 (Rated motor voltage) and F1-04 (Rated motor frequency) correctly. Decrease the value of F3-01 (Torque boost) by the step value of 0.5%.
Loud motor noise	Increase the value of F0-15 (Carrier frequency) by the step value of 1.0 kHz. Note that increasing the carrier frequency will lead to an increase in the motor leakage current.

Problem	Solution
Overvoltage during deceleration or when heavy load is suddenly removed	Set F3-23 (Overvoltage stall suppression) to 1 (Enable). Increase the value of F3-24/F3-25 (Frequency gain/Voltage gain for overvoltage stall suppression, 30 by default) by the step value of 10 gradually. The permissible maximum value is 100. Decrease the value of F3-22 (Overvoltage stall suppression action voltage, default: 770 V) by the step value of 10 V. The permissible minimum value is 700 V.
Overcurrent during acceleration or when heavy load is suddenly added	Increase the value of F3-20 (Overcurrent stall suppression gain, default: 20) by the step value of 10. The permissible maximum value is 100. Decrease the value of F3-18 (Overcurrent stall suppression action current, default: 150%) by the step value of 10%. The permissible minimum value is 50%.

4.2 List of Faults and Alarms

For complete information on fault and alarm codes, see *MD520 Series General-Purpose AC Drive Parameter Guide*.



19011712B01

Copyright © Shenzhen Inovance Technology Co., Ltd.

Importa y distribuye en Argentina:

ECFA

ECFA S.R.L.

 Av. San Juan 4063 (C1233ABK) - Buenos Aires - Argentina

 +54 11 4923-6566

 ventas@ecfa.com.ar

 <https://www.ecfa.com.ar>

Shenzhen Inovance Technology Co., Ltd.

www.inovance.com

Suzhou Inovance Technology Co., Ltd.

www.inovance.com

Add.: Inovance Headquarters Tower, High-tech Industrial Park,
Guanlan Street, Longhua New District,
Shenzhen 518000, P.R. China

Tel: (0755) 2979 9595

Fax: (0755) 2961 9897

Add.: No.52, Tian'e Dang Road, Wuzhong District,
Suzhou 215104, P.R. China

Tel: (0512) 6637 6666

Fax: (0512) 6285 6720